

# ham radio magazine

## Variable Power Splitting with Multisplit

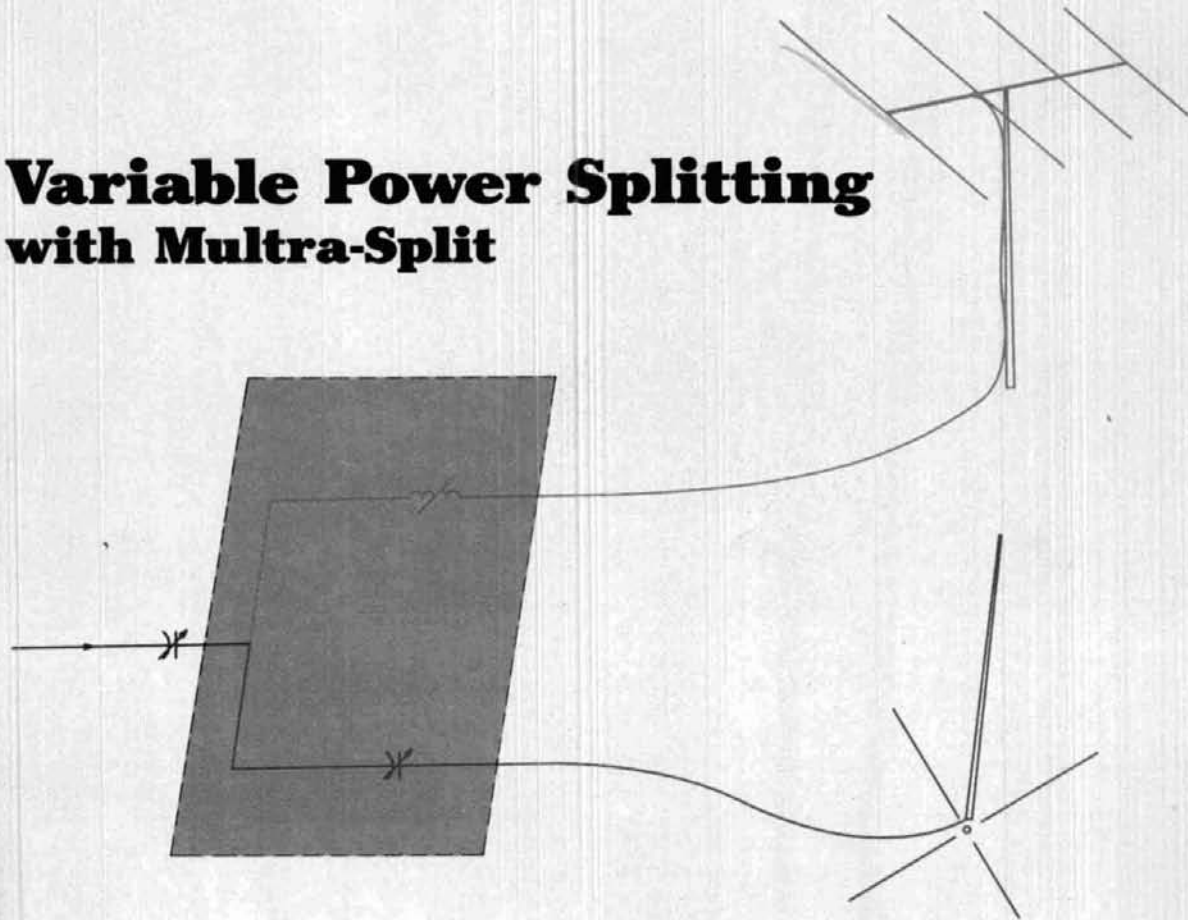

**hr**  
focus  
on  
communications  
technology

*cylindrical feedhorns • two-tone signal generator • the offset drooper: an improved ground plane • improving audio on the ICOM IC-27 • EME link calculator program • quartz crystal resonators • plus W9JUV, W1JR, W6SAI, W6MGI, K4IPV, K0RYW*

ICOM HF Transceiver

# IC-751



## The Standard of Excellence in HF Base Stations

The IC-751 is the most advanced transceiver available today. It's a competition grade ham receiver, a 100KHz to 30MHz continuous tuning general coverage receiver AND a full-featured all mode solid-state ham band transmitter. The IC-751 also covers the new WARC bands, MARS frequencies, and is AMTOR compatible.

**Important Standard Features.** Compare these important standard features in this "top of the line" base station:

- 100KHz - 30MHz Receiver
- 105dB dynamic range
- QSK — full break-in CW (nominal speed 20WPM)

- FM Mode Standard
- High-grade FL-44A 455KHz SSB filter
- 32 tunable Memories with lithium battery backup
- 100% Duty Cycle Transmitter
- Passband Tuning
- 12V DC operation
- Adjustable AGC
- Adjustable Noise Blanker
- RIT/XIT with separate readout
- IC-HM12 Microphone with Up/Down Scan
- Continuously adjustable transmit power

**Options.** IC-EX310 speech synthesizer, internal IC-PS35 power supply, external IC-PS15 or IC-PS30 system supply, IC-SM8 two-cable desk mic,

IC-SM6 desk mic, RC-10 external controller, and a variety of filters.

### FILTER SPECIFICATIONS

Filter	Model	Center Freq. (KHz)	-6dB (KHz) Width
<b>STANDARD FILTERS</b>			
AM Ceramic	CFW 455 IT	455	6.0
SSB (PBT) XTAL	FL-30	9011.5	2.3
FM Filter	9M15A	9011.5	15 (-3dB)
SSB Narrow (Hygrade Crystal)	FL-44A	455	2.4
<b>OPTIONAL FILTERS</b>			
CW Narrow	FL-52A	455	0.500
CW Narrow	FL-53A	455	0.250
SSB Wide	FL-70	9011.5	2.8
CW Narrow	FL-32	9010.6	0.500
CW Narrow	FL-63	9010.6	0.250
AM	FL-33	9010.0	6.0

Operating From 12V, the IC-751 is also available with an optional internal AC power supply, the IC-PS35...for the winning edge in field day competition.



Shown with IC-PS35

The IC-751 provides superior performance for all amateur radio operators...from novice to extra class. See the IC-751 at your local ICOM dealer.

Now with a ONE YEAR Warranty!

First in Communications

ICOM America, Inc., 2380-116th Ave NE, Bellevue, WA 98004 / 3331 Towerwood Drive, Suite 307, Dallas, TX 75231

All stated specifications are approximate and subject to change without notice or obligation. All ICOM radios significantly exceed FCC regulations limiting spurious emissions. 75138

# TOO GOOD TO BE TRUE?

## PAKRATT™ Model PK-64

shown with enhanced  
HFM-64 option installed



★ MORSE ★ BAUDOT ★ ASCII ★ AMTOR ★ PACKET ★

### FIRST FIVE MODE DATA CONTROLLER

The Pakratt model PK-64 by AEA is the world's first computer interface that offers Morse, Baudot, ASCII, AMTOR and Packet all in one box (hardware and software included) at a price many competitors charge for Packet alone (from \$219.95 Amateur net). Do not let the low price fool you; coming from any other company but AEA it WOULD be too good to be true. The PK-64 works with virtually any voice transceiver. The Pakratt is the easiest of any to hook up and have operating in just a few minutes.

In Packet mode, the PK-64 offers virtually all the features of every other Packet controller on the market, plus many important features left out by others due to cost constraints. For example, we have included a hardware HDLC, true Data Carrier Detect (DCD), multiple connect with up to ten stations simultaneously and full implementation of version 2.0 of the AX.25 protocol.

Because the PK-64 was designed specifically for the Commodore 64 (or C-128 and SX-64) computer, we have been able to do many things not economically feasible with general RS-232 interface controllers. For ex-

ample, the Pakratt includes true split screen operation with on-screen status indicators and an on-screen tuning indicator.

### ENHANCED HFM-64 MODEM OPTION

The standard PK-64 will operate all modes with a phase-lock-loop (PLL) detector roughly equivalent to all popular packet modems in the marketplace (except we have included extra filtering). The enhanced HFM-64 modem option offers true independent dual channel filtering with A.M. detection (like the famous CP-100 Computer Patch™). The enhanced HFM-64 option also offers a hardware LED tuning indicator (like the CP-100) and a front panel variable threshold control for setting maximum sensitivity under various band conditions. We recommend the HFM-64 option for anyone keenly interested in weak-signal heavy-QRM HF operation. For anyone desiring to operate FM RTTY with the standard North American tone pair or CW receive, the HFM-64 is required. The HFM-64 is field installable with no soldering or test equipment required.

### WORKS WITH THE POPULAR C-64 COMPUTER

AEA designed the PK-64 around the

low-cost C-64 because of the special architecture features making it especially suited to Amateur Radio applications. The C-64 should not be viewed as a mainframe, but rather a very economical accessory to your data communications system. Many owners of expensive computers such as IBM, TANDY, APPLE, KAYPRO, ATARI, etc., are now buying the low cost C-64 and dedicating it to their operating position. They simply cannot find software for their machine that even approaches the power and user friendliness of the PK-64. Plus, think of the convenience of having only one controller and keyboard to go from one mode to another without having to re-do cabling!

The PK-64 is so complete that all you need to do is wire up a microphone connector to the end of a cable (provided) and you are ready to go. There is no need to track down special terminal software, cabling or even a power supply. It all comes with the PK-64. So do not be the last on your block to own the most exciting new product in years. See the PK-64 at your favorite dealer or write for our specification sheet now.

*Prices And Specifications Subject To  
Change Without Notice Or Obligation*

**Advanced Electronic Applications, Inc.**  
P.O. Box C-2160, Lynnwood, WA 98036-0918  
(206) 775-7373 Telex 6972496 AEA INTL UW

**AEA** Brings you the  
Breakthrough!



# KENWOOD

...pacesetter in Amateur radio

**NEW!**  
Computer Interface!

## “DX-cellence!”

### TS-940S

The new TS-940S is a serious radio for the serious operator. Superb interference reduction circuits and high dynamic range receiver combine with superior transmitter design to give you no-nonsense, no compromise performance that gets your signals through! The exclusive multi-function LCD sub display graphically illustrates VBT, SSB slope, and other features.

- **100% duty cycle transmitter.** Super efficient cooling system using special air ducting works with the internal heavy-duty power supply to allow continuous transmission at full power output for periods exceeding one hour.
- **High stability, dual digital VFOs.** An optical encoder and the flywheel VFO knob give the TS-940S a positive tuning “feel”.
- **Graphic display of operating features.**

Exclusive multi-function LCD sub-

display panel shows CW VBT, SSB slope tuning, as well as frequency, time, and AT-940 antenna tuner status.

- **Low distortion transmitter.** Kenwood’s unique transmitter design delivers top “quality Kenwood” sound.
  - **Keyboard entry frequency selection.** Operating frequencies may be directly entered into the TS-940S without using the VFO knob.
  - **QRM-fighting features.** Remove “rotten QRM” with the SSB slope tuning, CW VBT, notch filter, AF tune, and CW pitch controls.
  - **Built-in FM, plus SSB, CW, AM, FSK.**
  - **Semi or full break-in (QSK) CW.**
  - **40 memory channels.** Mode and frequency may be stored in 4 groups of 10 channels each.
  - **Programmable scanning.**
  - **General coverage receiver.** Tunes from 150 kHz to 30 MHz.
  - **1 yr. limited warranty.** Another Kenwood First!
- Optional accessories:**
- AT-940 full range (160-10m) automatic antenna tuner
  - SP-940 external

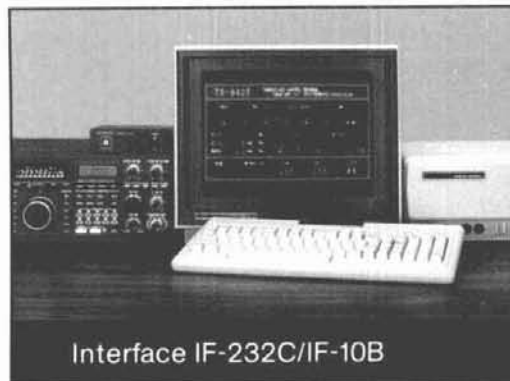

Interface IF-232C/IF-10B

speaker with audio filtering • YG-455C-1 (500 Hz), YG-455CN-1 (250 Hz), YK-88C-1 (500 Hz) CW filters; YK-88A-1 (6 kHz) AM filter • VS-1 voice synthesizer • SO-1 temperature compensated crystal oscillator • MC-42S UP/DOWN hand mic. • MC-60A, MC-80, MC-85 deluxe base station mics. • PC-1A phone patch • TL-922A linear amplifier • SM-220 station monitor • BS-8 pan display • SW-200A and SW-2000 SWR and power meters.

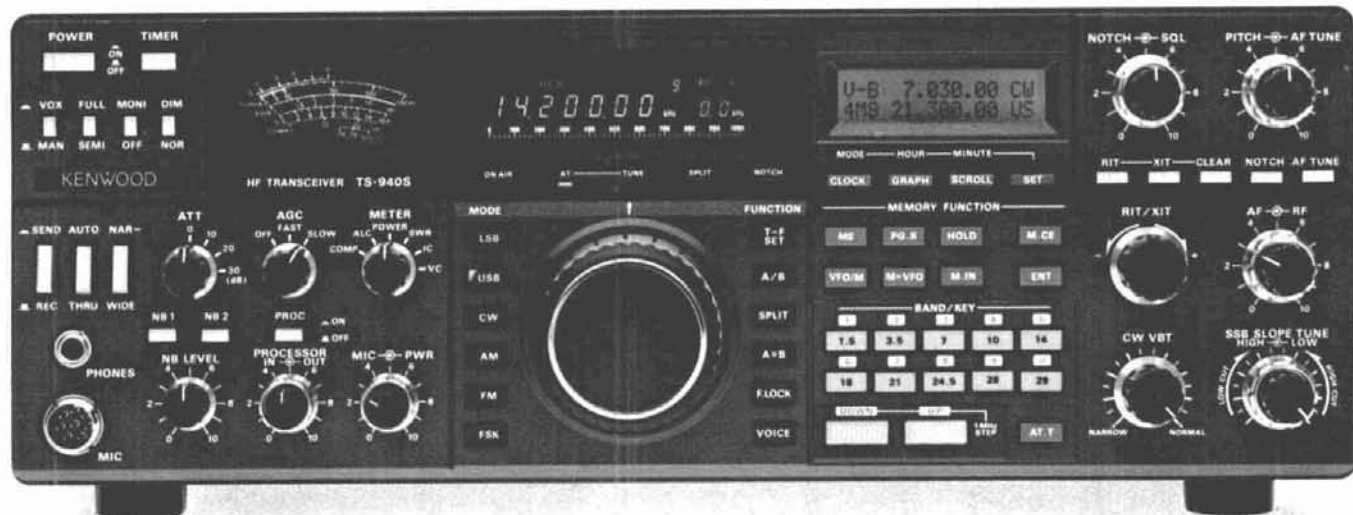

Complete service manuals are available for all Tri-Kenwood transceivers and most accessories. Specifications and prices are subject to change without notice or obligation.



More TS-940S information is available from authorized Kenwood dealers.

## KENWOOD

TRIO-KENWOOD COMMUNICATIONS  
1111 West Walnut Street  
Compton, California 90220



# ham radio

magazine

**FEBRUARY 1986**

**volume 19, number 2**

**T. H. Tenney, Jr., W1NLB**  
publisher

**Rich Rosen, K2RR**  
editor-in-chief  
and associate publisher

**Dorothy Rosa, KA1LBO**  
assistant editor

Joseph J. Schroeder, W9JUV  
Alfred Wilson, W6NIF  
associate editors  
Susan Shorrock  
editorial production

#### editorial review board

Peter Bertini, K1ZJH  
Forrest Gehrke, K2BT  
Michael Gruchalla, P.E.  
Bob Lewis, W2EBS  
Mason Logan, K4MT  
Ed Wetherhold, W3NQN

#### publishing staff

**J. Craig Clark, Jr., N1ACH**  
assistant publisher

**Rally Dennis, KA1JWF**  
director of advertising sales

Dorothy Sargent, KA1ZK  
advertising production manager

Susan Shorrock  
circulation manager  
Therese Bourgault  
circulation

ham radio magazine is published monthly by  
Communications Technology, Inc.  
Greenville, New Hampshire 03048 0498  
Telephone: 603 878 1441

#### subscription rates

United States:  
one year, \$22.95; two years, \$38.95; three years, \$49.95  
Canada and other countries (via surface mail):  
one year, \$31.00; two years, \$55.00; three years, \$74.00  
Europe, Japan, Africa (via Air Forwarding Service): one year, \$37.00  
All subscription orders payable in U.S. funds, via international  
postal money order or check drawn on U.S. bank

international subscription agents: page 106

Microfilm copies are available from  
University Microfilms, International  
Ann Arbor, Michigan 48106  
Order publication number 3076

Cassette tapes of selected articles from ham radio  
are available to the blind and physically handicapped  
from Recorded Periodicals,  
919 Walnut Street, Philadelphia, Pennsylvania 19107

Copyright 1986 by Communications Technology, Inc.  
Title registered at U.S. Patent Office

Second-class postage paid  
at Greenville, New Hampshire 03048 0498  
and at additional mailing offices  
ISSN 0148 5989

Send change of address to ham radio  
Greenville, New Hampshire 03048 0498



## contents

### 10 achieve polarization diversity through variable power splitting

John H. Mullaney, W3NGJ

### 20 cylindrical feedhorns revisited

Norman J. Foot, WA9HUV

### 25 two-tone signal generator

Bill McLagan, YB9ATA/WA7AQN

### 35 practically speaking

Joe Carr, K4IPV

### 43 the offset drooper: an improved ground plane

Woodrow Smith, W6BCX

### 51 VHF/UHF world

Joe Reisert, W1JR

### 61 improving the audio on the ICOM IC-27

Edward Richley, KD8KZ

### 65 ham radio techniques

Bill Orr, W6SAI

### 70 EME link calculator program

David Engle, KE6ZE

### 85 quartz crystal resonators

Peter Boddaert

### 109 the Guerri report

Ernie Guerri, W6MGI

110 advertisers index and reader service 104 ham mart  
99 new products

9 comments 6 presstop  
78 DX forecaster 4 reflections  
106 flea market

# REFLECTIONS

## a wrong-headed solution for someone else's problem

Anyone who carries on a telephone conversation should have a reasonable expectation that the conversation will be private. That's a concept with which it's difficult to quarrel. After all, like motherhood, apple pie, and the Stars and Stripes, privacy is something that the American citizen takes for granted. For those who'd challenge the right to electronic privacy there are severe penalties against wiretapping and (in the Communications Act of 1934) against the misuse or divulgence of any private communication heard over the airwaves.

However, in the view of the few who are utilizing a relatively small portion of the radio frequency spectrum for a very lucrative business — cellular telephone — that's not good enough. After all the time, money, and technical genius they've invested in developing cellular technology, they've suddenly discovered it's possible for others to eavesdrop on what their customers are saying!

So have they harnessed some of their technical genius to solve this terrible problem? Of course not. They've gone to the place where any and all problems are solved easily and at someone else's expense: Washington, D.C.

And what's the solution that Washington has devised? Very simple. Under the terms of bills presently moving through the U.S. House and Senate, the citizens of the United States will no longer have any fundamental right of access to the radio frequency spectrum. As those bills are written, it will become a crime to listen to any radio frequency unless the government specifically decides the frequency is one to which it will permit the general public to listen.

Bizarre? Of course. Absurd? Certainly, but that's precisely the premise of the "Electronic Communications Privacy Act of 1985." To be sure, the Act will include some exemptions, with the first being, as a matter of course, for "broadcasting." From then on, however, the exemptions will get a bit stickier; the Act's avowed purpose is to "prevent" the casual listener, no matter how innocent his intent, from "intercepting" any radio transmission that is not intended for his ears.

The only exemptions to this blanket closing off of the spectrum to casual listening will be those services specifically excluded at their own request or due to the beneficence of the bill's authors. Since WWV's time signals will probably qualify as "broadcasting," you should be able to continue setting your watch with them, but if your receiver draws a bit off 10.000 MHz and you end up using a nearby unidentified CW signal for code practice, you're going to need a good lawyer if you get caught.

"But Amateur Radio will be one of the exempt services," you may object, "so what's our problem?" That's just it. It isn't *our* problem — it's everybody's problem. Have you ever tuned below the broadcast band to ship-to-shore CW around 500 kHz, to aircraft radio ranges, to the "Lowfers" with their 1-watt rigs on 1750 meters, or to the various odd signals below 100 kHz? Forget it. It's going to be illegal. Have you ever tuned between the international broadcast bands to see what else goes on in the HF spectrum? Forget it. Illegal. Like to hear what's happening at the local airport tower, on marine VHF FM, or the various caboose-to-engine railroad frequencies? Forget it. Illegal!

Of course, some of these frequencies might not be illegal; they might just be included in that hallowed list of exemptions. But do you really want some Congressional staffer in Washington to sit down with a large yellow pad and decide for you each and every frequency he'll let you tune to and which will be forbidden, from DC to light? That's the way the bills are written, and that's the way they're expected to work.

Wrong-headed? This proposal certainly is, because it establishes a position that's precisely 180 degrees contrary to the position firmly established for the American people in the earliest days of radio. That position has, from the very beginning, been that the radio frequency spectrum is a public resource, and with only the very minimum regulation necessary, the right of public access to that spectrum should not be denied.

This right really dates from just after World War I, when the U.S. Navy tried to maintain complete control of the airwaves it had been given when the United States entered the war. When the war began, Amateurs were not only off the air, but also required to take down antennas and dismantle receivers. Within weeks after the war's end, a bill was introduced in Congress to continue Navy control of all radio communications in peacetime, but due in part to Amateur opposition, the bill failed. Nonetheless, it wasn't until April, 1919, that the Navy lifted its ban on Amateur receiving. However, the Navy still wouldn't give up its attempt to retain control of all radio until that September, when a Congressional resolution finally forced it to turn radio regulation back to the Department of Commerce, and Amateurs once again regained the right to transmit.

Though in subsequent years the amount of Amateur spectrum has varied from time to time, the right of Amateur Radio to exist — and for the public to listen to whatever it pleased — was never again seriously challenged . . . at least until now. This isn't because the consequences of unlimited public access to the RF spectrum were not understood; these consequences were addressed in the Communications Act of 1934, which made it unlawful to misuse or divulge information derived from listening to private radio communications. In 1934, at least, the framers of the law were wise enough to realize they could not stop casual radio listening without placing a "Kilocycle Cop" in every household.

So what's really wrong-headed about these bills is their basic philosophy. First of all, they take the position that "We, the elite, have the absolute right to decide what you, the populace, can and cannot do with a radio receiver." With this "right," they take from all of us — SWLs, Lowfers, scanner buffs, Amateurs, and even the guy with a short wave or "public safety" band on his kitchen radio — the right to tune a receiver where it pleases us . . . a right that's existed since before anyone even knew how to tune a receiver.

Furthermore, this proposed law is completely unenforceable. It will succeed only in making criminals out of millions of otherwise honest citizens, while the tiny minority that eavesdrops for illicit purposes will continue to do so with impunity, just as it does today. All this repressive and futile effort, simply to "solve" a problem for a narrow-minded special-interest group with a need to cover up its own self-induced shortcoming — lack of communications security — at the expense of the American people.

This makes me mad — mad enough to tell my Senators exactly how I feel about S-1667 and my Representatives what I think of HR-3378. I hope it makes you that mad, too.

Joseph Schroeder, W9JUV

# KENWOOD

...pacesetter in Amateur radio

## Handy Handful...

### TR-2600A/3600A

Kenwood's TR-2600A and TR-3600A feature DCS (Digital Code Squelch), a new signalling concept developed by Kenwood. DCS allows each station to have its own "private call" code or to respond to a "group call" or "common call" code. There are 100,000 different DCS combinations possible.



- **Simple to operate**  
Functional design is "user friendly." Built-in 16-key autopatch encoder, TX STOP switch, REVERSE switch, KEYBOARD LOCK switch, high efficiency speaker.
- **Large LCD**  
Easy to read in direct sunlight or in the dark with convenient dial light that also illuminates the top panel S-meter.
- **Extended frequency coverage**  
Allows operation on most MARS and CAP frequencies. Receive frequency range is 140-160 MHz. (TR-3600A covers 440-450 MHz.)
- **Programmable scan**  
Channel scan or band scan, search for open or busy channels.
- **SLIDE-LOC battery case**
- **10 Channels**  
10 memories, one for non-standard repeater offsets.
- **2.5 watts high power, 350 mW low**  
TR-3600A has 1.5 watts high or 300 mW low.

The Kenwood TR-2600A and the TR-3600A pack "big rig" features into the palm of your hand. It's really a "handy handful"!

Optional accessories:

- TU-35B built in programmable sub-tone encoder
- VB-2530 2-m 25 W RF power amp.
- ST-2 base stand/charger
- MS-1 mobile stand/charger
- PB-26 Ni-Cd battery
- DC-26 DC-DC converter
- HMC-1 headset with VOX
- SMC-30 speaker microphone
- LH-3 deluxe leather case
- SC-9 soft case with belt hook
- BT-3 AA manganese/alkaline battery case
- EB-3 external C manganese/alkaline battery case
- RA-3 2-m telescoping antenna
- RA-5 2-m/70-cm telescoping antenna
- AX-2 shoulder strap w/ant. base
- CD-10 call sign display
- BH-2A belt hook

More TR-2600A and TR-3600A information is available from authorized Kenwood dealers.



## KENWOOD

TR-2600A shown. TR-3600A is available for 70 cm operation.  
Complete service manuals are available for all Trio-Kenwood transceivers and most accessories.  
Specifications and prices are subject to change without notice or obligation.

TRIO-KENWOOD COMMUNICATIONS  
1111 West Walnut Street  
Compton, California 90220



THERE IS A THREAT TO AMATEUR RADIO IN THE "COMMUNICATIONS PRIVACY ACT OF 1985" in spite of an assumption by some observers that "exemption" from its provisions is sufficient protection. It could hurt recruitment, since many future Amateurs become interested in Amateur Radio through casual listening of the type the new bill would prohibit. Furthermore, the total government control of the radio spectrum that it imposes would almost certainly be applied to Amateurs in the future. (For additional in-depth discussion of the proposal's far-reaching negative effects, see this month's editorial.)

TWO CONTRADICTORY BAND PLANS FOR THE NEW 33 CM (902-928 MHz) BAND are now in use, following adoption of its own plan by the Southern California Repeater and Remote Base Association (SCRRBA). The SCRRBA plan, adopted at an 11/16 meeting, totally ignores the ARRL's VUAC-developed plan -- despite the League's plan having been developed over a period of several years and having been well advertised, both before and after its adoption early last year. For example, the SCRRBA plan not only incorporates different sub-bands, but different FM channel spacing and repeater offsets! Neither plan accommodates the Japanese 903-905 MHz personal radios, which could provide an initial source of equipment to encourage startup activity on the band.

Further Delays In Occupying The Band Will Result from this conflict, with makers hesitating to develop 33 cm equipment compatible with two conflicting standards. As a result, competition from other services or for other uses for this choice 26-MHz wide band will continue to surface. For example, one petitioner has proposed the FCC permit the use of low-power video links -- for example, VCRs to TV sets -- throughout the band. ARRL has filed strong comments against the proposal, designated RM-5193 by the Commission, on the grounds that such joint use would result in unacceptable mutual interference.

TWO NEW RUSSIAN SATELLITES ARE SCHEDULED TO BE LAUNCHED in the very near future, possibly in early February. The two birds, designated RS-9 and RS-10, are expected to be placed in low earth orbit with approximately 120-minute periods. RS-9 will have a single Mode A (2 meters up, 10 meters down) transponder, but RS-10 promises to be the most technologically sophisticated Russian Amateur space effort yet.

Mode K (15 Meters Up, 10 Meters Down) and Mode I (a never-before-used 15 meters up, 2 meters down) transponders are believed to be included in RS-10, along with the usual Mode A transponder. A 2-meter beacon on 145.557 MHz and another on 70 cm (still pending license agreements) will also be included.

RS-10 Is Reported To Have Successfully Completed Checkout and be ready for launch, but RS-9 has had some problems. If problems are resolved in time, the two birds should be launched together; otherwise, RS-10 could go up alone.

Another ISKRA Satellite Launch, In Connection With Refueling of the Russian Salyut 7 Spacecraft, is also thought to be imminent. If so, a Mode K transponder will be included. Since this is an even lower altitude event, the satellite lifetime could be as short as a month or so and the orbital period no more than about 90 minutes.

A PETITION FOR A 52-54 MHz "PUBLIC DIGITAL RADIO SERVICE" submitted by Don Stoner, W6TNS, has been designated RM-5241 by the FCC. Stoner's proposal would create a highly automated low-power (1-watt maximum) packet computer-to-computer "hobbyist" radio system, using the top half of 6 meters because of its low usage by Amateurs and unsuitability for other purposes due to the TVI potential. He also suggests there'd be no repetition of the CB chaos of 27 MHz in his service, since he proposes no voice communications -- only data. The FCC released its public notice on RM-5241 on 12/6/85, so the closing date for receipt of Comments was 1/6/86.

THE U.S. AMATEUR POPULATION CREPT TO AN ALL-TIME HIGH of 413,642 individual operators as 1985 drew to a close. The breakdown by license class shows Generals most numerous, with 117,082, followed by Advanced (97,781), Tech (83,387), Novice (77,087), and Extra (38,305). California still has more than twice as many Amateurs as any other state (57,151), with New York (25,897), Florida (24,675), and Texas (24,444) in a close race for second.

Biggest Problem Continues To Be The Novice Class, which is the only license class that's failing to grow. At the end of FCC's fiscal 1983 there were 86,781 Novice licenses in force; a year later that had dropped to 80,461. At presstime the Novice ranks had dwindled by almost another 3400 to 77,087. The continued growth of the higher classes demonstrates the VEC program is working well; the failure is in recruiting new blood.

SPREAD SPECTRUM WILL BE AVAILABLE FOR GENERAL AMATEUR USE ABOVE 420 MHz as of June 1, 1986. Though the new mode may be used for essentially any type of Amateur communication, the rules governing its use are extensive and quite detailed. Potential users should refer to Part 97.71 of the Amateur rules, a new section pertaining only to spread spectrum.

73 MAGAZINE HAS BEEN RETURNED TO ITS FOUNDER, WAYNE GREEN, W2NSD, in a surprise move by CW Communications. CW had acquired 73 as part of the package when they bought Green's computer magazines several years ago, and it was well known in the industry that they've been trying to dispose of it for some time. What is surprising is that Green has returned to the helm, since he'd stated on numerous occasions that he believed Amateur Radio is a dying hobby and he no longer had any serious interest in it.

# KENWOOD

...pacesetter in Amateur radio



## TS-130SE HF transceiver

- 80-10 meters including the new 10, 18 and 24 MHz bands. Receives WWV on 10 MHz.
- 200 W PEP/160 W DC input on 80-15 meters. 160 W PEP/140 W DC on 12 and 10 meters.

- Digital display, built-in.
- IF shift circuit.
- Speech Processor, built-in.
- Narrow/wide filter selection on CW and SSB with optional filters.
- Automatic SSB mode selection.
- RF attenuator, built-in.
- Effective noise blanker.
- Final amplifier protection circuit assures maximum

- reliability. Output power is reduced if abnormal operating conditions occur.
- Other features: VOX, CW semi break-in with sidetone, one fixed channel, and 25 kHz marker.

### Optional accessories:

- PS-30 or PS-430 matching power supplies.
- SP-120 external speaker.
- VFO-120 remote VFO.
- YK-88C 500 Hz CW filter.
- YK-88CN 270 Hz CW filter.
- YK-88SN 1.8 kHz narrow SSB filter.
- AT-130 antenna tuner.
- MB-100 mobile mounting bracket.
- MC-30S/MC-35S hand microphones.
- MC-50 desk microphone.



## TS-670 All-mode "Quad Bander"

- Covers 6, 10, 15 and 40 meter bands.
- 10 W output (4 W AM).
- Direct keyboard frequency selection.
- 80 memory channels.
- Programmable scanning.
- IF shift.
- All-mode squelch.

- Noise blanker.
  - Narrow-wide filter selection.
  - RF attenuator.
  - Dual digital VFOs.
- Optional accessories:**
- PS-430 DC power supply.
  - GC-10 general coverage unit, 500 kHz to 30 MHz.
  - VS-1 voice synthesizer.

- FM-430 FM unit.
- YK-88C 500 Hz CW filter.
- YK-88CN 270 Hz CW filter.
- YK-88A 6 kHz AM filter.
- MC-60A deluxe desk microphone.

- MC-80 desk microphone.
- MC-85 multi-function desk microphone.
- VOX-4 VOX unit.
- MB-430 mobile bracket.

# KENWOOD

TRIO-KENWOOD COMMUNICATIONS  
1111 West Walnut Street  
Compton, California 90220

# BEST OF MFJ

## MFJ 24 HOUR LCD CLOCKS

These MFJ 24 hour clocks make your DXing, contesting, logging and SKEDing easier, more precise.

Read both UTC and local time at a glance with the MFJ-108, \$19.95, dual clock that displays 24 and 12 hour time simultaneously. Or choose the MFJ-107, \$9.95 single clock for 24 hour UTC time.

Both are mounted in a brushed aluminum frame, feature huge easy-to-see 5/8 inch LCD numerals and a sloped face that makes reading across-the-shack easy and pleasant.



MFJ-108  
\$19.95

MFJ-107  
\$9.95



MFJ 24 HOUR LCD CLOCK  
MODEL MFJ-107

You can read hour, minute, second, month and day and operate them in an alternating time-date display mode. You can also synchronize them to WWV for split-second timing. Both are quartz controlled for excellent accuracy.

They are battery operated so you don't have to reset them after a power failure, and battery operation makes them suitable for mobile and portable use. Long life battery included. MFJ-108 is 4 1/2 x 1 x 2 in. MFJ-107 is 2 1/4 x 1 x 2 in.

## RTTY/ASCII/AMTOR/CW MFJ-1229 COMPUTER INTERFACE \$179.95



Everything you need is included for sending and receiving RTTY/ASCII/CW on a Commodore 64 or VIC-20 and your ham rig. You get MFJ's most advanced computer interface, software on tape and all cables. Just plug in and operate.

The MFJ-1229 is a general purpose computer interface that will never be obsolete. An internal DIP switch, TTL and RS-232 ports lets you adapt the MFJ-1229 to nearly any home computer and even operate AMTOR with appropriate software.

A crosshair "scope" LED tuning array makes accurate tuning fast, easy and precise.

You can transmit both narrow (170 Hz) and wide (850 Hz) shift while the variable shift tuning lets you copy any shift (100-1000 Hz) and any speed (5-100 wpm, 0-300 baud ASCII).

Automatic threshold correction and sharp multipole active filters give good copy under severe QRM, weak signal and selective fading.

There's an FM (limiting) mode for easy trouble-free tuning that's best for general use and an AM (non-limiting) mode that gives superior performance under weak signals and heavy QRM.

A handy Normal/Reverse switch eliminates retuning while checking for inverted RTTY.

An extra sharp 800 Hz CW filter really separates the signals for excellent copy. 12 1/2 x 12 1/2 x 6 inches. Uses floating 18 VDC or 110 VAC with MFJ-1312, \$9.95.

## MFJ PORTABLE ANTENNA

MFJ's Portable Antenna lets you operate 40, 30, 20, 18, 15, 12, 10 meters from apartments, motels, camp sites, vacation spots, any electrically clear location where space for full size antenna is a problem.

A telescoping whip (extends 54 in.) is mounted on self-standing 5 1/2 x 6 3/4 x 2 1/4 inch Phenolic case. Built-in antenna tuner, field strength meter, 50 foot coax. Complete multi-band portable antenna system that you can use nearly anywhere. 300 watts PEP.

MFJ-162  
\$79.95



## MFJ ANTENNA BRIDGE MFJ-204B \$79.95

Now you can quickly optimize your antenna for peak performance with this portable, totally self-contained antenna bridge that you can take to your antenna site—no other equipment is needed.

You can determine if your antenna is too long or too short, measure its resonant frequency and antenna resistance to 500 ohms. It's the easiest and most convenient way to determine antenna performance available today to anyone. There's nothing else like it and only MFJ has it. Built-in resistance bridge, null meter and tunable oscillator-driver (1.8-30 MHz). Uses 9 V battery. 4 x 2 x 2 inches.

## REMOTE ACTIVE ANTENNA

The authoritative "World Radio TV Handbook" rates the MFJ-1024 as "a first-rate easy-to-operate active antenna ... Quiet, with excellent dynamic range and good gain ... Very low noise factor ... Broad frequency coverage ... the MFJ-1024 is an excellent choice in an active antenna"

54 inch remote active antenna mounts outdoor away from electrical noise for maximum signal and minimum noise pickup. Often outperforms long-wire hundreds of feet long. Mount anywhere—atop houses, buildings, balconies, apartments, ships.

Use with any radio to receive strong clear signals from all over the world. 50 KHz to 30 MHz. High dynamic range eliminates intermodulation. Inside control unit has 20 dB attenuator, gain control.

Switch 2 receivers and auxiliary or active antenna. "On" LED. 6 x 2 x 5 in. 50 ft. coax. 12 VDC or 110 VAC with MFJ-1312, \$9.95.

MFJ-1024  
\$129.95

## 200 WATT VERSA TUNER

MFJ-901B \$59.95

MFJ's smallest 200 watt Versa Tuner matches coax, random wires and balanced lines from 1.8 thru 30 MHz. Works with all solid state and tube rigs. Very popular for use between transceiver and final amplifier. Efficient air-wound inductor gives more watts out. 4:1 balun, 5x2x6 in.



## ROLLER INDUCTOR TUNER



MFJ-989 \$329.95

Meet the Versa-Tuner V™, the compact roller inductor tuner that lets you run up to 3 KW PEP and match everything from 1.8 to 30 MHz.

Designed to match the new smaller rigs, the MFJ-989 is the best roller inductor tuner produced by MFJ. Our roller inductor tuner features a 3-digit turn counter plus a spinner knob for precise inductance control for maximum SWR reduction. Just take a look at all these other great features! Built-in 300 watt, 50 ohm dummy load, built-in 4:1 balun and a built-in lighted meter that reads SWR and forward and reflected power in 2 ranges (200 and 2000 watts). Accuracy ±10% full scale. Meter light requires 12 VDC. 6 position antenna switch. 10 3/4 x 4 1/2 x 15 inches.

## MFJ "DRY" DUMMY LOADS

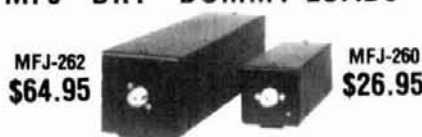

MFJ-262  
\$64.95

MFJ-260  
\$26.95

MFJ's "Dry" dummy loads are air cooled—no messy oil. Just right for tests and fast tune up. Non-inductive 50 ohm resistor in aluminum housing with SO-239. Full load to 30 seconds, de-rating curve to 5 minutes. MFJ-260 (300 watt), SWR 1.1:1 to 30 MHz, 1.5:1, 30-160 MHz, 2 1/2 x 2 1/2 x 7 in. MFJ-262 (1 KW), SWR 1.5:1 to 30 MHz, 3x3x13 inches.

## MFJ ELECTRONIC KEYS



MFJ-407  
\$69.95

MFJ-407 Deluxe Electronic Keyer sends lambda, automatic, semi-auto or manual. Use squeeze, single lever or straight key. Plus/minus keying. 8 to 50 WPM. Speed, weight, tone, volume controls. On/Off, Tune, Semi-auto switches. Speaker. RF proof. 7 x 2 x 6 inches. Uses 9 V battery, 6-9 VDC or 110 VAC with AC adapter, MFJ-1305, \$9.95.

ORDER ANY PRODUCT FROM MFJ AND TRY IT-NO OBLIGATION. IF NOT SATISFIED, RETURN WITHIN 30 DAYS FOR PROMPT REFUND (less shipping).

- One year unconditional guarantee • Made in USA
- Add \$5.00 each shipping/handling • Call or write for free catalog, over 100 products.

# MFJ

MFJ ENTERPRISES, INC.  
Box 494, Mississippi State, MS 39762

TO ORDER OR FOR YOUR NEAREST DEALER, CALL TOLL-FREE

800-647-1800

Call 601-323-5869 in Miss. and outside continental USA Telex 53-4590 MFJ STKV





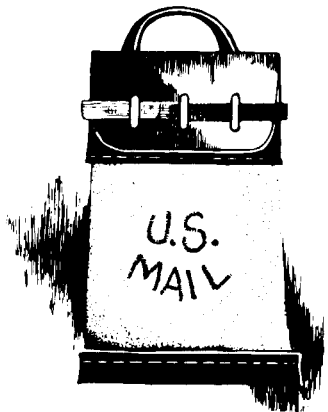

# comments

## odd antennas

Dear HR:

Those of us who have been hams for 30 years but are not radio engineers sometimes wonder about certain unused antenna designs. Perhaps the expertise of the readership of *ham radio* can enlighten us on these peculiar issues.

For instance, every antenna handbook I own describes the advantages in gain of 5/8-wave verticals and 1.28 wave dipoles, the 1.28 wave dipole having a 3-dB gain over a half-wave dipole (see the Extended Double Zepp, fig. 1). Why aren't more antennas designed using the 1.28-wave element, especially at frequencies above 144 MHz?

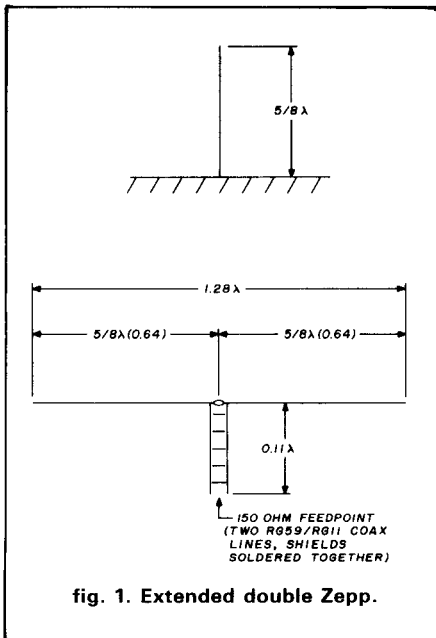

fig. 1. Extended double Zepp.

Every good handbook describes the Windom 14 percent off-center-fed antenna (fig. 2A), normally usable at 1/2, 1, and 2-wave frequencies — three bands. Why aren't multi-band dipoles (fig. 2B) tubular beams (fig. 2C) and quads (fig. 2D) designed for 3-bands per element 14 percent off-center-feed?

And since the Windom 600-ohm feedpoint occurs at 14 percent off-center (or 64 percent from one end) and the high-gain 5/8-wave vertical is a 62.5 percent feed point, why won't a bent-Windom vertical, fed 64 percent up, with a 36 percent horizontal section, produce a near 5/8-wave superior

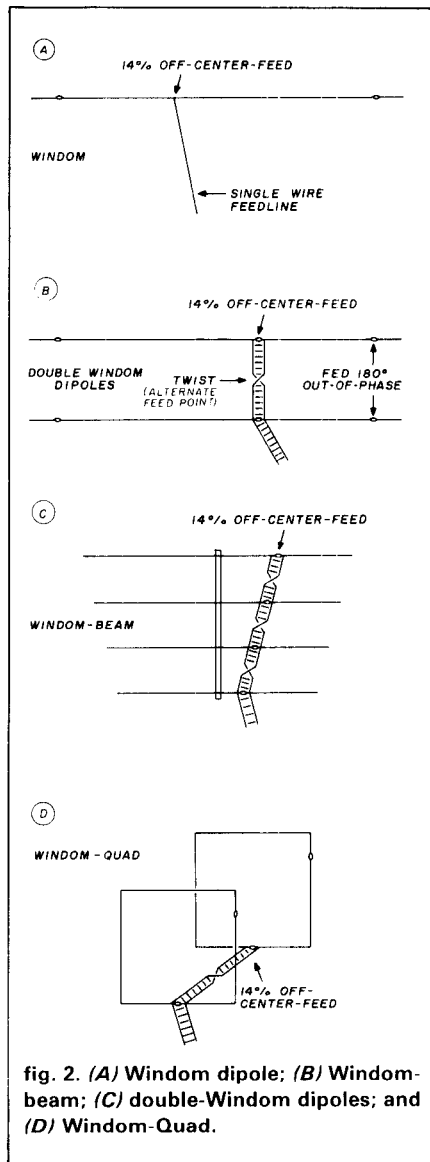

fig. 2. (A) Windom dipole; (B) Windom-beam; (C) double-Windom dipoles; and (D) Windom-Quad.

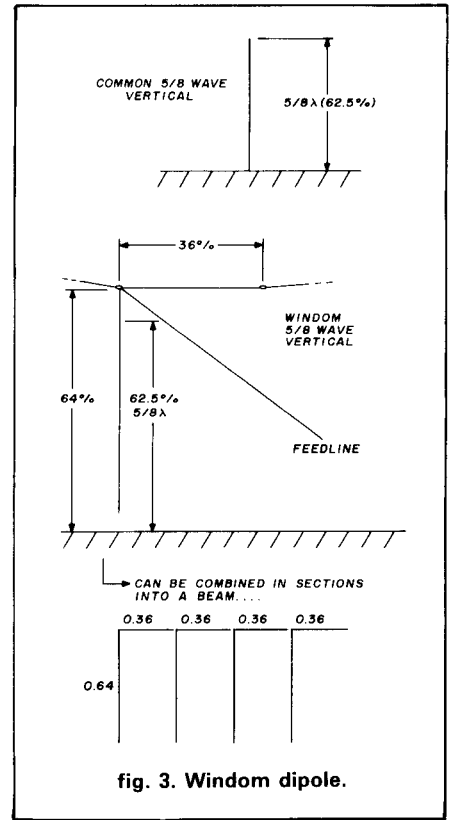

fig. 3. Windom dipole.

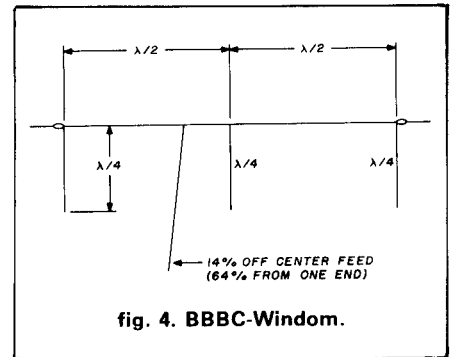

fig. 4. BBBC-Windom.

signal plus a signal on two other bands (fig. 3)?

Since the BBBC (Broadside Bidirectional Bobtail Curtain) (fig. 4) antenna is excellent on one band for DX, why can't it be fed at the 600-ohm off-center Windom feedpoint to make it a multiband antenna?

No doubt there are very good reasons why these antennas do not exist, but a good, logical answer would be gratifying to those of us empirical tinkerers who are theory-deficient.

C.N. Francis, W0MBP  
Silsbee, Texas

# achieve polarization diversity through variable power splitting

Multra-split circuit  
increases signal strength  
and extends  
transmission times

**The reception of high frequency (3-30 MHz) signals** propagated via the ionosphere is characterized at times by irregular and deep fading (indeed, in such places as the auroral zone, by long periods of excessive absorption resulting in communications blackout). This is related to varying amounts of energy in the vertical and horizontal components of the radio wave. A device at the transmitter that takes account of this condition will enhance communications. Power is divided between two transmitting antennas in such a manner that ratios of from 1:1 to 10:1 can be effected without mismatch. In this manner, vertical and horizontal components of the transmission pattern are compensated to prevent fading at the receiving location utilizing radiation angle diversity. A characteristic of the entire propagation phenomenon during altitude changes of the ionosphere is that the horizontal and vertical components never fade simultaneously. Power splitting takes advantage of this characteristic when other parameters of the system have already been optimized. In this way, communications on a particular band may be extended for up to several hours using this technique.

It is generally accepted that an HF antenna with a

low angle of radiation is capable of sustaining usable communications for additional periods as long as two to three hours, during the ionosphere transitional periods.

It is also recognized that during this transitional time some disruption of communications circuits takes place. HF stations normally change their frequencies to re-establish communications. Therefore, any reasonable means that will allow a communicator to extend the transmission period and/or improve the reliability of communications during a transition period, without changing bands, is worth investigating.

During the last 15 years, I have conducted a series of limited experiments on 15 and 20 meters using a transceiver and a pair of antennas. One was a six-element horizontal trap-beam, and the other a vertical antenna. Power from the transmitter was divided between the two antennas by means of a network called *Multra-split*. The *Multra-split* network allowed the power to be divided anywhere from 1:1 to 10:1 without mismatch at the transmitter.

In practice, the antenna with the highest gain is fed the highest power, and generally the higher gain antenna is horizontally polarized. However, depending upon the band of transmission and time of day, it can be more favorable to feed higher power to the vertical antenna.

## sky-wave propagation<sup>1</sup>

At high frequencies, long-distance communication is possible only via sky-wave propagation, whereby radio waves are refracted back to earth from one of the surrounding ionized layers. These layers are the

**By John H. Mullaney, W3NGJ, 9049 Shady Grove Court, Gaithersburg, Maryland 20877.**

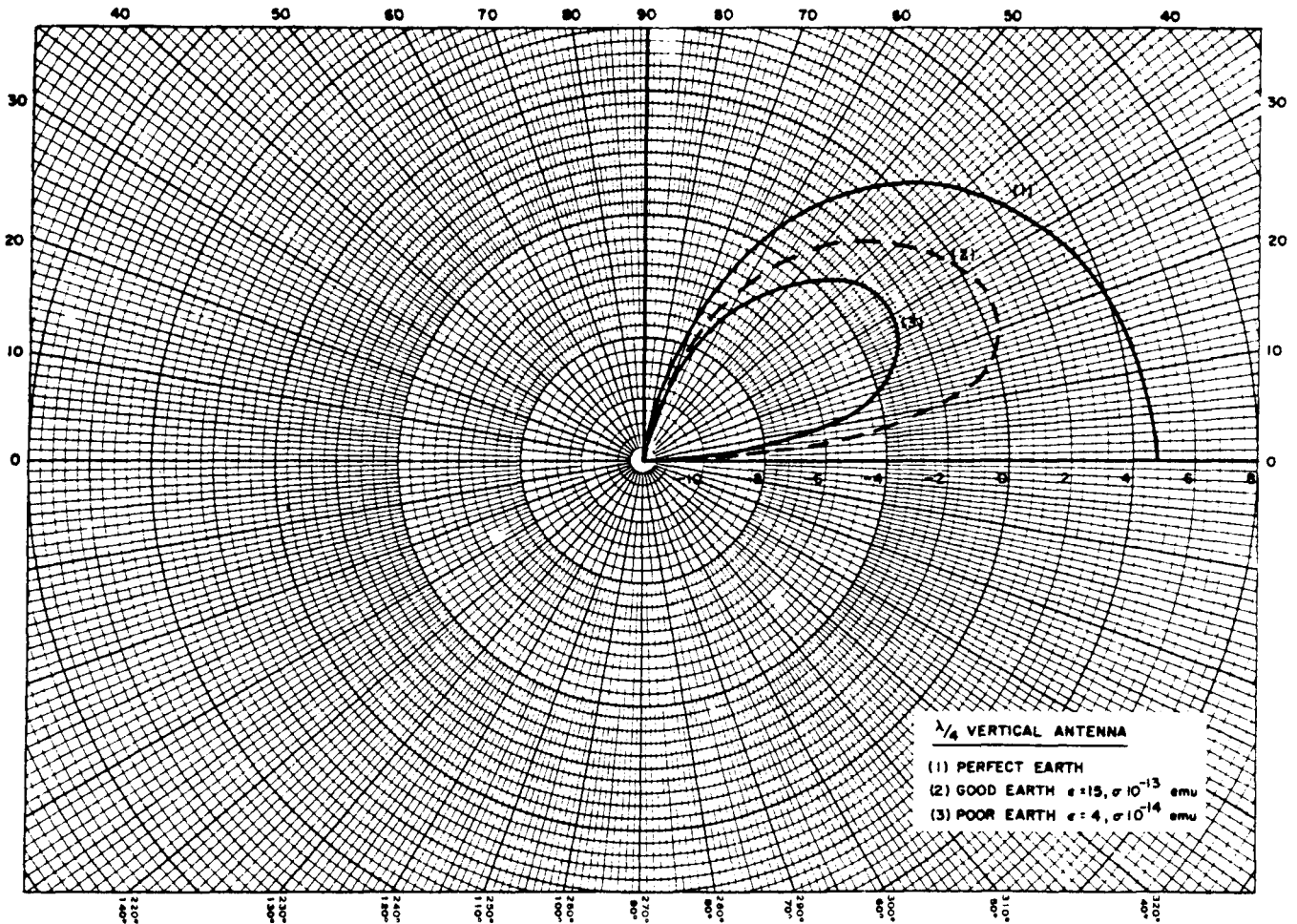

fig. 1. Vertical radiation pattern over earth.

result of ionization of neutral gas in the atmosphere by ultraviolet radiation from the sun.

Because of the variation in the structure of the atmosphere with height and the selective absorption by the various gases of the radiation from the sun, the ionization tends to have several regions of maximum electron density at various heights. These regions are the E-layer, at an average height of 70 miles (113 km), the F1 layer, at about 140 miles (225 km), and the F2 layer, at approximately 250 miles (402 km). Below the E-layer, during the day, is another ionized region at an average height of 35 miles (56 km). This is called the D-region. The D-region accounts for daytime absorption of medium-frequency radio waves. This is the principal reason 80 and 160 are considered night-time bands. These layers, as might be expected (since radiation from the sun is the principal ionizing agent), are present during daylight. At night the D-region is not present, the F1 layer merges with the F2 layer at an average altitude of approximately 175 miles (282 km), and the E-layer essentially disappears.

## polarization

Antennas may be classified as linear elements, apertures, arrays, or traveling wave types. For our discussion, and considering that we are interested in Amateur communications in the 2-30 MHz range, we will deal only with linear and array types.

Two field components are present on an antenna: the magnetic and electric fields. Radio waves, like light waves, can have a definite polarization. Radio wave polarization is determined by the orientation of the electric field component, which in turn is determined by the orientation of the elements themselves.

On a linear antenna or an array of elements, the magnetic field component is always at right angles to the radiator, whereas the electric field component is always in the same plane as the radiator. This means that a vertical antenna or radiator will transmit a vertically polarized wave and a horizontal radiator will transmit a horizontally polarized wave.

Most of the common optical effects experienced



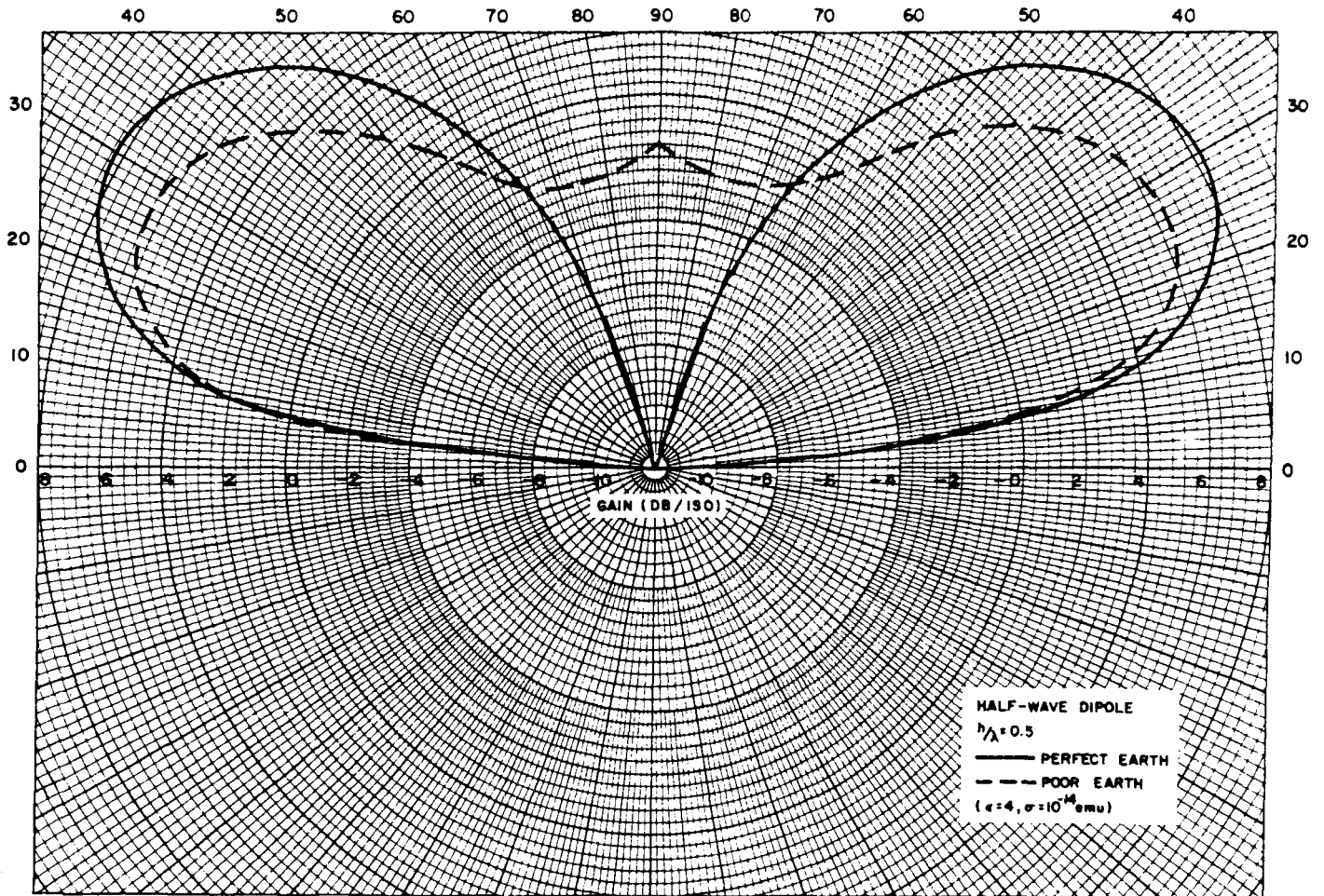

fig. 2. Vertical radiation pattern for horizontal half wave dipole at 180 degrees above earth.

with polarized light also occur between pairs of antennas having different polarizations, when the medium (such as free space) between the antennas does not affect polarization. A linear antenna used for receiving responds most strongly to another antenna with the same polarization, and not at all to one polarized at 90 degrees to the first antenna.

Vertically polarized waves radiated by a vertical antenna over imperfect ground are elliptically polarized because of the presence of a small electric field along the ground in space quadrature and the different time phase from the major electrical component.

For high-frequency ionospheric layer propagation, the received signal is usually elliptically polarized, even when the transmitting antenna produces linear polarization. This condition arises from the effect of the earth's magnetic field on the ionized layers; it splits the incident linearly polarized signal into an ordinary and extraordinary wave. The two waves travel at different velocities and experience different polarization rotations. The resultant received signal is elliptically polarized; consequently, depending on the orien-

tation of the receiving antenna and its height above ground, the received signal may not be usable. The use, therefore, of a vertically and horizontally polarized antenna with a special combining network (such as Multisplit) may provide improved communications not only from a signal strength standpoint, but also over an extended period of time.

The effectiveness of this method of propagation is directly affected by the radiation axis or radiation angle of the antennas used. Whether an antenna is vertically or horizontally excited, its vertical radiation pattern shape is a function of its electrical and physical heights above the ground.

**Figures 1 and 2** show the vertical radiation pattern for a horizontal and vertical antenna.

Note that the vertical shape of the elevation pattern is a function of the earth's conductivity. The lower the conductivity, the more pronounced the distortion to the vertical pattern (high angle signals are hardly attenuated). Either antenna can be selected for the high power side, depending upon transmission path conditions.

# When we set out to make the best amateur radio equipment in the world, we had some pretty tough standards to live up to ...



... yours

... and ours.

So we designed the **RC-850 Repeater Controller**, the industry's top of the line repeater control system. Now in it's "third wave" of innovation, thanks to its designed for the future architecture and new software releases. The '850 defines the industry standard in repeater control systems.

- Fully remotely programmable with Touch-Tone commands
- Front panel LED display
- Over 300 word customized male and female speech synthesis vocabulary
- Time/day of week Scheduler with 10 set-up states, 30 changeovers and events, over 100 scheduled items for hands off operation and automatic reminders.
- Full or half duplex autopatch, autodial (250 numbers), emergency autodial, reverse autopatch, antidiater, toll restrict including telephone exchange tables, supports remote and multiple phone lines
- Informative remotely programmable ID's (17), tail messages (13), bulletin boards (5)
- 16 channel voice response analog metering, automatic storage of min/max values on each channel, values may be read back on command or may be included in any programmable messages
- Supports synthesized remote base transceivers and full duplex links
- Individual user access codes to selectable features
- Mailbox for user-to-user, and system-to-user messages
- Paging—two-tone, 5/6 tone, DTMF, CTCSS, HSC display, user commandable and may be included in programmable messages (i.e. alarms)
- Easy hookup to any repeater

Our new **Digital Voice Recorder** lets you remotely record ID's, tail messages, and various other response messages for automatic playback through your repeater. Audio is stored digitally with no-compromise reproduction quality in up to eight megabits of memory. The DVR can support up to three independent repeaters for a low per-channel cost. Its Touch-Tone activated voice mailbox lets your users easily record messages for other users when they aren't around.

## QST: Attention All Hams

If you own a shack, you should know about ShackMaster™

**ShackMaster** lets you carry your home station with you in the palm of your hand. It acts as your gateway to the world, linking your handheld transceiver to your high performance HF station. Now, instead of your valuable home equipment being available to you 1% of the time, it's available 99% of the time! Whether around the house, in the yard, or across town, ShackMaster lets you take it with you.

But that's just part of ShackMaster's story. It lets you communicate with the family by handling third party traffic – its electronic mailbox and intercom let you keep in touch. And a simplex patch lets you place important calls directly through your home phone.

- Crossband linking – VHF/UHF to HF
- Telephone access to your home station
- BSR Home Control interface
- Electronic Mailbox
- ShackPatch™ intercom into the shack
- PersonalPatch™ simplex autopatch

If your repeater budget can't afford the '850, we offer the **RC-85 Repeater Controller**, which we like to call the "second best repeater controller in the world". It's a scaled down, simplified version of our '850, but overall, it offers more capability and higher quality than anyone else's control equipment at any price.

- Remotely programmable with Touch-Tone commands
- Over 175 word customized male speech synthesis vocabulary
- Selectable "Macro sets" for easy control operator selection
- Autopatch, autodial (200) numbers, emergency autodial, reverse patch
- Remotely programmable informative ID's (7), tail messages (3), bulletin board (2)
- Supports synthesized remote base transceiver, control receiver, alarm
- Selectable, informative courtesy tones
- Talking S-meter, Two-tone paging
- Easy hookup to any repeater

For those who like to "roll their own", we can get you off to a rolling start with our **ITC-32 Intelligent Touch-Tone Control Board**. Much more than just a decoder, it's a mini-control system of its own, with the basic repeater and remote base functions built-in. And it can be tailored by you with its Personality Prom.

- 28 remotely controllable latched or pulsed logic outputs
- 4 alarm or remote sensed logic inputs
- Response messages to confirm command entry
- Repeater functions including COR, IDer, timers, courtesy tone, etc.
- Remote base functions including control of synthesized transceiver

- Remotely recordable, variable length audio tracks, accessed from controller messages
- Top quality, no compromise audio reproduction
- Supports up to three repeaters for cost effective installation
- Expandable to roughly 6 minutes of speech in 8 megabits of memory
- Easy interface to RC-850, RC-85 controllers, or to any stand-alone repeater

All our products are documented with high quality, easy to read manuals. Our goal is to advance the state of the repeater art. But most of all, our products put the FUN back into the FUN MODE!



To order one of these advanced control products, call 408-749-8330. Visa and Mastercard accepted. Technical manuals are available for purchase and the amount paid is applied as a deposit on the equipment. For specifications and a copy of our ACC Notes newsletter, just write or send in your QSL card to:

**acc** advanced computer controls, inc.

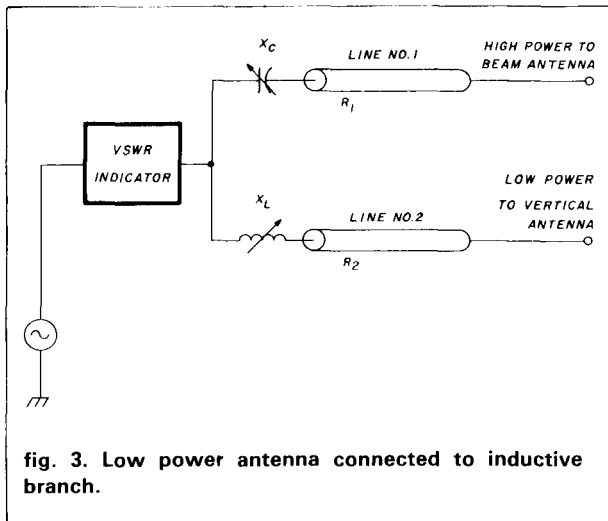

fig. 3. Low power antenna connected to inductive branch.

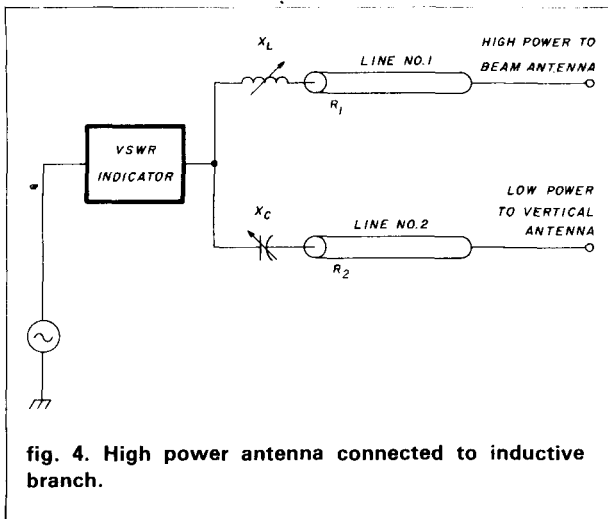

fig. 4. High power antenna connected to inductive branch.

One way to enhance reception and transmission in a varying polarization environment is to use a combiner/power divider network that responds more favorably to the dominant polarization.<sup>2,3</sup> A transmitting type circuit that provides this function (Multisplit) is shown in fig. 3. In this case, two antennas — one horizontally polarized, the other vertically polarized — are fed by a network that splits the power as required. This configuration provides more power to the beam antenna. If the polarization that propagates best is vertical, then the fig. 4 configuration is more appropriate.

### circuit operation

The Multisplit circuit is basically a simple power divider. There are two equal loads (50 or 70 ohms),  $R_1$ , and  $R_2$ , which represent the transmission line resistance for antennas 1 and 2. Reactances  $X_C$  and  $X_L$  are of opposite sign and their values are uniquely determined by the power-division ratio and input

impedance desired. In this case, the input impedance is selected to match the output of the transmitter (50 or 70 ohms). For our discussion, we will assume the use of 50-ohm transmission lines. The power division is determined by the transmission path conditions. Generally, with a high-gain horizontal beam and a vertical whip, the higher power is fed to the beam and just enough power is fed to the vertical antenna to obtain the diversity effect.

The power division can be expressed in terms of a factor  $M'$ , as follows:

$$M' = \frac{P(hi)}{P(low)} \quad (1)$$

where

$P(hi)$  = power to fed to Line 1,

$P(low)$  = power fed to Line 2.

The value of reactance for the high-power leg (Line 1)

is:

$$X = \pm \frac{R_1}{M'} \quad (2)$$

where

$X$  = value of positive or negative reactance in ohms,

$R_1$  = Line 1 resistance in ohms,

$M'$  = power-division factor defined above.

The value of the reactance for the low-power side (Line 2)

is:

$$X = \pm M' \cdot R_2 \quad (3)$$

where

$X$  = value of positive or negative reactance in ohms,

$M'$  = power-division factor,

$R_2$  = line 2 resistance in ohms (must be equal to Line 1 resistance).

It will be demonstrated later that the input impedance will always be equal to the transmission-line impedances, provided certain design requirements are met. This is the same as saying that, under the required conditions, the feedpoint resistance will always remain equal to the load resistance, regardless of the power division between the two branches.

### practical application

Assume a station desired to divide its power on a 90/10 basis; that is, 90 percent in line 1 and 10 percent in line 2. The known parameters are:

$f$  (frequency) = 14.250 MHz.

$P$  (transmitter output) = 500 watts.

$R$  (transmitter output impedance) = 50 ohms.

$I$  (transmitter output current for 500 watts)



$$I = \sqrt{\frac{P}{R}} = \sqrt{\frac{500}{50}} = 3.16 \text{ amperes.} \quad (4)$$

Current in line 1 for 450 watts:

$$I = \sqrt{\frac{450}{50}} = 3.0 \text{ amperes} \quad (5)$$

Current in line 2 for 50 watts:

$$I = \sqrt{\frac{50}{50}} = 1.0 \text{ amperes} \quad (6)$$

Power division factor:

$$M' = \sqrt{\frac{P (hi)}{P (low)}} = \sqrt{\frac{450}{50}} = 3 \quad (7)$$

An inductor is selected arbitrarily for the high power branch. The reactance is:

$$X_L = + \frac{RI}{M'} = \frac{50}{3} = 16.7 \text{ ohms.} \quad (8)$$

Because we selected an inductor for the high power side, a capacitor must be used in the low power branch. Its reactance is:

$$X_C = M' \cdot RI = 3 \times 50 = 150 \text{ ohms.} \quad (9)$$

and since it's a capacitive reactance = -150 ohms. The magnitude of  $X_L$  and  $X_C$  have now been determined. The inductance and capacitance can be readily found. The inductance is:

$$L = \frac{0.159X_L}{f} \quad (10)$$

where

- L = inductance in microhenries
- $X_L$  = inductive reactance in ohms,
- f = frequency in MHz.

solving for L

$$L = \frac{0.159 \cdot 16.7}{14.25} = 0.186 \mu H \quad (11)$$

The capacitance is determined by:

$$C = \frac{159 \times 10^3}{f \times X_C} \quad (12)$$

where

- C = capacitance in picofarads,
- $X_C$  = capacitive reactance in ohms,
- f = frequency in MHz.

Then:

$$C = \frac{159 \times 10^3}{14.25 \times 150} = 74.39 \text{ pF.} \quad (13)$$

The circuit can now be redrawn as in fig. 5.

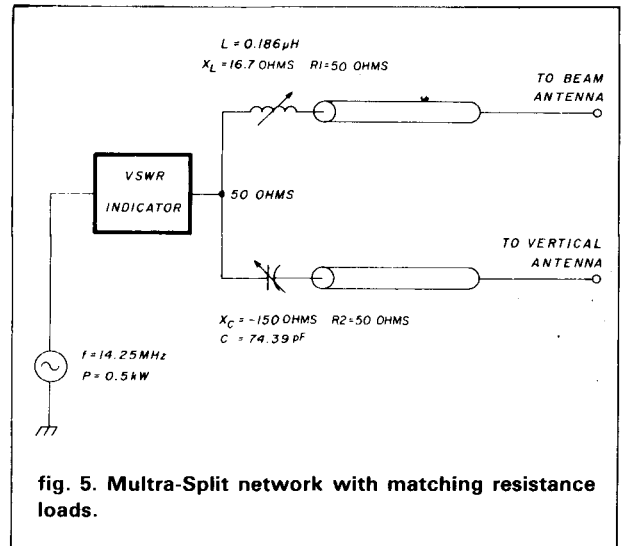

fig. 5. Ultra-Split network with matching resistance loads.

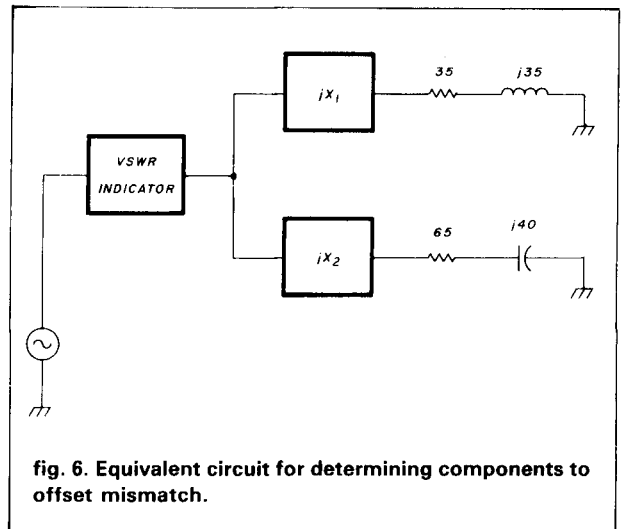

fig. 6. Equivalent circuit for determining components to offset mismatch.

## circuit variations

Combinations of  $X_L$  and  $X_C$  can be selected to accomplish different power splits.

In many cases, it's more practical to use variable capacitors and inductors to obtain the exact power ratio; in others, a fixed capacitor can be made equivalent to a variable unit by using a variable or tapped coil in series with a capacitor.

If you want to operate a transmitter over several bands of frequencies, provisions should be made to switch in different size components. The size and rating of components from a voltage and current standpoint are determined in the usual manner for any network.

It should be noted that the circuit works on the principle that both lines are equal in magnitude and non-reactive. In the event that one or both of the lines are mismatched, it's necessary to adjust the  $X_C$  or  $X_L$  or

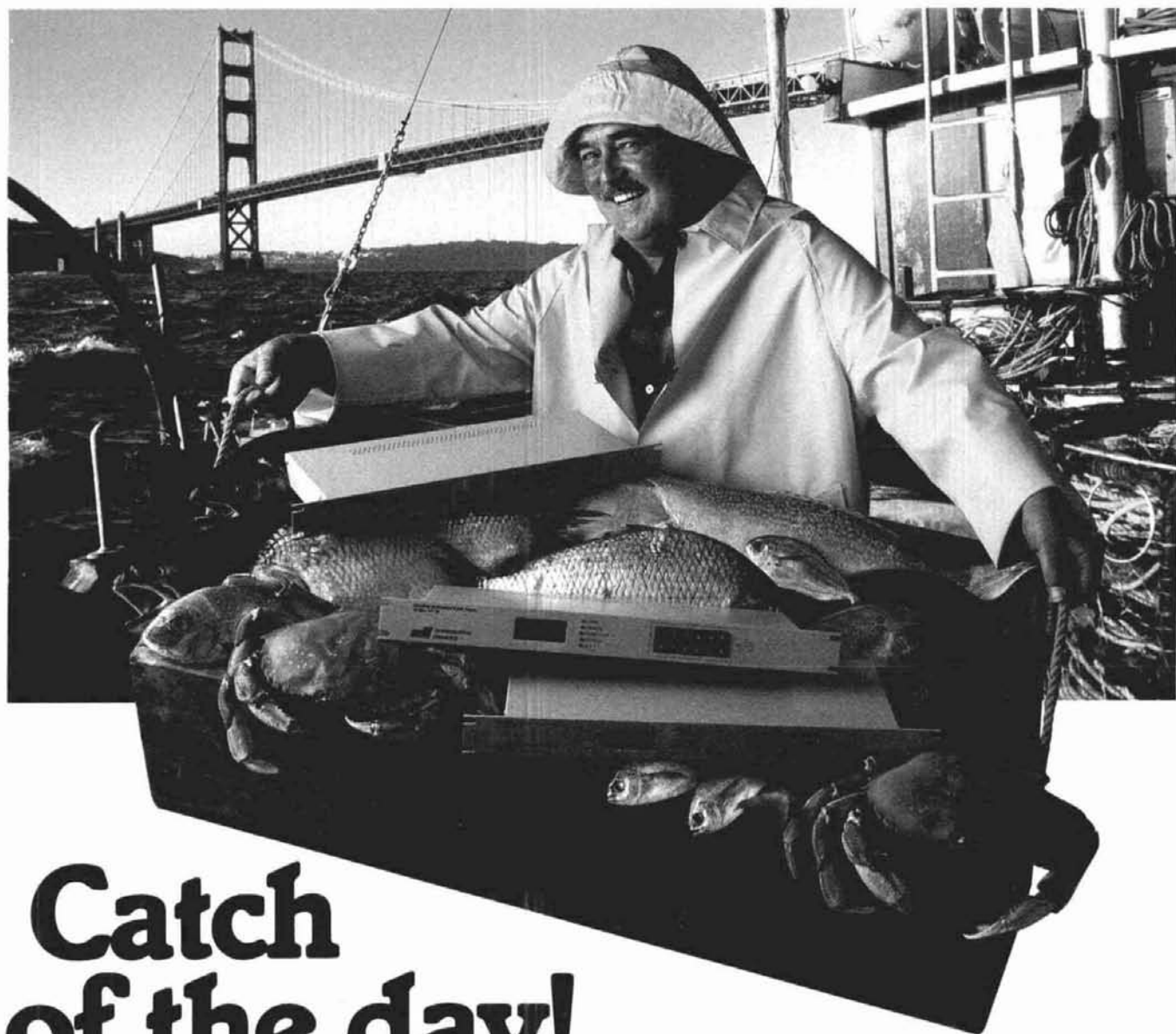

# Catch of the day!

Have you been trawling the bounding main for a new product? We have just netted it—the TP-38 microprocessor controlled community repeater panel which provides the complete interface between the repeater receiver and transmitter. Scuttle individual tone cards, all 38 EIA standard

CTCSS tones are included as well as time and hit accumulators, programmable timers, tone translation, and AC power supply at one low price of \$595.00. The TP-38 is packed like a can of sardines with features, as a matter of fact the only additional option is a DTMF module for \$59.95. This module allows complete offsite remote control of all TP-38 functions, including adding new customers or deleting poor paying ones, over the repeater receiver channel.

Other features include CMOS circuitry for low power consumption, non-volatile memory to retain programming if power loss occurs, immunity to falsing, programmable security code and much more. The TP-38 is backed by our legendary 1 year warranty and is shipped fresh daily. Why not set passage for the abundant waters of Communications Specialists and cast your nets for a TP-38 or other fine catch.

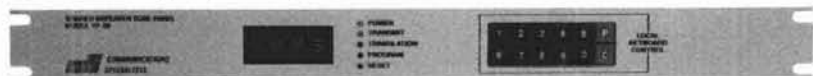

**\$595.00 each**  
**\$59.95 DTMF module**

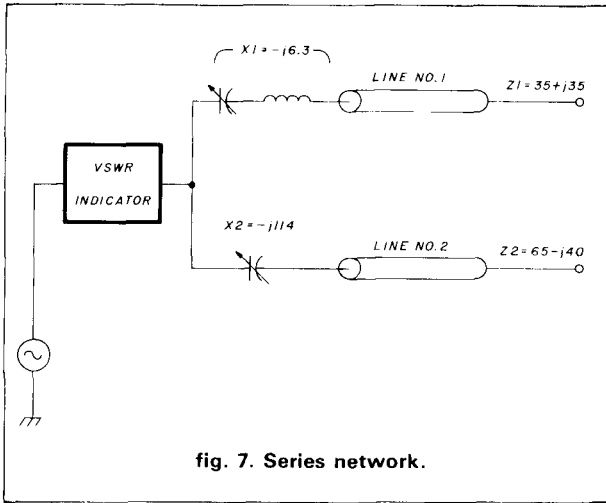

fig. 7. Series network.

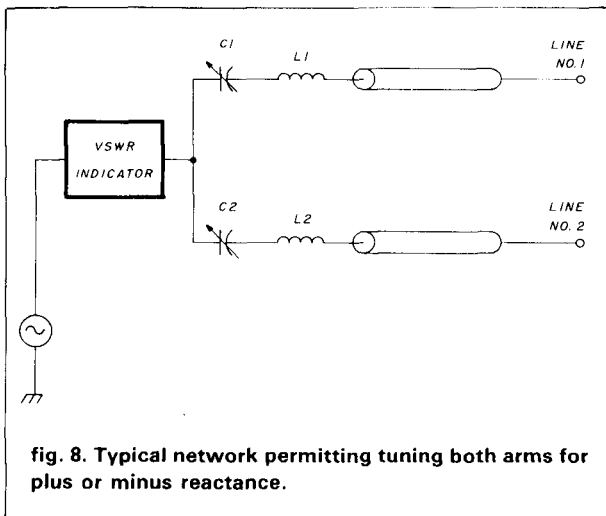

fig. 8. Typical network permitting tuning both arms for plus or minus reactance.

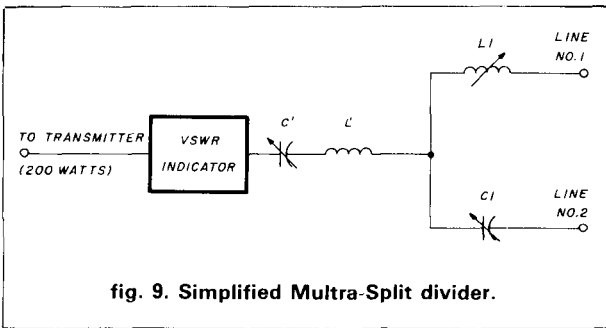

fig. 9. Simplified Multisplit divider.

both to obtain a 50-ohm input for the transmitter. A VSWR indicator at the transmitter output or network input will indicate a match condition.

Where either or both antennas have a large mismatch, the method for determining the combining components becomes somewhat more complex because we have to deal with four variables; that is, two resistances and two reactances. The problem, however, is not too difficult to solve.

Example Assume:

Transmission line 1 =  $35 + j35$ .

Transmission line 2 =  $65 - j40$

Power distribution  $M' = 3.00$  (90 percent/10 percent).

Transmitter impedance 50 ohms.

The equivalent circuit can be represented as in fig.

6.

The values for  $jX1$  and  $jX2$  are of opposite sign and are determined as follows:

$$X1 = \tag{14}$$

$$\left[ \frac{b^2d - 2ea + (b^2d - 2ea)^2 + 4e^2 (b^2c - a^2)}{2 (b^2c - a^2)} \right]^{1/2}$$

where

$X1 =$  net reactance for line 1 (the load reactance),

$$a = R0 - R2 + M'^2 \left( \frac{R2}{R1} R0 - R1 \right)$$

$$b = \frac{2M' R0}{R1 + R2}$$

$$c = R2/R1$$

$$d = R2 R1 \left[ \frac{R2^2}{M'^2} - R1^2 \right]$$

$$e = R1R2 - R0R1 - R0R2 +$$

$$M'^2 \cdot \left( \frac{R2}{R1} \right) \left( \frac{R2^2}{M'^2} - R1^2 \right) \left( \frac{R0 - R1}{R1 + R2} \right),$$

$R0 =$  transmitter resistance = 50 ohms

Substituting the known parameters,  $X1 = j 28.7$  ohms.

Remember that  $X1$  represents the net reactance required for branch one; hence, because we already have  $j 35$  in the circuit we must wash out  $j 6.3$  ohms  $(35 - 28.7) = 6.3$ ) to obtain the required net reactance. This is best accomplished by a series network adjusted to have a reactance of  $-j 6.3$  ohms in series with line 1.

$X2$  is determined from (and will be a negative reactance because  $X1$  is positive).

$$X2 = M' \left[ \frac{R2}{R1} R1^2 + X1^2 - \frac{R2^2}{M'^2} \right]^{1/2} \tag{15}$$

Substitute in Eqn 15  $X2 = -j 154$  ohms. Inasmuch as the reactance for line 2 is  $-j 40$ , we have to add a minus of  $-j 154$  as required by Eqn 15. We obtain this value by using a capacitor which is adjusted to  $-j 114$  ohms.

We can now redraw our circuit as in fig. 7. In practice we should use a circuit that has series networks in both arms because we can adjust these for either

plus or minus reactance, depending upon which side of resonance we are tuned. Fig. 8 is a typical circuit. Due to the fact that we are working with mis-

matched transmission lines, the maximum current and voltages at the input of the lines are determined as follows:

table 1.

Matched condition  
Where R1 = R2 = 50 ohms

P1 percent	X1 ohms	X2 ohms
10	150.00	16.67
20.00	100.00	25.00
30.00	76.38	32.73
40.00	61.24	40.82
50.00	50.00	50.00
60.00	40.82	61.24
70.00	32.73	76.38
80.00	25.00	100.00
90.00	16.67	150.00

table 2.

Mismatched condition  
Where R1 = 35 ohms and  
R2 = 65 ohms

P1 percent	X1, ohms	X2 ohms
10	192.81	12.59
20.00	126.32	18.24
30.00	97.08	28.09
40.00	78.98	38.08
50.00	65.86	48.86
60.00	55.36	61.51
70.00	46.25	77.93
80.00	37.68	102.73
90.00	28.71	153.85

and

$$E_{MAX} = [P \cdot Z_0 \times VSWR]^{1/2} \quad (16)$$

$$I_{MAX} = \left[ \frac{P \times VSWR}{Z_0} \right]^{1/2} \quad (17)$$

where

P = power in watts

VSWR = voltage standing wave ratio,

Z<sub>0</sub> = characteristic impedance of line.

To demonstrate the effect of a mismatch or VSWR vs. a pair of matched lines (Eqns 1, 14, and 15) were used to determine the net reactances required for X1 and X2 for the condition where R1 = R2 = 50 ohms,

table 3.

P1 percent	C1 (PF)3	L1(μH)
10.00	58	0.141
20.00	88	0.204
30.00	115	0.313
40.00	141	0.425
50.00	169	0.545
60.00	202	0.686
70.00	241	0.869
80.00	296	1.146
90.00	389	1.717

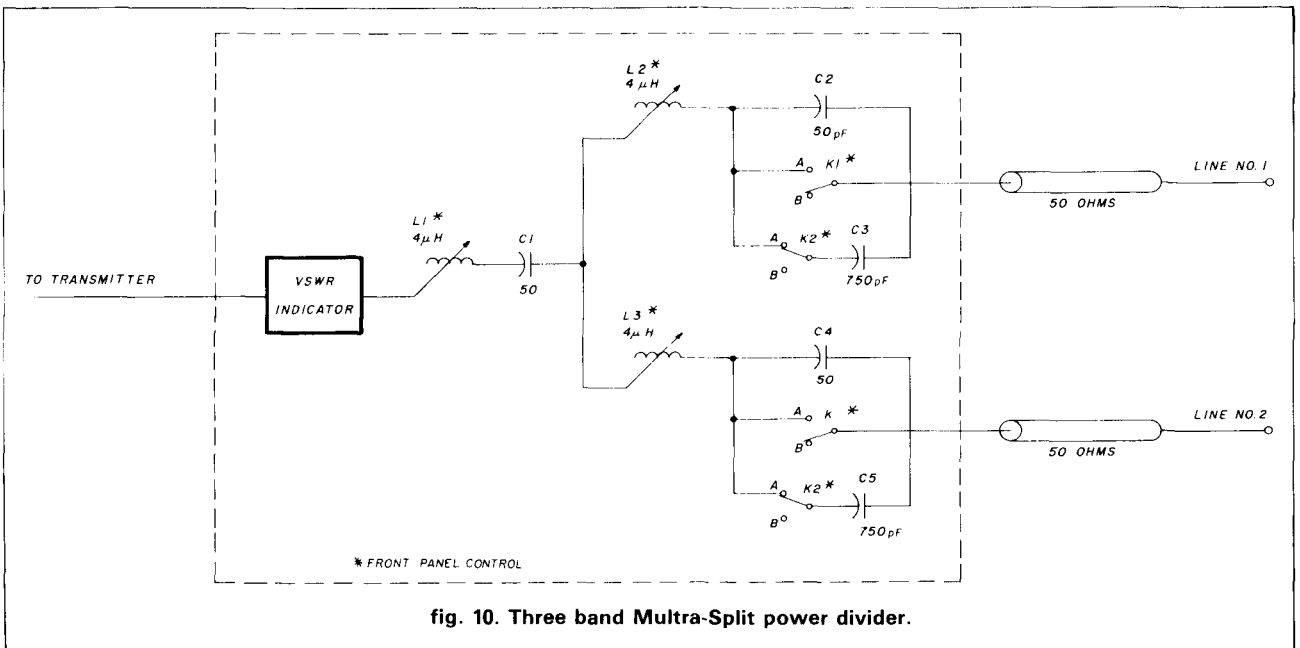

fig. 10. Three band Multisplit power divider.

and  $R1 = 35$  ohms and  $R2 = 65$  ohms. **Table 1** represents the matched condition, whereas **table 2** is for the mismatched condition.

The differences for identical powers is apparent from a study of the tables. In practical applications, series networks in both legs are used with components large enough to handle any mismatch.

### typical multra-split circuits

**Figure 9** illustrates a typical stripped-down version of a Multra-Split power divider for one Amateur band.

$C' L'$  is a series circuit that can be adjusted either side of resonance to wash out any residual reactance due to mismatch on the transmission lines, while  $L1$  and  $C1$  are the components used to control the percentage of power to each antenna.

**Table 3** furnishes typical component values for  $C1$  and for power division from 10 percent to 90 percent where one antenna is a beam and the other a vertical. This divider is for 20 meters with the center frequency being 14.25 MHz. We are using the inductive branch for high power and assume both lines could be mismatched.

$C1$  would be a variable capacitor of approximately 25-400 picoFarad, while  $L1$  would be a variable inductor of approximately 2.5  $\mu$ H. The voltage and current ratings of the components would be determined by the transmitter power and VSWR.

The series circuit  $L' C'$  would consist of a fixed inductor of 4  $\mu$ H, while a variable capacitor of 25-400 picoFarad would be used for  $C'$ .

**Figure 10** illustrates another Multra-Split power divider, used by the author, to cover the bands of 10, 15, and 20 meters. It will handle 1 kW of power.

### conclusions

The Multra-Split network provides a simple method of dividing power between two loads or antennas of identical or dissimilar polarization radiation angles. It can be used to improve HF communications because it works on the principle of taking advantage of radiation angle diversity. Electrically, the principle is straightforward and it should provide a practical economical method for power splitting.

### acknowledgement

Thanks to George Jacobs, W3ASK, for his valuable suggestions and help in preparing this article.

### references

1. G. Jacobs and T. Cohen, *Short Wave Propagation Handbook*, C.Q. Publishing, Hicksville, N.Y.
2. John H. Mullaney, P.E., *Improved H.F. Transmission Reception by Use of Power Splitting*, Multronics, Inc., Gaithersburg, Maryland, June, 1969.
3. John H. Mullaney, "A Method for Pre-Sunrise Power Reduction," *Broad-cast Engineering*, November, 1967.

ham radio

## K.V.G. CRYSTAL PRODUCTS



### 9 MHz CRYSTAL FILTERS

MODEL	Applic-ation	Band-width	Poles	Price
XF-9A	SSB	2.4 kHz	5	\$53.15
XF-9B	SSB	2.4 kHz	8	72.05
XF-9B-01	LSB	2.4 kHz	8	95.90
XF-9B-02	USB	2.4 kHz	8	95.90
XF-9B-10	SSB	2.4 kHz	10	125.65
XF-9C	AM	3.75 kHz	8	77.40
XF-9D	AM	5.0 kHz	8	77.40
XF-9E	FM	12.0 kHz	8	77.40
XF-9M	CW	500 Hz	4	54.10
XF-9NB	CW	500 Hz	8	95.90
XF-9P	CW	250 Hz	8	131.20
XF-910	IF noise	15 kHz	2	17.15

### 10.7 MHz CRYSTAL FILTERS

WRITE FOR FULL DETAILS OF CRYSTALS AND FILTERS

Export inquiries invited.

Shipping \$3.50

### MICROWAVE MODULES EQUIPMENTS

Use your existing HF or 2M rig on other VHF or UHF bands.

#### RECEIVE CONVERTERS

MMk1691-137	\$259.95
MMk1296-144G	159.95
MMc439-ATV	94.95
MMc432-28(S)	79.95
MMc144-28(HP)	84.95
MMc144-28	64.95

#### LINEAR TRANSVERTERS

MM11296-144G	\$329.95
MMx1268-144	259.95
MM1435-28(S)	299.95
MM1432-28(S)	279.95
MM1144-28(R)	319.95
MM1144-28	189.95

#### LINEAR POWER AMPLIFIERS

2M	70cm
MML144-30-LS	\$109.95
MML144-50-S	149.95
MML144-100-S	209.95
MML144-100-LS	249.95
MML144-200-S	399.95
MML432-30-L	\$219.95
MML432-50	199.95
MML432-100	379.95

### ANTENNAS

2M	10XY-2M	\$69.95	LOOP YAGI	1268-LY	\$49.95
70cm	70/MBM28	\$39.95		1296-LY	49.95
	70/MBM48	64.95		1691-LY	59.95
	70/MBM88	94.95		order loop yagi connector extra	



Send 66¢ (3 stamps) for full details of all our VHF & UHF equipments and KVG crystal products.

Shipping FOB Concord, Mass.



(617) 263-2145

SPECTRUM INTERNATIONAL, INC.

Post Office Box 1084

Concord, MA 01742, U.S.A.

### BASEBALL CAP

How about an attractive **BASEBALL** style cap that has name and call on it. It gives a jaunty air when worn at Hamfests and it is a great help for friends who have never met to spot names and calls for easy recognition. Great for birthdays, anniversaries, special days, whatever occasion. Hats come in the following colors:

**GOLD, BLUE, RED, KELLY GREEN**

Please send call and name (maximum 6 letters per line).

**UFBC-81** \$6.00



### I.D. BADGES

No ham should be without an I.D. badge. It's just the thing for club meetings, conventions, and get-togethers, and you have a wide choice of colors. Have your name and call engraved in either standard or script type on one of these plastic laminated I.D. badges. Available in the following color combinations (badge/lettering): white/red, woodgrain/white, blue/white, white/black, yellow/blue, red/white, green/white, metallic gold/black, metallic silver/black.

**UID** Engraved I.D. Badge

\$2.50

Ham Radio's Bookstore

Greenville, NH 03048

Please Enclose \$2.00 to cover shipping and handling



# cylindrical feedhorns revisited

Another look  
at this  
popular method

The subject of feedhorn design is obviously of interest to Amateurs and experimenters everywhere; nine years after my first *ham radio* article on this topic, and almost three years after the second, was published, inquiries are still being received.<sup>1,2</sup>

The concept of the open-ended waveguide for use as an antenna or primary feed for a parabolic reflector was covered in the first article; the second article addressed impedance matching to space. Because of limited test pattern facilities, the matter of pattern shape was not thoroughly discussed.

It was only recently that I had an opportunity to make radiation patterns of the cylindrical feedhorn on

a professional pattern range with commercial equipment. These tests were made at frequencies between 3.7 and 4.2 GHz because the feedhorns were designed for that frequency range. The results, however, apply equally well on Amateur frequency bands such as 1296, 2304, 5700 and above, wherever parabolic reflectors would normally be used.

A scalar feedhorn is generally defined as one employing an RF "choke" mounted on the outside of the horn near the open end. Commercial feedhorns often employ chokes consisting of four to six concentric rings, either diecast or milled from a block of aluminum. The purpose is to choke off currents that would otherwise flow on the outside surface of the horn, thereby producing unwanted radiation and power loss. A photograph of a typical scalar feedhorn choke is shown in **fig. 1**.

A scalar choke can be fabricated for use at Amateur frequencies by forming copper strips into concentric circles and soldering them onto a brass washer. The height of the strips should be slightly less than a quarter wavelength, spaced approximately 0.2 wavelengths. The latter is not critical, but care should be taken to assure that the circles are concentric.

The choke shown in the second article was a large flat brass washer soldered to a short cylinder that slid over the outside of the horn for positioning. This type of choke is very effective in improving horn efficiency, and is much easier to fabricate than the scalar choke.

Radiation patterns recently made show that the pattern shape using the flat choke is slightly asymmetrical at some frequencies, causing a few degrees of "squint." That is, the axis of the beam tends to be off the horn axis, and this tends to vary with frequency, as shown in **fig. 2**. The shape of the pattern, and in particular its symmetry, is highly important in terms of overall antenna efficiency when a feedhorn

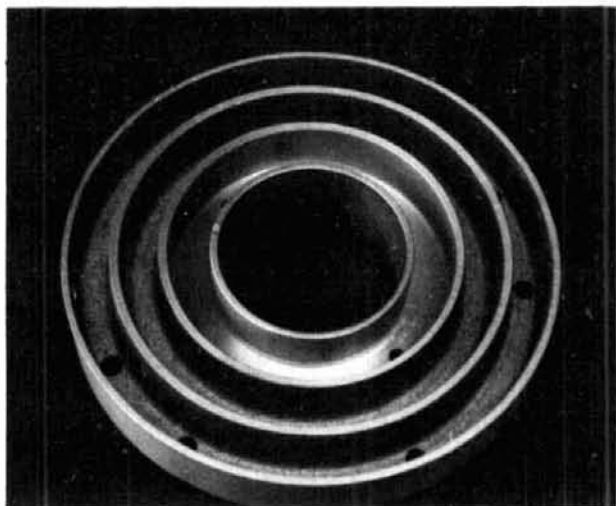

fig. 1. Photograph of typical scalar choke.

By Norman J. Foot, WA9HUV, 293 East Madison Avenue, Elmhurst, Illinois 60126

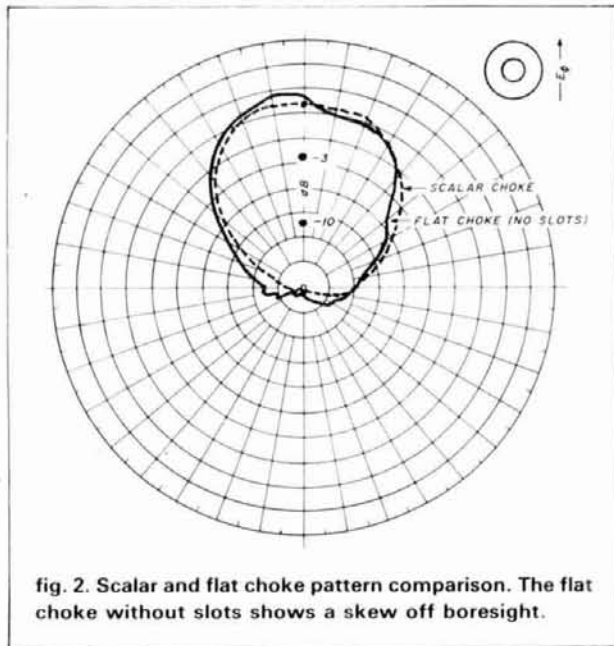

fig. 2. Scalar and flat choke pattern comparison. The flat choke without slots shows a skew off boresight.

is used together with a parabolic reflector, especially when used over an appreciable frequency band.

### overcoming squint

The addition of a single set of resonant slots cut into the choke overcomes the squint problem. The slots act as RF chokes in a manner similar to the concentric rings of the scalar choke. With the addition of the slots, squint is removed and patterns are smooth and axially symmetrical. **Figure 3** is a photograph of a flat choke with slots. Thus, while the addition of a flat choke to the cylindrical feedhorn produces a good match to free space, the slots choke off residual currents that would otherwise flow on the outside of the horn and result in squint. **Figure 4** and **5** compare the patterns of a feedhorn employing a scalar choke with the same horn using a slotted choke. Boresight gains are identical, and 3 and 10-dB beamwidths are for all practical purposes identical. **Figure 4** also shows what can happen when the choke is not used.

### slot orientation function of polarization

In operation, the slots are oriented along the direction of polarization. When used with vertical polarization, the slots are located one above the other. Rectangular slots cut in a conducting ground plane are sometimes used as radiating antennas; they are normally excited by connecting a coaxial cable across the small dimension. The resulting RF current tends to flow parallel to the large dimension of the slot. The slot performs like a dipole except that the directions of voltage and current are reversed. The long dimension is approximately equal to a half-wavelength.<sup>3</sup>

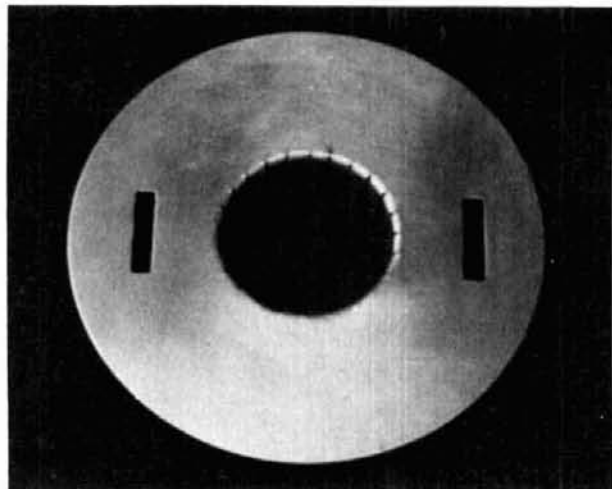

fig. 3. Photograph of slotted choke.

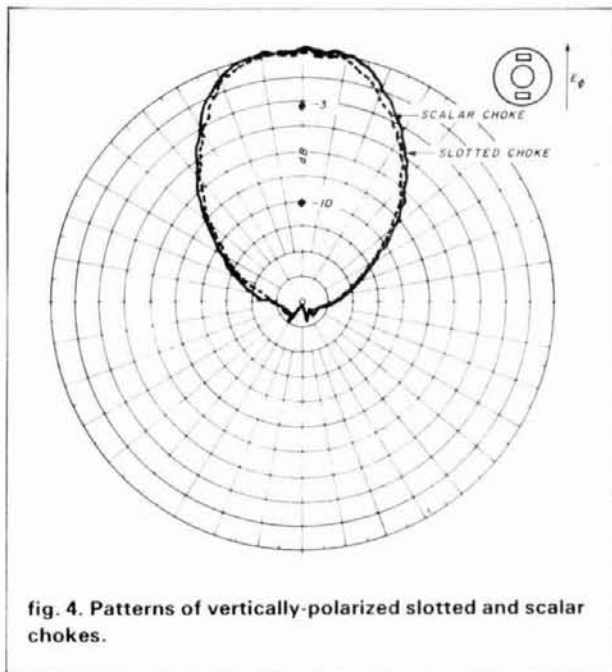

fig. 4. Patterns of vertically-polarized slotted and scalar chokes.

When currents flowing radially outward on the flat choke encounter slots oriented in the wrong direction (i.e., normal to the direction of slot current flow), the current tends to be inhibited and the slots act like RF chokes. Choking action is most effective when the slots are resonant at the RF operating frequency. The slots for use at 4 GHz were cut 1.4 inch long and 0.25 inch (3.17 x 0.63 cm) wide. The slot width is not critical as long as it is much smaller than a wavelength.

If the antenna system uses both horizontal and vertical polarization, such as is the case with TVROs two sets of slots should be used to avoid having to rotate the choke 90 degrees to change polarization. A choke of this kind is illustrated in **fig. 6**. Not shown are a

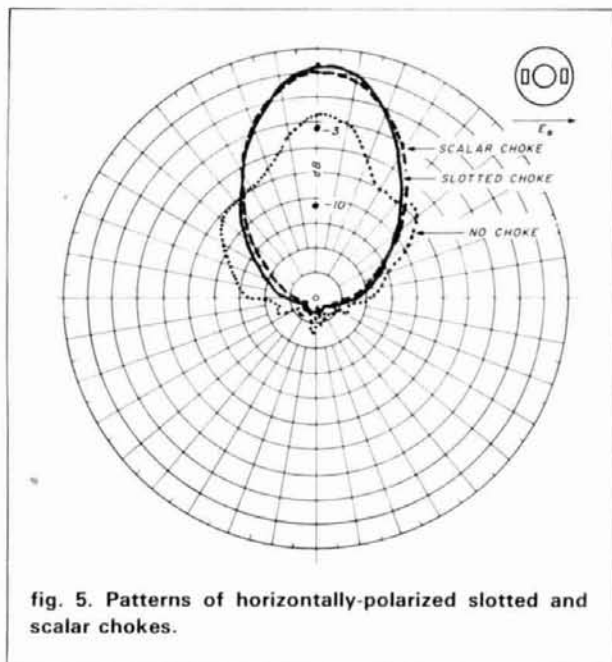

fig. 5. Patterns of horizontally-polarized slotted and scalar chokes.

pair of orthogonally mounted monopoles inside the horn, each of which responds to its respective polarization. Two sets of slots would probably work well with circular or cross-polarization as well, although this has not been confirmed by test.

### choke dimensions

The 4 GHz choke shown in fig. 3 has a 7-inch (17.8 cm) OD and a 2-1/2 inch (6.35 cm) diameter hole at its center which slides over the 2-1/2 inch (6.35 cm) OD horn. The inside diameter of the horn is 2-1/4 inches (5.72 cm) and it is 4 inches (10.16 cm) long. A mechanical drawing of this choke is illustrated in fig. 7. In the pattern tests, the optimum location for the slotted choke was found to be in the plane of the open end of the horn. Pushing the choke forward had very little effect on the gain or patterns, but gain falls off somewhat as the choke is moved to a position behind the horn opening.

Choke dimensions can be scaled for operation at other frequencies. The 2304 MHz choke should be 12 inches (30.48 cm) OD and the center hole should be slide-fit with the 3.9 inch (9.91 cm) diameter of the horn. One-pound coffee can make ideal horns for 2304 MHz, since their ID is slightly less than 4 inches (10.16 cm). The choke slots should be 2-1/2 inches (6.35 cm) long and about 3/8 inch (0.95 cm) wide.

At 1296 MHz, the choke diameter becomes relatively large. If scaled from fig. 7, it would be 21 inches (53.3 cm). To avoid excessive shadowing, especially when using a relatively small dish, a choke diameter as small as 18 inches (45.72 cm) provides reasonably good performance at 1296 MHz.

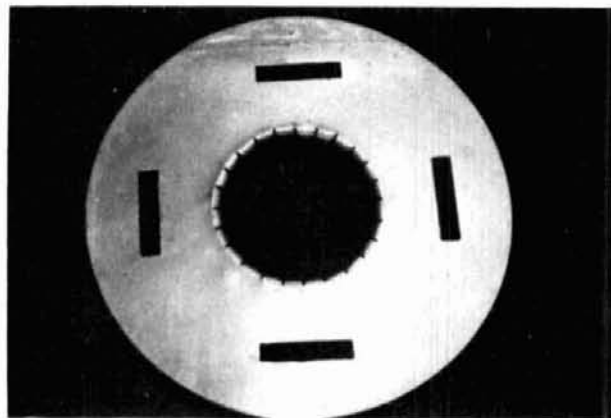

fig. 6. Double slotted choke.

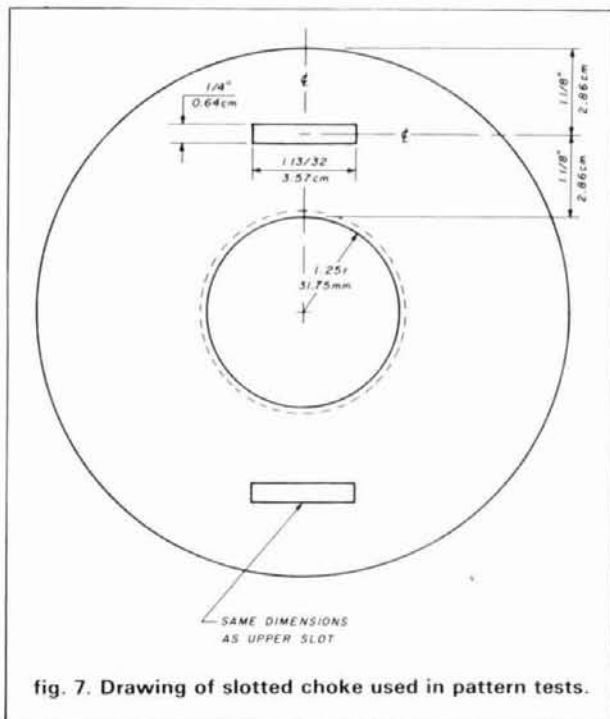

fig. 7. Drawing of slotted choke used in pattern tests.

A 7/8-inch (2.22 cm) ID brass tube makes an ideal horn for the 10.0-10.5 GHz band. The choke should be 2.7 inches (6.86 cm) OD with 9/16 x 1/8 inch (1.43 x 0.32 cm) slots.

Reader inquiries may be addressed to Footronics Engineering Inc., 293 East Madison Avenue, Elmhurst, Illinois 60126, in care of WA9HUV. Please enclose an SASE.

### references

1. Norman J. Foot, WA9HUV, "Cylindrical Feed Horn for Parabolic Reflectors", *ham radio*, May, 1976, page 16.
2. Norman J. Foot, WA9HUV, "Second Generation Cylindrical Feedhorns," *ham radio*, May, 1982, page 31.
3. John D. Kraus, W8JK, *Antennas*, McGraw-Hill, New York, 1950, page 353.

ham radio

New

New

# THE STANDARD OF EXCELLENCE

## Definitely Superior!

# AZDEN PCS-5000

COMMERCIAL — GRADE



**UNPRECEDENTED WIDE FREQUENCY RANGE:** Covers 140,000-153,000 MHz in steps that can be set to any multiple of 5 kHz up to 50 kHz.

**CAP/MARS/NAVY MARS, BUILT IN:** The wide frequency range facilitates use of CAP and ALL MARS FREQUENCIES including NAVY MARS. **COMPARE!**

**TINY SIZE:** Only 2 inches high, 5½ inches wide and 7¼ inches deep!

**MICROCOMPUTER CONTROL:** Gives you the most advanced operating features available.

**UP TO 11 NONSTANDARD SPLITS:** **COMPARE** this with other units!

**20 CHANNELS OF MEMORY IN TWO SEPARATE BANKS:** Retains frequency, offset information, PL tone frequency.

**DUAL MEMORY SCAN:** Scan memory banks separately or together. **ALL** memory channels are tunable independently. **COMPARE!**

**MEMORY SCAN LOCKOUT:** Allows you to skip over channels you don't want to scan.

**TWO RANGES OF PROGRAMMABLE BAND SCANNING:** Limits are quickly reset. Scan ranges separately or together with independently selective steps in each range. **COMPARE!**

**BUSY SCAN AND DELAY SCAN:** Busy scan stops on an occupied channel. Delay scan provides automatic auto-resume.

**DISCRIMINATOR CENTERING (AZDEN EXCLUSIVE PATENT):** Always stops on frequency desired when scanning.

**PRIORITY MEMORY AND ALERT:** Unit constantly monitors one memory channel for signals, alerting you when channel is occupied.

**LITHIUM BATTERY BACKUP:** Memory information can be stored for up to 5 years even if power is removed.

**FREQUENCY REVERSE:** Allows you to listen to repeater input frequency.

**ILLUMINATED KEYBOARD WITH ACQUISITION TONE:** Keys are easily seen in the dark, and actuation is positively verified audibly. **CRISP, BACKLIT LCD DISPLAY:** Easily read no matter what the lighting conditions!

**DIGITAL S/R/F METER:** Shows incoming signal strength and relative transmitter power.

**MULTI-FUNCTION INDICATOR:** Shows a variety of operating parameters on the display.

**FULL 16-KEY TOUCHTONE PAD:** Keyboard functions as auto-patch when transmitting.

**MICROPHONE CONTROLS:** Up/down frequency control and priority channel recall.

**PL TONE GENERATOR BUILT IN:** Instantly program any of the standard PL frequencies into the microcomputer. **COMPARE!**

**TRUE FM, NOT PHASE MODULATION:** Unsurpassed intelligibility and audio fidelity. **COMPARE!**

**HIGH/LOW POWER:** Select 25 watts or 5 watts output — fully adjustable.

**SUPERIOR RECEIVER:** Sensitivity is better than 0.15 microvolt for 20-db quieting. Commercial-grade design assures optimum dynamic range and noise suppression. **COMPARE!**

**DIRECT FREQUENCY ENTRY:** Streamlines channel selection and programming.

**OTHER FEATURES:** Rugged dynamic microphone, built-in speaker, mobile mounting bracket, remote speaker jack, and all cords, plugs, fuses and hardware are included.

EXCLUSIVE DISTRIBUTOR: DEALER INQUIRIES INVITED FOR YOUR NEAREST DEALER OR TO ORDER:  
**AMATEUR-WHOLESALE ELECTRONICS TOLL FREE...800-327-3102**  
 8817 S.W. 129th Terrace, Miami, Florida 33176 Telephone (305) 233-3631 Telex: 80-3356



MANUFACTURER:

**JAPAN PIEZO CO., LTD.**

1-12-17 Kamirenjaku, Mitaka, Tokyo, 181 Japan

Telex: 781-2822452

✓ 179



# Message Master™

## Real-voice message system For any repeater or base

Now you can communicate vital information even when the station you are calling is not on the air — with Message Master. Message Master is a solid state voice recording system which can record messages just by listening to you speak, store messages in memory, and deliver messages on demand. If you can't be there to deliver your messages let Message Master deliver them for you - any messages in any language and in your own voice!

Message Master connects easily to any radio system for remote access: repeaters, base stations, even transceivers. It can even be connected to an autopatch device to exchange messages between your radio system and the telephone network.

Message Master is a multi-user system with mailbox style personalized message service for a hundred users. With 8 minutes of message storage it can store hundreds of messages simultaneously making it ideal for large, active repeater groups.

Would you like your callsign identifications, tail messages, and bulletin messages sent in real-voice? Message Master can send them too. Record several identification messages and it will even send a different ID each time. Almost like magic, Message Master knows when to send identifications and tail messages so it needs no special control signals from your base or repeater.

Call or write for further information before you make another wasted call.

Commercial users: Ask for a brochure on the Message Master Electronic Dispatcher with group and all call messaging.



- Create messages just by talking. Message Master's 'real-voice' technique saves YOUR VOICE in digital memory to deliver messages in your own voice, language and dialect.
- Mailbox-style operation gives individual message delivery service to 100 system users.
- Easily added to any repeater or base station for remote operation with only four connections.
- Special features include callsign identifications, tail messages, and bulletin messages.
- Digital message storage provides instant playback of stored messages.
- Modular memory meets your exact needs from 2 to 8 minutes of total message storage.

## Serving all your repeater needs

- Mark 4 Repeaters and Repeater Controllers are THE PERFORMANCE LEADERS with real voice, more autodial numbers, more synthesized voice and more features.
- Mark 3 Repeaters offer the winning combination of high performance and high value.
- LR-1 Repeaters boast superb RF circuitry at an economical price.
- MR-4 Receivers with 7 helical resonators are the only receivers to choose in harsh RF environments.
- PA-100 Amplifiers with rugged TMOS power FETs give you a continuous duty high power signal.



COMING SOON: A 4-channel receiver voting system which operates on true signal-to-noise ratio to extend your coverage by linking to remote receivers.

✓ 143



KENDECOM INC.  
MICRO CONTROL SPECIALTIES

23 Elm Park  
Groveland, MA 01834  
(617) 372-3442



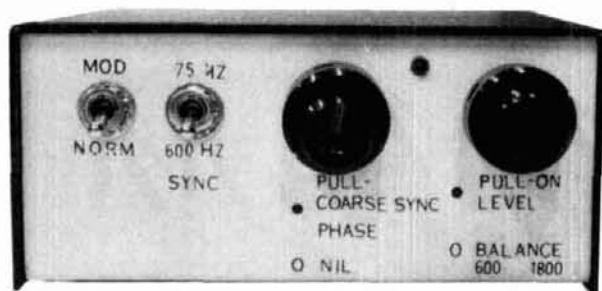

## two-tone signal generator

Check linearity  
of SSB transmitters  
with an easy-to-read  
oscilloscope display

This article describes a two-tone test generator for checking SSB transmitter linearity. In addition to supplying two low-distortion audio tones to the microphone input of a transmitter, it has three additional features. The first permits the generation of a "bow tie" display on an oscilloscope in which linearity shows up as a straight line, which is easily judged, rather than as two interlaced sine waves, which are not so easily judged. The second feature modulates the level of the two tones at a pseudo voice rate, permitting operation at voice average power levels while viewing a two-tone. (Some transmitter power supplies "droop" during single-tone or even two-tone operation, reaching their peak power output only with a voice waveform with its corresponding low average power.) The third feature is crystal control of the frequencies, which permits accurate frequency measurement of a transmitter without the necessity of generating the carrier.

This generator was conceived as a school project almost 20 years ago. Assigned to build a circuit board, we made a two-tone generator that used two twin-tee oscillators, with the high oscillator locked to the third harmonic of the low oscillator with a small capacitor. When the output of the low oscillator, through a phase shift network to compensate for phase shift in the transmitter, was fed to the X input of a scope and the transmitter output was fed to the normal Y input, a

"bow tie" pattern resulted, making judging distortion easy. But the tones had significant distortion and the third harmonic lock was unstable. Over the years I tried to improve it by various means, including the use of function generator ICs. This design, which offers maximal features but minimal complexity, is the final product.

### operation

For normal operation the output is connected to the microphone input or phone patch input of the transmitter (see fig.1). The oscilloscope is usually connected to the RF output via an X10 probe; the RF output is then connected to a 50-ohm dummy load. Turn the transmitter and the test generator on and adjust the balance and level controls for minimum valleys and peak output as shown in fig. 2A. The switches should be in the "normal" and "600 Hz" positions. The scope output may be connected to the "external trigger" or "channel B" input to the scope and used to synchronize the display. Varying the phase control will shift the display horizontally.

For a "bow tie" pattern, shift the scope output of the generator to the X input of the scope. Adjust the X channel gain for full horizontal display. With the transmitter on, a pattern similar to fig. 3 should occur. Rotate the pattern with the phase control to produce a "bow tie" pattern similar to the one shown in fig. 2B. (Figure 2B was taken with a commercially built Amateur transceiver and appears to be perfect, yet slight variations in linearity are clearly visible in the "bow tie" pattern of fig. 2B.) Figure 4A shows a pattern produced by a transmitter with severe crossover distortion caused by low screen grid voltage and fig. 4B depicts the same with a "bow tie" display. Figures

By Bill McLagan, YB9ATA/WA7AQN,  
c/o MAF, Box 239, Sentani, Irian Jaya,  
Indonesia 99000

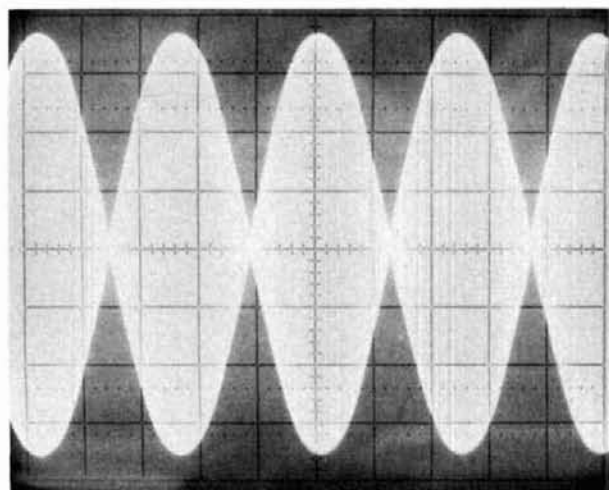
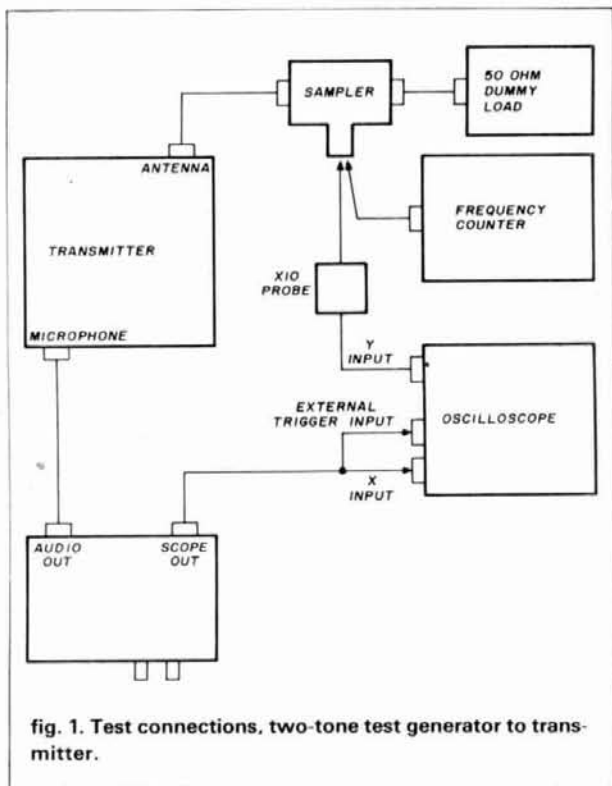

fig. 2A. Output of a commercial transceiver, standard two-tone pattern.

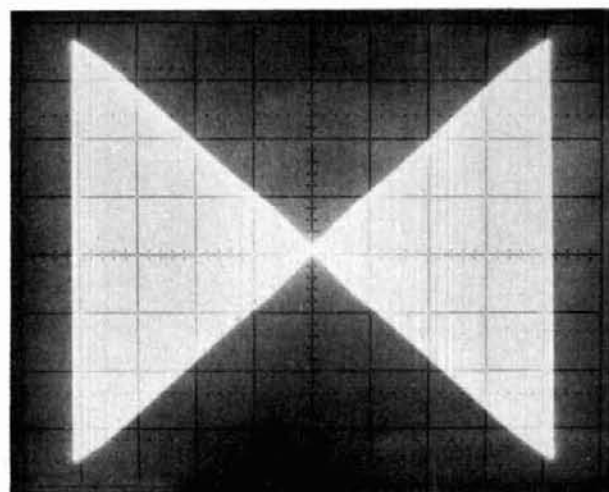

fig. 2B. Output of a commercial transceiver, bow tie pattern.

table 1. Measured power output of a transceiver under test.

Single tone	120 watts
Two-tone	60 watts
Two-tone, pseudo voice	15 watts
Voice ("e" as in "hello")	15 watts
Voice, as above, 20 dB compression	50 watts

5A, 5B, 6A, and 6B show two different kinds of distortion and the resulting patterns.

Figure 7 shows a display using the "modulated" feature to reduce the average power to that encountered during modulation. The synch switch is changed to 75 Hz to synchronize the display. Relative power levels for each mode as measured on a commercially built Amateur transceiver are shown in table 1.

For precise frequency measurement, a single tone is fed into the transmitter. The audio frequency is added to (for LSB) or subtracted from (for USB) the counter reading to arrive at the correct carrier frequency.

### theory, digital section

U1, a CD4060, contains an oscillator and a 14-stage binary divider. Y1 can be either a 3.579545 TV crystal (producing output frequencies of 582 and 1746 Hz) or

a 3.6864 crystal (producing output frequencies of 600 and 1800 Hz). The tenth binary stage puts out a 3600 Hz square wave, which is fed to U3, a CD4017 decimal counter set up to reset on the third count, resulting in a 1200-Hz asymmetrical square wave.

Both the 3600 Hz signal and the 1200 Hz signal are divided by two by U2 to produce 1800-Hz and 600-Hz symmetrical square waves. The 1800 Hz signal is locked to either the leading or trailing edge of the 600 Hz wave via differentiator C17 and R4, which triggers the reset input of the 1800 Hz divide-by-two section. S4 permits triggering from either the Q or  $\bar{Q}$  output of the 600-Hz divide-by-two. This insures that the generator will always start up with the same phase relationship and permits changing the phase 180 degrees to compensate for the less-than-360 degree phase shift available from the "fine" phase control. U7 further divides down the signal to provide 75 Hz

# NEW!

# Satellite Communications Training from NRI!

Move into commercial satellite communications and home satellite TV with NRI's latest training breakthrough

Explore Every Aspect of Satellite Transmission and Reception As You Assemble, Install, and Train With the Complete TVRO System Included in Your Course

With today's satellite technology a call to Paris is as clear and as easy to make as a call next door . . . executives use video conferencing to "meet" without leaving their offices . . . simultaneously, a billion people witness a single event (a soccer game, an inauguration, a benefit rock concert) . . . and scientists explore the mysteries of outer space without leaving their labs.

These amazing applications of satellite technology have opened up exciting new opportunities for the technician trained to install, maintain, troubleshoot, and repair satellite communications equipment.

Home Satellite TV is Just at the Start of Its Explosive Future

In suburban backyards and alongside country farmhouses, home satellite TV systems are springing up all across the country.

Already there are over a million TVRO (Television Receive-Only) systems in place in the U.S. alone, and experts predict that by 1990, a remarkable 60% of U.S. homes will have a satellite dish.

New Jobs, New Careers for the Trained Technician

As an NRI-trained technician, you can concentrate on consumer-oriented TVRO equipment or use your NRI training to build a career servicing the larger commercial or military equipment used to transmit and receive voice, data, and video signals.

NRI Brings Satellite Technology Down to Earth

NRI trains you thoroughly in basic electronics, communications, and television principles. Using the remarkable NRI Discovery Lab® and your digital multimeter, you perform critical experiments, tests, and measurements. Then, using your NRI Antenna Applications and Design Lab, you assemble and test various types of antennas and matching sections.

You then concentrate on both commercial and

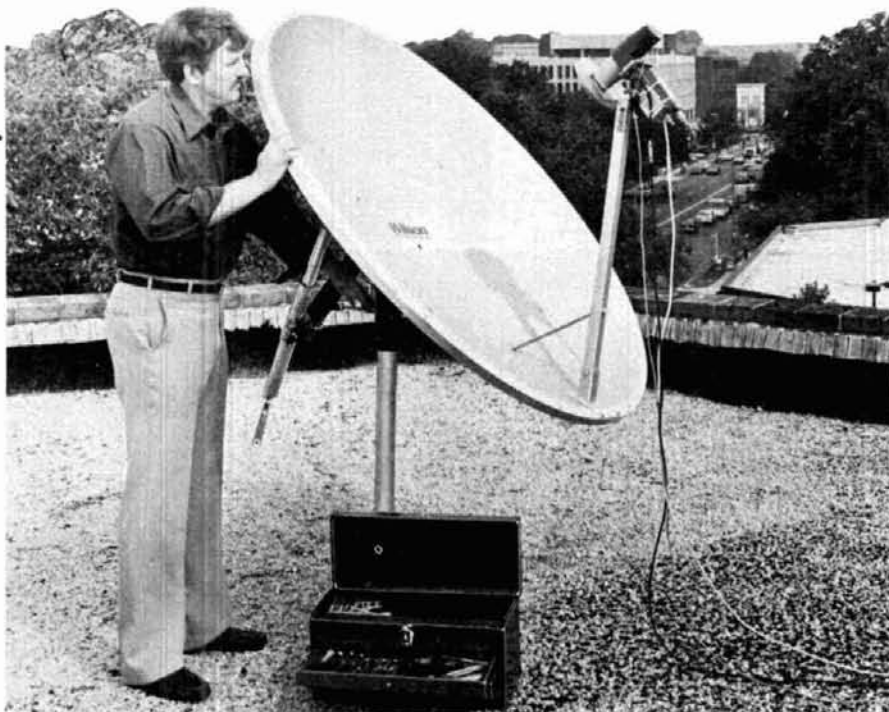

consumer satellite earth station equipment, putting theory to practice as you assemble and install the complete satellite antenna system included in your course.

Your Home Satellite TV System Brings Theory to Life!

Your Wilson TVRO system comes complete with 5' parabolic dish antenna system, low-noise amplifier (LNA), down converter, receiver, low-loss coaxial cable, and even a permanent polar mount.

By training with an actual TVRO system, you'll come to understand first-hand the function and operation of a satellite earth station. And once completed, your TVRO system will provide the best television entertainment available—direct from the satellite to your home.

Train the Uniquely Successful NRI Way

It's hands-on training, at home . . . designed

around the latest state-of-the-art equipment. You discover by doing . . . and you do it at your own comfortable pace.

Built into your NRI training is the enormous experience of our development specialists and instructors, whose training skills and personal guidance are available to you on a one-to-one basis.

Make Your Move Into the Future Today! Send for Your FREE NRI Catalog

Only NRI can train you at home for an exciting and rewarding career as a satellite communications technician. And now is the time to act. Mail the coupon to us today. You will receive your 100-page catalog free. It details our training methods and materials and our more than 70 years of successful innovation in hands-on career training.



All Equipment Included With Your Training.

More Details? CHECK—OFF Page 110

## NRI

SCHOOLS

McGraw-Hill Continuing Education Center  
3939 Wisconsin Avenue, Washington, DC 20016



We'll give you tomorrow.

CHECK ONE FREE CATALOG ONLY

- Satellite Communications
- Computer Electronics with Microcomputers
- Robotics & Industrial Controls
- Video Electronics Servicing
- Electronic Design Technology
- Digital Electronics

- Data Communications
- Communications Electronics
- Industrial Electronics
- Basic Electronics
- Telephone Servicing
- Small Engine Servicing
- Appliance Servicing

- Automotive Servicing
- Air Conditioning, Heating, Refrigeration, & Solar Technology
- Building Construction
- Locksmithing & Electronic Security

For Career courses approved under GI bill,

check for details.

Name (Please Print) \_\_\_\_\_

Age \_\_\_\_\_

Street \_\_\_\_\_

City/State/Zip \_\_\_\_\_

Accredited by the National Home Study Council

20-026

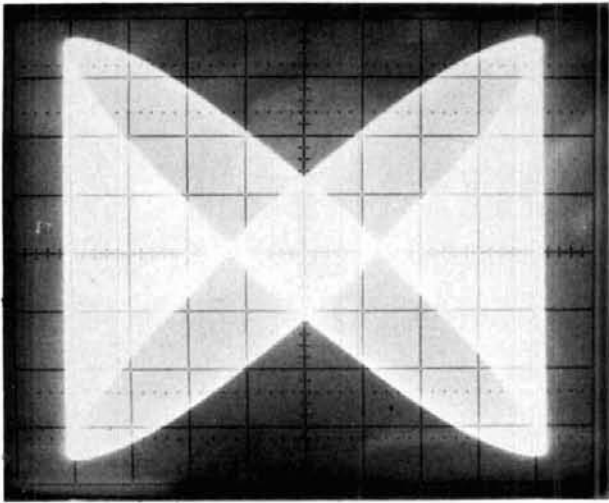

fig. 3. Bow-tie pattern before adjustment of phase control.

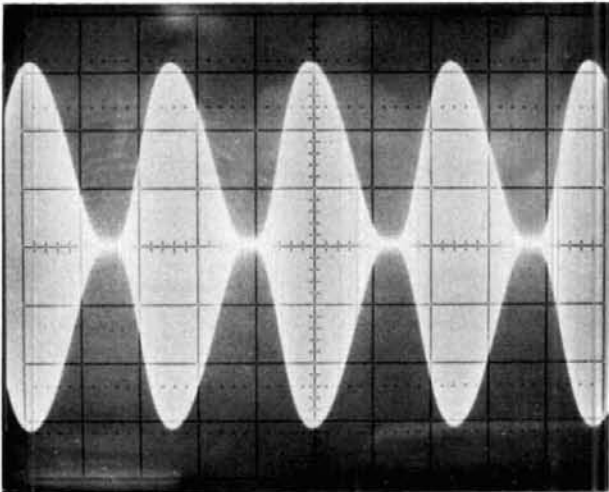

fig. 4A. Severe crossover distortion, standard position.

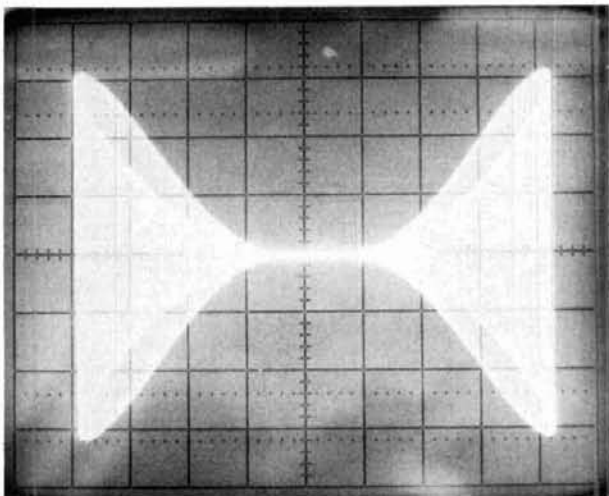

fig. 4B. Severe crossover distortion, bow-tie pattern.

for the modulator and 0.146 Hz for the LED "on" indicator. The LED flash provides a visible indication of the operation, yet avoids the 10- to 20-mA drain of a steady lamp.

### theory, analog section

R5, C5, R6, and C6 provide two poles of lowpass RC filtering to reproduce a near sine wave of 1800 Hz. I've found that when converting a fixed frequency square wave to sine that multiple RC lowpass sections, operated well beyond cutoff and followed by an op amp to recover gain, is simple and effective. In this case, very low distortion is needed so U4B is configured as a multiple-feedback bandpass filter. U4A is set up similarly, but for the 600 Hz channel. The series resistors in the RC sections may have to be changed slightly to adjust for equal gain through each channel and/or set the output of the bandpass filters

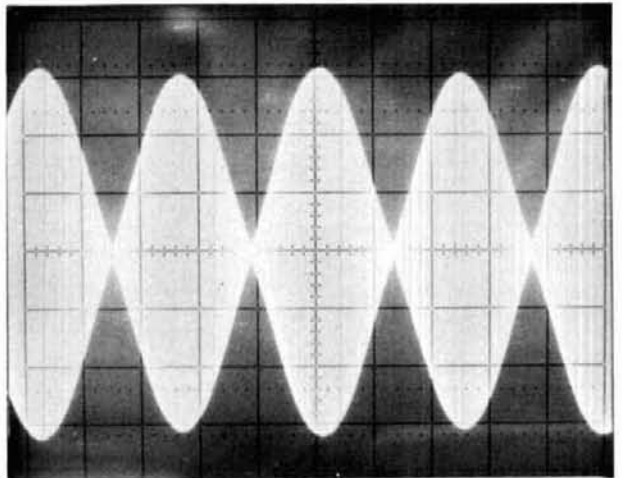

fig. 5A. Minor distortion, higher levels emphasized, standard pattern.

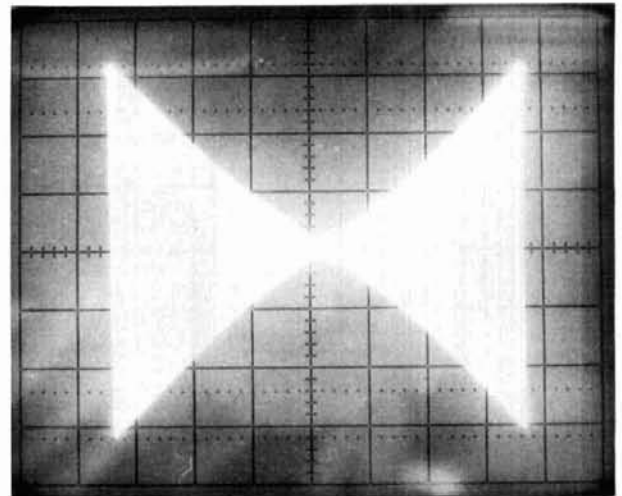

fig. 5B. resulting bow-tie pattern.



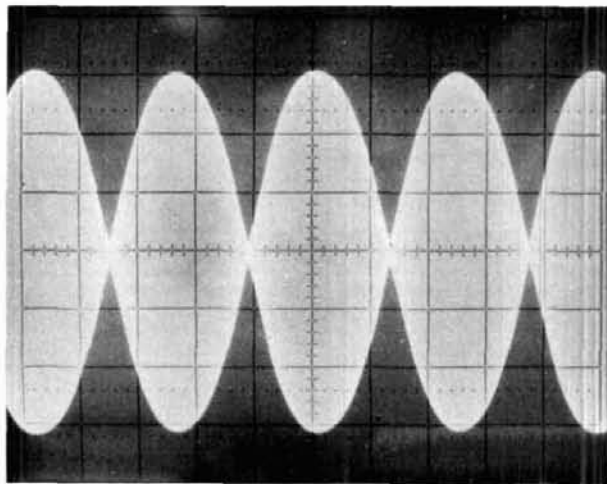

fig. 6A. Minor distortion, higher levels deemphasized, standard pattern.

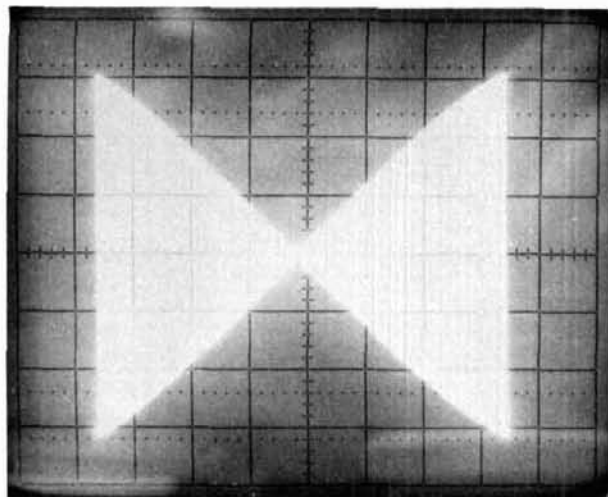

fig. 6B. Resulting bow-tie pattern.

to approximately 1 volt RMS. Both signals are mixed together at the balance potentiometer and go to the transmitter through a voltage follower, U4C, and the level control. Up to this point, the circuit is similar to any conventional two-tone generator.

To obtain the "bow tie" pattern, the low tone must be sent to the X channel through a phase shifter to compensate for phase shift in the transmitter. U4D inverts the 600 Hz tone and feeds one side of phase shift network C13 and potentiometer R20. Nearly 360 degrees of phase shift is possible. Voltage follower U5B presents a high impedance load to the output of the phase shift network and drives the scope isolation transformer, T1. Note that the secondary of T1 is kept floating from the chassis. Without DC isolation, severe problems with ground loops often occur. Care must also be taken with oscilloscopes that have a simple X input because they can be easily overdriven by the several volts available at the scope output. A 500-ohm to 500-ohm transformer could be used as well.

To provide the modulated function, the 75 Hz square wave is converted to a near sine wave by three poles of RC filtering followed by gain recovery stage U5A. The 75 Hz signal enters the AGC input of U6, varying the output at a 75 Hz rate.

### construction

I built the prototype using perf board, IC sockets, and point-to-point wiring using 30 gauge wire. Later I made a circuit board. Either way works fine. In the unit shown (see photo 1), I used some exotic dual-section pots with push-pull switches from my junk box, but normal pots will work just as well. I also added an extra 9-pin plug to allow the use of individual adapter cables to various transceiver microphone inputs and a switch to key the transmitters on. The case, battery holder, and switches came from Radio

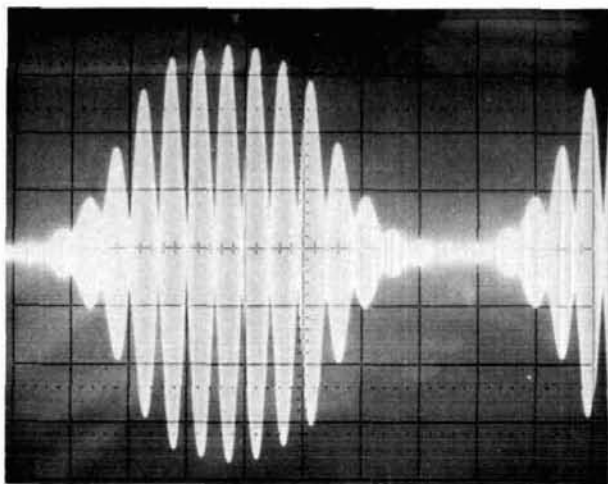

fig. 7. Pseudo voice pattern using "Modulated" functions.

Shack. Mylar capacitors should be used in the filter sections and the phase shift network. The 0.1  $\mu$ F capacitor shown in the power supply line should be placed directly across pin 16 and 8 of U1.

### alternatives

One alternative that might be tried is using a 32 kHz watch crystal. In this case, R1 should be changed to 10 Megohms and R2 to 680 or 750K. Only four stages of binary division would be required to produce 4096 Hz at the input of U2A, resulting in input tones of 2048 Hz and 682.66 Hz. The TL084 and LM353 ICs were used because they produce very little distortion. An LM324 and an LM348 could be used if resistors were added from the output of each amp to either ground or  $V_{cc}$  to cause the IC to always supply current in one direction. The crossover glitch is very visible on a sine wave. Don't omit the load resistors on the transformers; if you do, significant distortion will result.



WORLDWIDE DISTRIBUTION

ICOM DAY!  
SATURDAY, FEB. 1st

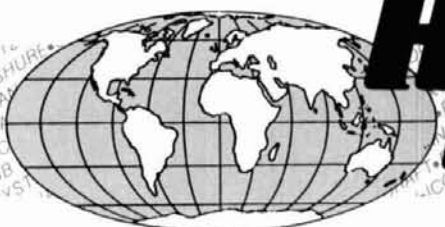

# HAM RADIO OUTLET

## 6 STORE BUYING POWER

### KENWOOD TS-940S



TOP-OF-THE LINE  
HF TRANCEIVER

~~\$1799.95~~

GREAT PRICES. CALL

### KENWOOD HAND-HELDS

#### TH-21AT/41AT

Compact.  
Only 2.4" W, 4.74" H,  
11" D. Outstanding  
performers in an  
ideal package size.



**TR-2600A**  
Deserves its well-  
earned reputation  
as the leading HT

CALL FOR LOW,  
LOW PRICE

CALL TOLL FREE

### US TOWER CORPORATION

**MA-40**  
40' TUBULAR H.D. MAST

Regular **\$745**  
SALE! **\$549**

**MA-550**  
55' TUBULAR H.D. MAST

Regular **\$1245**  
SALE! **\$899**

Why You Should Buy-

1. Will handle 10 Sq. Ft. 50 mph
2. Pleases neighbors with tubular streamlined look
3. In stock for quick delivery
4. Other models at great prices



IN STOCK FOR IMMEDIATE DELIVERY



#### ELH-230D



2 METER  
3 IN/30 OUT

CALL FOR PRICE

NEW OAKLAND  
LOCATION

### ICOM

#### IC-R7000



25 MHz-1300 MHz

IN STOCK FOR IMMEDIATE DELIVERY

### ICOM

SIMPLEX-REPEATER-  
SATELLITE



**IC-271H**  
2 Meters  
100 Watts  
All mode

#### IC-471H

430-450MHz  
74 Watts  
All mode



GREAT PRICES. CALL



#### W-51 TOWER SALE

51' CRANK-UP 9 SQ. FT.  
WINDLOADING

**\$899**

UNBELIEVABLE  
PRICE!



FREE  
SHIPMENT  
Most items UPS  
surface

## All Major Brands in Stock Now!

# CALL TOLL FREE (800) 854-6048



Toll free including Alaska & Hawaii. Phone Hrs: 9:30 a.m. to 5:30 p.m. Pacific Time. California and Arizona customers call or visit nearest store. California and Arizona residents please add sales tax. Prices, specifications, descriptions subject to change without notice.



WORLDWIDE DISTRIBUTION

NEW OAKLAND  
LOCATION

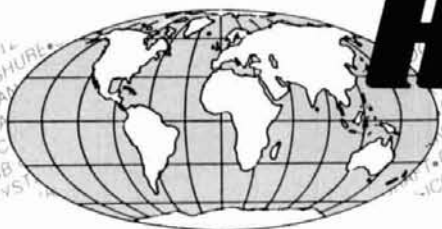

# HAM RADIO OUTLET

## 6 STORE BUYING POWER

### ICOM IC-R71A



Superior Grade General Coverage Receiver

\$799

SALE! CALL FOR PRICE

### ICOM IC-37A



IC-27A (25W, 2M, FM)

IC-27H (45W, 2M, FM)

IC-37A (25W, 220MHz, FM)

IC-47A (25W, 70cm, FM)

CALL FOR LOW, LOW PRICE

### ICOM IC-735



The Latest in ICOM's Long Line of HF Transceivers

CALL FOR LOW, LOW PRICE

### ICOM DAY! SAT., FEB. 1st, 1986 at Anaheim & Oakland Stores

- ★ In-store drawings each hour. Come and register to win!
- ★ Grand prize for in-store drawing: **IC-02AT 2-Meter Digital Readout Handheld**
- ★ No purchase necessary to register for in-store drawings.
- ★ Special in-store and (800) # pricing at all locations.
- ★ ICOM Personnel to demonstrate new equipment.

### ICOM LATEST EDITION

#### IC-3200A DUAL BANDER

Covers Both  
2 Meters  
& 70 cm



AT GREAT LOW, LOW PRICES

### ICOM

#### IC-1271A

NEW



1.2 GHz Transceiver:  
The First Full-featured  
1240-1300 MHz Transceiver  
AT GREAT LOW, LOW PRICES

### ICOM

#### HAND-HELDS

#### VHF/UHF



IC-02AT  
IC-04AT



IC-2AT  
IC-4AT



IC-3AT

CALL FOR LOW,  
LOW PRICE

## All Major Brands in Stock Now!



**Bob Ferrero W6RJ**  
President

**Jim Rafferty N6RJ**  
VP So. Calif Div.  
Anaheim Mgr.

**ANAHEIM, CA 92801**  
2620 W. La Palma  
(714) 761-3033, (213) 860-2040  
Between Disneyland & Knotts Berry Farm

**BURLINGAME, CA 94010**  
999 Howard Ave.,  
(415) 342-5757. George, Mgr. WB6DSV  
5 miles south on 101 from SFO

**OAKLAND, CA 94606**  
2210 Livingston St.,  
(415) 451-5757. Don, Mgr. N6IPE  
Hwy. 17 to 23rd Ave. Exit

**SAN DIEGO, CA 92123**  
5375 Kearny Villa Rd.  
(619) 560-4900. Glenn, Mgr. K6NA  
Hwy. 163 & Claremont Mesa Blvd.

**PHOENIX, AZ 85015**  
1702 W. Camelback Rd.  
(602) 242-3515. Bob, K7RDH  
East of Hwy. 17

**VAN NUYS, CA 91401**  
6265 Sepulveda Blvd.  
(818) 988-2212. Al, Mgr. K6YRA  
San Diego Fwy. at Victory Blvd.

FREE  
SHIPMENT  
Most items UPS  
surface

## CALL TOLL FREE (800) 854-6048

Toll free including Alaska & Hawaii. Phone Hrs: 9:30 a.m. to 5:30 p.m. Pacific Time. California and Arizona customers call or visit nearest store. California and Arizona residents please add sales tax. Prices, specifications, descriptions subject to change without notice.



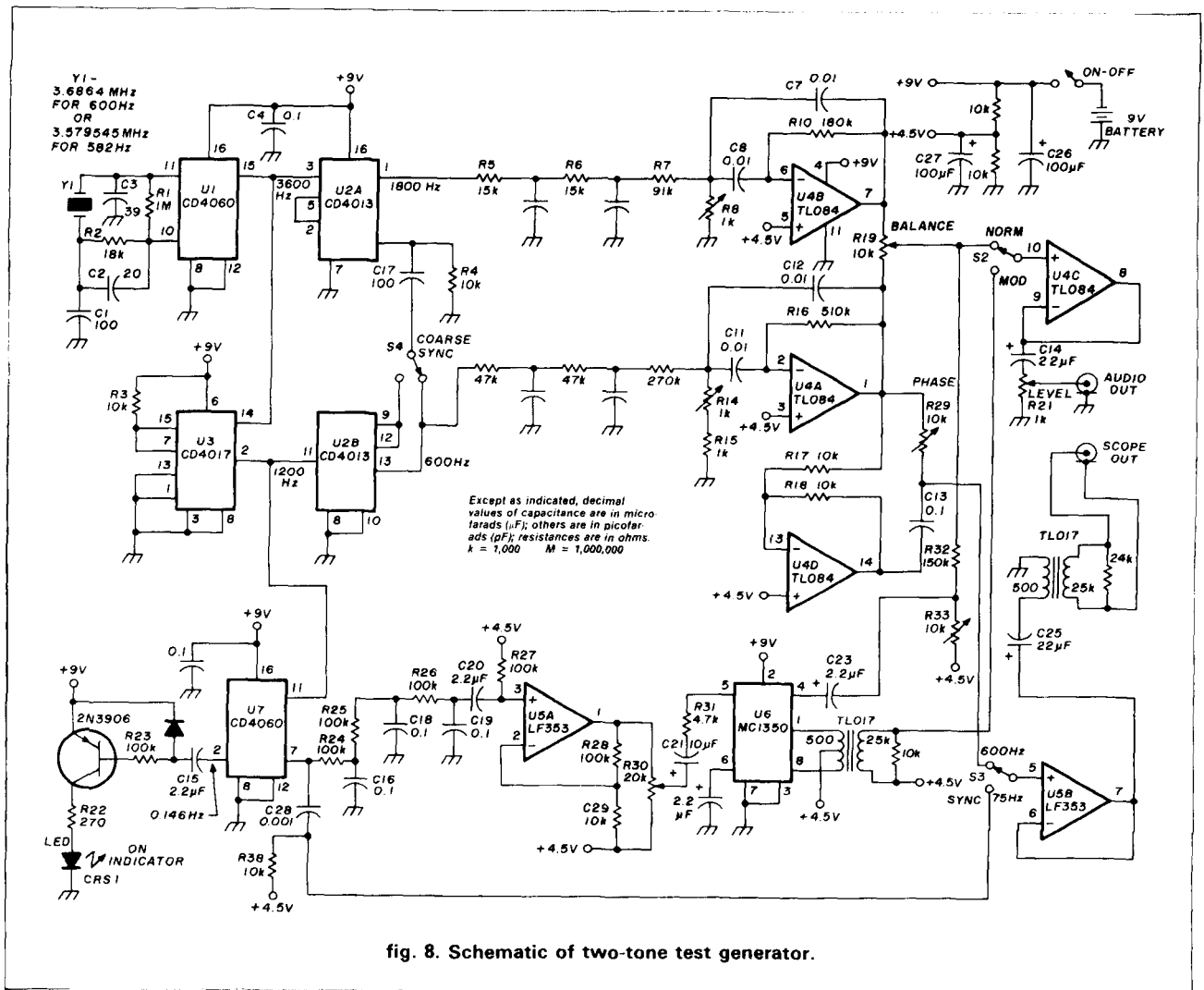

If you want to operate the two-tone test generator from an external AC or DC supply, or to ground the case to some external test equipment, an isolation transformer must be added to the audio output. In this case, T1 would not be needed, and the scope could be driven directly from voltage follower U5B. I tried this in one case and it worked fine. Again, don't forget to terminate the transformer correctly! The power supply can be anything from 8 to 14 volts but must have very low ripple. I would recommend a three-terminal regulator in this case.

### testing the circuit

Plug in the digital ICs. Use some form of current limiting in the power supply — to begin with, a 10-ohm resistor in series with a battery or a current limiting power supply. Turn the unit on and determine that normal current is flowing. Check for 3600 Hz, 1800 Hz, 1200 Hz, 600 Hz, 75 Hz, and 0.146 Hz at the places shown. If the lamp begins to flash every 5 seconds or so, then you can be sure most of it is working.

Plug in U4 and U5. Place a scope probe at the output of the 1800 Hz sine wave generator, U4B, and adjust R8 for maximum. Approximately 2 volts peak-to-peak should be present at this point. If the level is too high, causing distortion, and everything else checks out, increase the values of R5 and R6. In the same way, check out the 600 Hz sine wave generator. Move the scope to the output connector. Look for about 2 volts peak-to-peak of combined 600 Hz and 1800 Hz as the balance control is varied (with level at maximum) and for normal operation of the level control. Check at the output of U5A for a 75 Hz sine wave.

Put the scope on the output again, adjusting for 1800 Hz only. Put the S2 in the "mod" position and adjust R33 and R30 to produce approximately 100 percent modulation of the 1800 Hz tone with a peak level equal to the level in the "normal" position. Some interaction is present between these two controls, so several adjustments may be necessary. Turn the balance control for only a 600 Hz tone and check for approximately the same peak voltage in the "mod"

and "normal" positions. The only glitch I've noticed in building several units is a tendency to oscillate when the level control is set at maximum. This occurred on a unit that used ribbon cable to connect the controls to the PC board, and since the level control is rarely at maximum in operation, I decided to ignore it.

### conclusion

A two-tone generator with a "bow tie" pattern makes it easy to check linearity in an SSB transmitter. In fact, I found I had to be careful because I ended up trying to correct linearity problems that were normal to the equipment! But on the whole, it has made SSB servicing much easier and is certainly less expensive than a spectrum analyzer.

ham radio

### SHORT CIRCUIT HOTLINE

Building a current *ham radio* project? Call the Short Circuit Hotline any time between 9 AM and Noon, or 1 to 3 PM — Eastern time — *before* you begin construction. We'll let you know of any changes or corrections that should be made to the article describing your project.

(See "Publisher's Log," April, 1984, page 6, for details.)

**603-878-1441**

ICOM  
SPECIAL  
IC-735  
\$764.00

W/hand held mic

MA. ★

KENWOOD  
SPECIAL  
NEW  
TM-2550A  
\$414.00

OPEN SIX DAYS A WEEK

Telephone 617/486-3400, 3040  
675 Great Rd., (Rte. 119) Littleton, MA 01460  
1/4 miles from Rte. 495 (Exit 31) toward Groton, Mass.

## We Give You VHF Without VHC\*

(\* - Very High Cost)

Presenting Microwave Modules, the low-cost way to full-featured multi-mode operation on 50 Mhz, 144 Mhz, and 432 Mhz

Expand your HF transceiver's capabilities for less than the cost of a VHF multimode radio

All models feature

- 25 Watts RF output
- Low Noise GaAsFET front end
- Transmit ALC circuit
- RF serised VOX TR switching
- All-mode operation—SSB, CW, FM, AM
- Easy hook-up to your present HF transceiver



New MMT 144/28R GaAsFET  
144 Mhz Transverter  
List Price \$325.00

(Other Models Available)

50Mhz

432 Mhz

1296 Mhz

AVAILABLE FROM:

THE "PX" SHACK

VHF/UHF  
EQUIPMENT

Ivars Lauzums KC2PX  
52 Stonewyck Drive  
Belle Mead, New Jersey 08502  
(201) 674-6013



Hours: 11am - 3pm  
6pm - 10pm



MICROWAVE  
MODULES LTD

✓ 107

# TEL-COM ★

*Electronic Communications*

Authorized Dealers For

KENWOOD &  ICOM

Also displaying the popular accessories needed to complete a HAM STATION . . .

- ARRL PUBLICATIONS • AEA PRODUCTS • AMPHENOL
- ALPHA DELTA • ASTRON • AUSTIN ANTENNAS • AVANTI
- BELDEN • BENCHER • B & W • DAIWA • HAM-KEY
- HUSTLER • KLM • LARSEN • MIRAGE • ROHN
- TELEX/HY-GAIN • VIBROPLEX • WELZ • ETC.

✓ 189

## PACKET RADIO GOES PORTABLE

### GLB ELECTRONICS

presents



#### Model PK1-L

- LOW 25 mA Current drain.
- Designed for portable or solar-powered stations.
- Miniature size—Lightweight
- Rugged all metal, shielded enclosure.
- On-board Lithium Battery RAM backup.
- On-board watchdog for reliability.
- Standard DB-25 Connectors.
- Output signal indicates "Connected" Status.
- Does not require squelched audio.
- Comes with 8K of RAM.
- Remote Command Mode for Unattended operation.
- Hardware command lockout for security.
- Commands compatible with our Model PK1.
- Retains all other features of the Model PK1.
- Extra I/O lines for special applications.

Power requirement:  
9 to 15 Volts DC @ 25 mA typical

Dimensions:  
4.6 X 5.90 X 1.0 inches.

Total Weight:  
12 ozs.

PK1L—Wired and Tested  
List— \$239.95  
Amateur net— \$209.95

#### GLB MODEL TNC-2A KIT

Just when you thought TAPR TNC-2 Kits were a thing of the past, GLB—the first commercial producer of Packet Controllers—joins the "TAPR Revolution" at last!

Hardware  
Software  
Documentation

by TAPR



#### GLB Model TNC-2A Kit

#### COMPLETE KIT ONLY

\$154.95 NMOS

\$169.95 CMOS

+ shipping

Contact GLB for information on our full line of Packet Controllers



## GLB ELECTRONICS, INC.

151 Commerce Pkwy.,  
Buffalo, NY 14224  
716-675-6740 9 to 4

✓ 152

# DOCKING BOOSTER

## Converts Your HT to a Powerful Mobile Unit

30 or 50 watts output  
16 DB GaAs FET pre-amp  
Fits on most car doors  
Mic hang-up clip  
Icom, Yaesu, Kenwood  
2 Meters & 70 cm

# \$149<sup>95</sup>



CMC COMMUNICATIONS, INC.  
5479 Jetport Industrial Blvd. • Tampa, FL 33614  
Phone: 813-885-3996

## Join AMSAT...Today

*Amateur Radio Satellite OSCAR 10 provides:*

- A New Worldwide DX Ham Band open 10 hours a day.
- Rag Chew With Rare DX Stations in an uncrowded, gentlemanly fashion.
- Popular Modes In Use: SSB, CW, RTTY, SSTV, Packet
- Full Operating Privileges open to Technician Class licensee or higher.

*Other AMSAT Membership Benefits:*

**ORBIT Magazine Subscription:**  
Dependable technical articles, satellite news, orbital elements, product reviews, DX news, and more.

**Satellite Tracking Software**  
Available for most popular PCs.

QSL Bureau, AMSAT Nets, Area Coordinator Support, Forum Talks

Construction of Future Satellites For Your Enjoyment!

AMSAT Membership is \$24 a year, \$26 outside North America. VISA and MC accepted.

**AMSAT**  
P.O. Box 27  
Washington, DC 20044

**301 589-6062**



# PRACTICALLY SPEAKING ...

JOE Carr  
K4IPV

## troubleshooting II: solid state circuits

Last month I discussed methods for isolating the dead stage in a radio receiver. These methods — signal injection and signal tracing — are capable of showing us which stage is bad, and from there we can do further troubleshooting to isolate the faulty component.

In this installment, we'll look at another method that I learned more than two decades ago when solid-state car radios first appeared on the market. This method uses a DC voltmeter to isolate the faulty stage. It's not fool-proof, but is well suited to many applications — especially when combined with other methods.

First, let's look at **fig. 1**. Here we have NPN and PNP transistors. In most amplifier circuits the base-emitter voltage will be 0.2 to 0.3 volts for normal germanium transistors (used in older equipment) and 0.6 to 0.7 volts for silicon transistors. In a PNP transistor the base is more negative than the emitter, and in an NPN transistor the base is more positive than the emitter.

Further, the collector will be more positive than either base or emitter in NPN transistors,\* and more negative in PNP transistors. Keep in mind that the term "more negative" can mean "less positive" in some cases. I know that's confusing, so let's try to clean

it up. Consider **fig. 2**. Here we have a cascade chain of three stages in a radio receiver. Each stage consists of a PNP transistor that's powered from

can often be located from the service manual, but in some cases you'll have to fake it. Look for the electrolytic "filter capacitor" used to decouple the

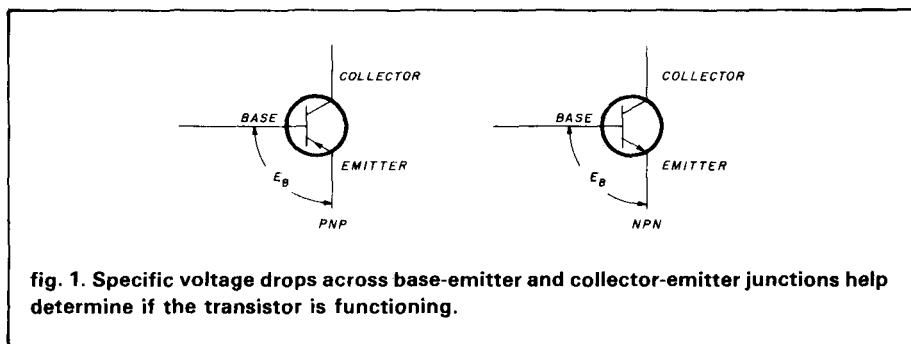

a positive DC power supply. The collectors of the transistors are near ground potential, while the emitters and bases are closer to the +10.5 volt "B+" line. If you measure the collector voltage with respect to ground, you'll find it very slightly positive, while the emitters are at a much higher potential. Thus, the collector's being less positive "causes it to perform as if it were negative."

Voltmeter "A" will measure the potential between the points being measured (in **fig. 1**, an emitter) and ground. If the voltage is near normal at each stage, then we can assume that there are no massive short circuits — but we can't get a hint of whether the stage is working properly.

Voltmeter "B" is connected with its positive electrode on the B+ distribution line, and the other used to probe the emitters of the stages. The B+ line

B+ line (C1 in **fig. 2**). This filter capacitor will denote the proper line (unless you accidentally selected C2!), and usually has enough of a tab to allow connection of the voltmeter probe.

The voltage drop across the emitter resistor of each stage indicates the current conduction of the stage. If the service manual does not give the normal voltage drop, then calculate it from the emitter potential printed on the schematic and the B+ voltage. In the case of the IF amplifier of **fig. 2**, for example, the emitter voltage is 9.1 volts, while the B+ voltage is 10.5 volts. The normal conduction of this stage will be indicated by a voltage drop across the resistor of 10.5 - 9.1, or 1.4 volts. Any radical departure from this value indicates a problem. For example, a shorted transistor would send that conduction voltage (across R3) up to near 10 volts, while

\*If the transistor stage is in saturation, the collector voltage will drop below the base voltage — i.e.,  $V_{CE_{SAT}}$  and  $V_{BE_{SAT}}$

a leaky transistor would place the voltage somewhat lower but still larger than 1.4 volts. Similarly, an open emitter (or other condition that cuts off the stage) will reduce the voltage across the emitter resistor to nearly zero.

We can isolate the defective stage by looking at each emitter voltage in turn. Most often, the defective stage will show up from an anomaly in the emitter conduction voltages.

Radios with NPN transistors in the stages are similarly treated. **Figure 3** shows a radio with NPN transistors powered by a positive-to-ground DC power supply. The collectors of these transistors will be close to the B+ potential, while the emitter and base voltages will be a lot lower. The values shown in **fig. 3** are typical, but they are not to be held as absolute (there are a lot of design choices that could alter the values, so buy and consult the service manual for your rig).

As in the case of the PNP stages, the NPN emitter conduction voltage denotes stage activity. In this type of circuit, however, the reference is ground instead of the B+ line. The principle is the same, however. We can check each conduction voltage in its turn and determine whether any of them are off. Fortunately, there are fewer calculations to make in this type of circuit. The emitter voltage on the schematic is the conduction voltage.

Both of the methods discussed above assume that there is a positive with respect to ground DC power supply. This arrangement is used in all modern American automobiles, so will be found typically in mobile rigs. In home rigs the DC power supply is often the same positive with respect to ground as shown here, but that is not necessarily so. It might be the case that the power supply is negative with respect to ground, or that there are two power supplies (one positive to ground and one negative to ground). The principle in these cases are the same, only the point of voltage reference will change.

Variable frequency oscillators,

whether in a receiver or transmitter VFO, will behave a little differently. In most cases, the DC conduction of the oscillator transistor varies with frequency setting. Typically, the voltage

will be higher at the low end of the band, and lower on the high end of the band (with a smooth transition as the dial is tuned). A sudden discontinuity in this transition might indicate a sud-

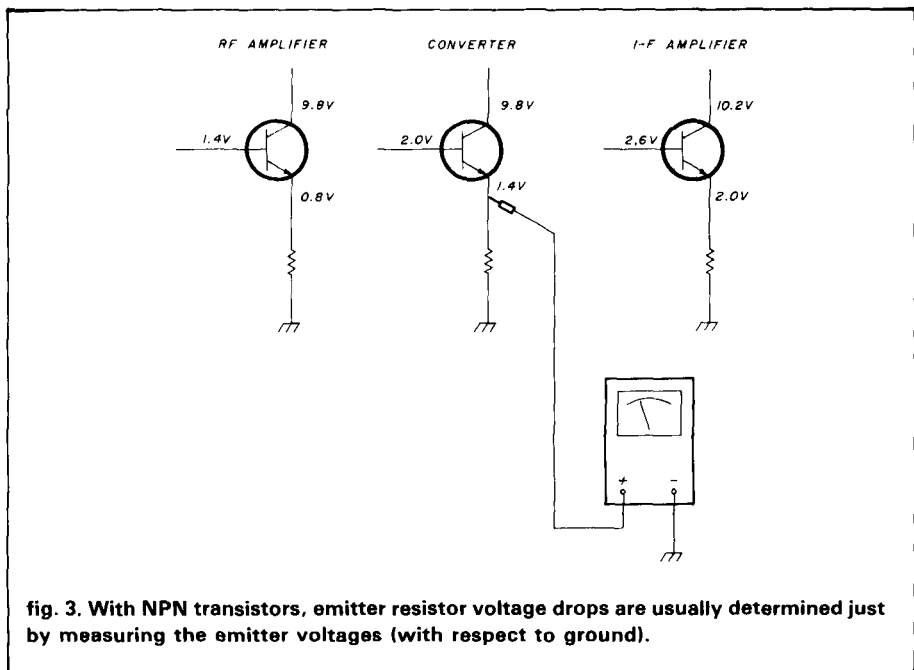
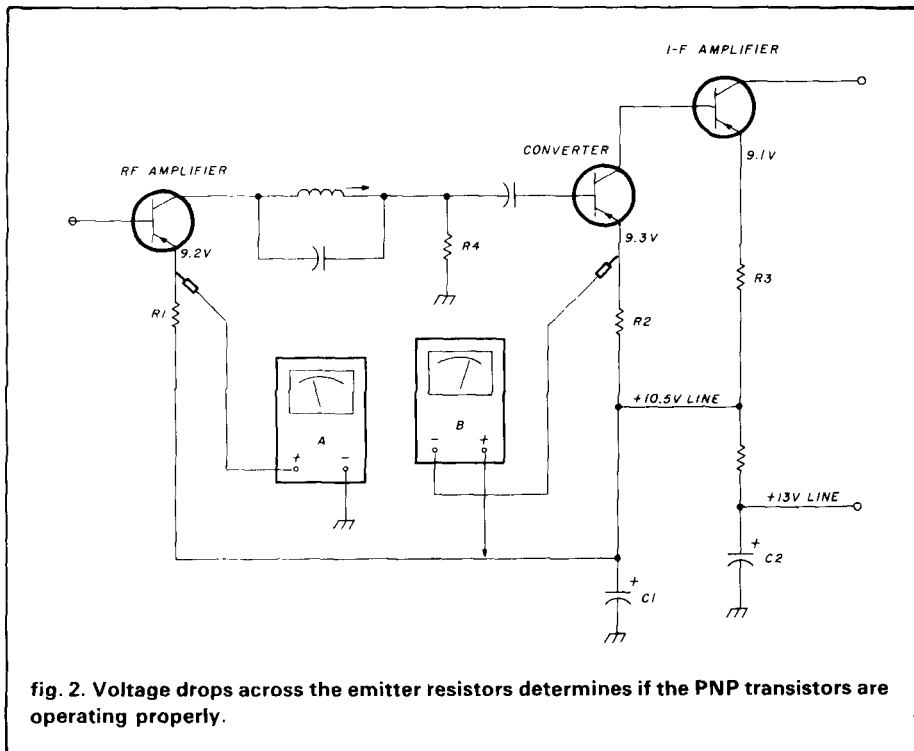

# Kantronics KPC-2 NEW!

## NOW — AX.25 VERSION 2 for ANY computer, the Packet Communicator II

Can you imagine a TNC that has a built-in HF modem and tuning aid, AX.25 version 2 protocol, multiple connects, and both TTL/RS-232 levels at the computer port? Well, it's here! Introducing the **Kantronics Packet Communicator II**, KPC-2 for short.

**KPC-2** is the only TNC you will need, even if you change computers. KPC-2 interfaces with ANY computer that has a serial RS-232 or TTL (C-64/VIC-20) port. The generic command structure, similar to KPC-1 but enhanced, fits any computer, even the PC compatibles.

In addition, KPC-2 features totally new hardware and software — KPC-2 is



Suggested Retail \$219.00

not a clone. And, of course, KPC-2 is enclosed in the now industry standard Kantronics extruded aluminum case. For more information contact Kantronics or a Kantronics dealer.

**Want more information on Packet?**  
Contact us about our new **PACKET VIDEO**, great for a club program or instruction. \$22.50, VHS or BETA format.

**Kantronics**

1202 E. 23rd Street (913) 842-7745  
Lawrence, Kansas 66046

## THE CHAMP



BIRD MODEL 4304

**NO ELEMENTS**  
25-1000 MHZ  
RF SAMPLING PORT

AUTHORIZED **BIRD** DISTRIBUTOR

**Webster**

WEBSTER COMMUNICATIONS INC.  
115 BELLARMINA  
ROCHESTER, MI 48063  
313-375-0420

CALL TOLL FREE  
**800-521-2333**  
**800-482-3610**

✓ 108

## GEM-QUAD FIBRE-GLASS ANTENNA FOR 10, 15, and 20 METERS

Two Elements \$235.00  
Extra Elements \$164.00  
Price is F.O.B. Transcona  
**INCLUDES U.S. Customs  
Duty**

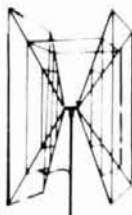

**KIT COMPLETE WITH**  
\*SPIDER  
\*ARMS  
\*WIRE  
\*BALUN KIT  
\*BOOM WHERE  
NEEDED

WINNER OF MANITOBA  
DESIGN INSTITUTE  
AWARD OF EXCELLENCE

*Buy two elements now — a third and fourth may be added later with little effort.*

*Enjoy up to 8 db forward gain on DX, with a 25 db back to front ratio and excellent side discrimination.*

*Ask for our new 2m Quad Kit when you order your Gem Quad. It's FREE for the asking!*

*Get maximum structural strength with low weight, using our "Tridetic" arms. Please inquire directly to:*

## GEM QUAD PRODUCTS LTD.

Box 53  
Transcona Manitoba  
Canada R2C 2Z5  
Tel. (204) 866-3338

## MADISON

Electronics Supply, Inc.  
3621 Fannin St. • Houston, Texas 77004



**BELDEN**

### BELDEN

9913 low loss, solid center conductor, foil & braid shield - excellent product.....45c/ft  
8214 RG8 foam.....43c/ft  
8237 RG8.....40c/ft  
8267 RG213.....52c/ft  
8262 RG-58 cu milspec.....16c/ft  
8000 14ga stranded copper ant. wire.....13c/ft  
8448 8 conductor rotor cable.....31c/ft  
9405 as above but HD-2-16ga, 6-18ga.....52c/ft  
8403 Mic cable 3 condctr & shield.....80c/ft  
100 feet 8214 wends installed.....45.00  
9258 RG-8X.....19c/ft

### POLICIES—MASTERCARDS, VISA or C.O.D.

All prices FOB Houston, Texas, except as noted. Prices subject to change without notice, subject to prior sale. Used gear sale price refunded if not satisfied. Call anytime to check status of your order. Texas residents add sales tax.

FOR MORE INFORMATION CALL

outside Texas  
**1-800-231-3057**  
Texas and outside U.S.  
**1-713-520-7300**

✓ 137

# ICOM R71-751-R7000\* COMPUTER INTERFACE



MEC 71α



MICROCOMPUTER ELECTRONICS CORPORATION NOW OFFERS THE M.E.C. 71α COMPUTER CONTROL INTERFACE THAT WILL CONTROL AND EXPAND THE CAPABILITY OF THE ICOM R71A.



**MAIN MENU** Control center for entire system. Showing: 24HR UTC time; radio freq. & mode; memory CH, freq, mode plus ID functions for your selection.

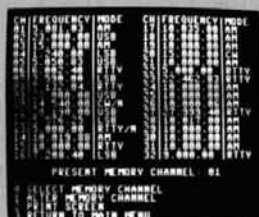

**32 CH RADIO MEMORY** Showing freq to 10 Hz, mode, filter w/n. Load/change any memory, mode, filter direct from keyboard and print command.

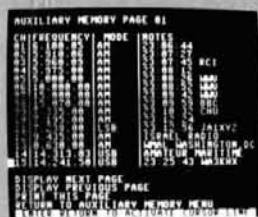

**AUXILIARY MEMORY** Showing page 1 of 47 pages each having 15 memories. Freq, mode, UTC time and room for your notes. Auto log feature allows instant logging of receiver freq, mode, time.

- **Easy to use.** No computer knowledge needed, automatic program loading. No disk or tape required (except for aux memory storage).
- **Menu driven** to aid user at each step.
- **No radio modification necessary** (ICOM EX309 — not supplied — required).
- **AUTO LOG** Allows logging of radio freq, mode and time by press of a key.
- **UNLIMITED STORAGE** via computer disk or tape (store 705 CH per disk side). Let your imagination run wild.
- **Software update.** As new software is developed MEC will make it available to owner subscribers.

- **HARD COPY** via computer printer of all memory channels.
- **KEYBOARD** memory loading.

**INTRODUCTORY PRICE**  
**\$199.95**  
 (+ \$4.00 UPS)

EX309 required but not included. Price: \$39.00  
 Dealer Inquires invited.

EEB is the exclusive distributor for Micro-computer Electronics Corp's products worldwide.

EEB is an authorized ICOM dealer and service center.

## GET ALL THE DETAILS. WRITE OR CALL EEB TODAY



- Prices & specs subject to change
- Shipping charges not included
- Returns subject to 20% restock charge
- Free catalog in USA; all others 3 IRC's

ORDER TOLL FREE 800-368-3270

Tech Info — VA orders 703-938-3350

**ELECTRONIC EQUIPMENT BANK**  
 516 Mill Street NE  
 Vienna, VA 22180 USA

# "ABSOLUTELY FREE!"



## HAMFEST<sup>©</sup> GAME \$9.95 VALUE

We will ship you our unique version **HAMFEST<sup>©</sup> 1986** board game, designed especially for Amateur Radio operators and their families "absolutely free" with your one-year "trial" subscription to the **USATVS Journal!** This unique "collectors item" includes dice, special event cards, player tokens, play money and comes with complete instructions. It even has its own protective mailing tube container!

Please add \$1.50 to offset mailing costs. Foreign orders add \$5.00 (sent surface).

**THE SPEC-COM JOURNAL<sup>™</sup>** is a "monthly" publication (10 times per year) devoted to Amateur Radio "specialized modes". Whether your interests are in FSTV, SSTV, FAX, TVRO, OSCAR, EME, RTTY, PACKET, MICROWAVE, LASER, or COMPUTERS, the Journal covers it all! Now in our 19th year (formerly A5ATV Magazine), our "Membership Services" department offers back issue and article reprints, a vast technical book library, educational video tapes and a large computer software program collection for your home computer! Why not give us a try?

USA/CANADA/MEXICO \$20.00 yr.  
 Foreign subscriptions \$30.00 (surface)



"TUNE IN THE WORLD OF SPECIALIZED COMMUNICATIONS!"

With a subscription to:

## SPEC-COM<sup>™</sup>

Amateur Radio Specialized Communication Journal

P.O. Box HR

Lowden, Iowa 52255



(319) 944-7669  
 (Membership Services)

4% Added To All Charge Card Orders

## Our Very-Hard-To-Find Components List

### CAMBIAN RF CHOKES

15μh, 22μh, 33μh, 4.7μh, 10μh ..... 1.20 ea.

### UNDERWOOD/SEMCO METAL-CLAD MICA CAPACITORS

Type J101: 5 pf, 10 pf, 15 pf, 25 pf, 30 pf, 40 pf, 60 pf, 80 pf, 100 pf, 200 pf, 250 pf, 390 pf, 470 pf ..... 1.60 ea.

Type 3HS0006: 25 pf, 30 pf, 35 pf, 40 pf, 56 pf, 68 pf, 91 pf ..... 1.60 ea.

Type J102: 1000 pf ..... 2.00 ea.

### P.C. BOARDS FOR MOTOROLA BULLETINS

AN-762, EB-27A, EB-63, AN-758, EB-67 ..... 14.00 ea.

AN-791 ..... 10.00 ea.

### FERROXUBE DEVICES

VK200 20/4B RF Choke ..... 1.20 ea. 56-590-65-3B Ferrite Bead ..... 0.20 ea.

### MISCELLANEOUS

Arco 403 Trimmer Cap 3-35 pf ..... 1.80 SBL-1 Double Balanced Mixer ..... 6.50

Sprague GYA10000 Poly Trim 2-10 pf ..... 1.10 T25-10 Toroid Core ..... 0.40

NF2-12V Aromat Relay ..... 6.25 T37-3 Toroid Core ..... 0.40

We also carry a line of VHF, UHF amplifiers and ATV equipment.  
 Call or write for our free catalog.



**CCI** Communication Concepts Inc.

2648 North Aragon Ave • Dayton, Ohio 45420 • (513) 296-1411



166

# SAVE \$7.05\* with home delivery

\*(One year newsstand cost \$30.00)

Here's my address label, enter my subscription.

- |  |         |   |
|--|---------|---|
| <input type="checkbox"/> 1 Year . . . . . 12 issues . . . . .  | \$22.95 | <input type="checkbox"/> Payment enclosed |
| <input type="checkbox"/> 2 Years . . . . . 24 issues . . . . . | \$38.95 | <input type="checkbox"/> Bill me later    |
| <input type="checkbox"/> 3 Years . . . . . 36 issues . . . . . | \$49.95 | U. S. prices only                         |

Name \_\_\_\_\_

Zip \_\_\_\_\_

State \_\_\_\_\_

Address \_\_\_\_\_

City \_\_\_\_\_

Check here if this is your renewal (attach label)

## Subscribe to **ham radio** magazine

Please allow 4-6 weeks for delivery of first issues.

**Foreign rates:** Europe, Japan and Africa, \$37.00 for one year by air forwarding service. All other countries \$31.00 for one year by surface mail.



Please  
enter my  
subscription



**BUSINESS REPLY CARD**  
First Class    Permit No. 1    Greenville, NH

Postage Will Be Paid By Addressee

**ham  
radio**  
Greenville, NH 03048

NO POSTAGE  
NECESSARY  
IF MAILED  
IN THE  
UNITED STATES



den cessation of oscillation (or a parasitic developing) at that point on the dial.

Crystal oscillators behave in a similar manner. If the crystal selector switch is changed, then the voltage can be expected to change also. If the crystal is removed, then the voltage will usually change radically.

By the way, don't remove crystals willy-nilly. In some cases, especially when the next stage is a grid-leak biased vacuum tube power amplifier, damage might occur to the equipment.

### an ambiguous case

There are three ways to stage isolate a dead radio receiver. In part I of this two-part series, we reviewed signal injection and signal tracing and in this article we discuss using a DC voltmeter to find the defective solid-state stage. But some situations are not as clear.

Consider **fig. 4**. This circuit is a simplified audio section, with only the preamplifier shown in detail. The combination of AF preamplifier and output power amplifier may be capacitor coupled (as shown here), direct coupled or in the form of a single integrated circuit housing both stages. The symptom is weak reception. All stations are heard, but at very low volume. If you read last month's article, you'll recall that this symptom generally points to the output IF amplifier, detector or audio stages; but in this case, it's the audio stage that contains the fault.

I've seen a lot of cases where the DC voltages on Q1 were normal and there seemed to be adequate signal passing through the stage regardless of whether signal injection or tracing was used. The ambiguity will show up except in the very special case where the sensitivities and impedances of the signal generator and signal tracer are matched to the particular equipment being serviced (some "radio analyst" instruments used by commercial servicers fall into this category).

In the event that this ambiguity

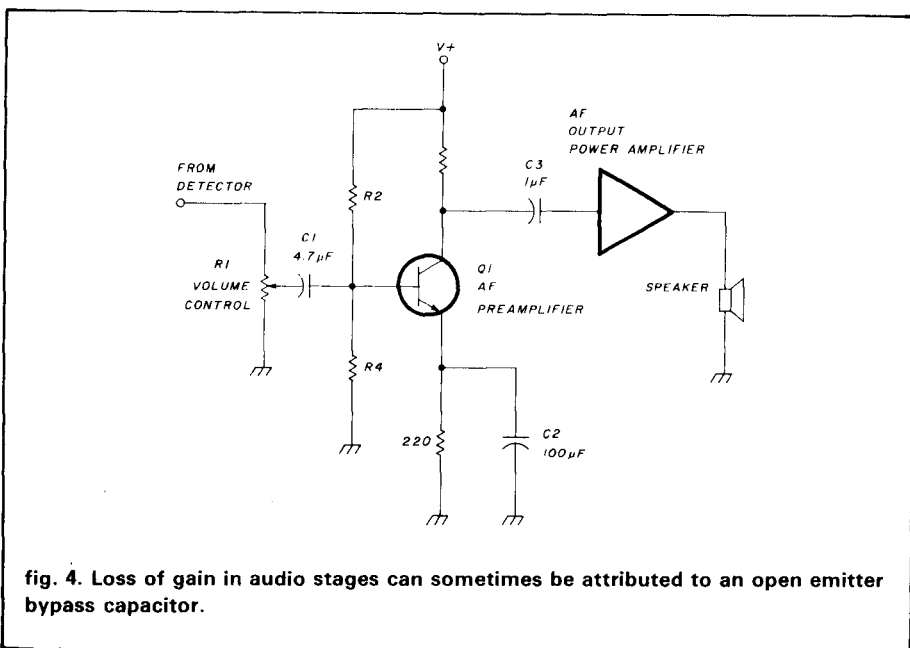

**fig. 4.** Loss of gain in audio stages can sometimes be attributed to an open emitter bypass capacitor.

shows up, jump on capacitor C2. This capacitor is used to place the emitter of Q2 at or near ground potential for AC while retaining the DC bias on the emitter. If this capacitor opens up, the gain of the stage will go down one heckuva lot without (usually) affecting the DC voltages. Turn the rig off, solder tack a replacement capacitor across C2 (the exact value isn't critical — anything  $\pm 200$  percent of the correct value will do for the test). Turn the rig on. If the output volume comes up a lot, then mark C2 for replacement.

I don't know why it is, but this problem seems to keep popping up. I've seen it in varying degrees in car radios, home radios, Amateur radios, CB radios and commercial two-way radios. It also turns up in vacuum tube equipment.

*Old Gear Restorer's Note:* If you restore an old Heath DX-60B (or other older transmitter) and find the RF output intermittent as the rig is keyed, then look to the plate circuit of the crystal oscillator. This circuit is a modified Miller oscillator, and has a slug-adjusted inductor in the plate circuit. When the rig is stored, unused for several years, the core of this coil will

change characteristics, and the oscillator will refuse to oscillate reliably. I scratched my head over two of these rigs last year and finally stumbled on the answer. While keying the rig, carefully adjust the slug until reliable operation occurs (as indicated by a light-bulb dummy load or RF wattmeter), then give it another turn or so.

Incidentally, similar circuits are used in a lot of older ham gear, both vacuum tube and solid state, HF and VHF. Anytime you have a piece of equipment with an oscillator of this type that seems to operate intermittently or unreliably, and everything else seems to check out, then consider adjusting the coil.

Normally I don't recommend "diddlestick" troubleshooting — to the extent of hollering "NEVER!" when someone suggests it. One of the few possible exceptions might be in equipment that has been unused for many years, and contains ferrite core coils in oscillator circuits. I still maintain that sudden failures in equipment that has been working should be regarded as a component failure, not as an alignment problem so in that case, leave the darned diddlestick in the toolbox!

**ham radio**

# PACKET RADIO . . .

## . . . THE FASTEST GROWING PART OF AMATEUR RADIO TODAY

is already providing high speed, error free, communications on many amateur bands for qso's, data transmission, emergency traffic, dx'ing, traffic nets, mailboxes, endless experimentation, and soon... satellite operation.

networks continue to grow, as does the number of hams who enjoy this new and exciting mode. The increasingly popular **PACKETERM IPT** is contributing to phenomenal growth in amateur packet radio by providing a full function packet terminal in a compact, portable unit...



## ALL YOU NEED FOR PACKET OPERATION IS A <sup>tm</sup>PACKETERM IPT AND YOUR RIG !

Designed for true portability, the IPT is equally at home in your ham shack or (with its optional carrying case) trekking in the country for battery powered hilltopping!

A single cable connects to your transceiver....that's all there is to it!

Use it with your base station, mobile, or with your HT on that hilltop!!!

- FEATURES:**
- \* \* 9 inch portable terminal and full function tnc combined
  - \* \* 66 commands available - the most widely used, field proven programming .
  - \* \* Built-in LSI modem ; 300 or 1200 baud, 200 or 1 kHz audio shift
  - \* \* stores setup parameters with power off - uses lithium battery
  - \* \* custom "beacon" text -- your call, qth, etc. in permanent memory
  - \* \* 74 key, full travel keyboard with 14 function keys for commands, calls, etc.
  - \* \* printer port - RS232C serial
  - \* \* optional printer, carrying case, and dc adaptor (13.8 VDC)

 **Packeterm**

Box 835, Amherst, NH 03031

(603)-673-6630

PRICES:	IPT COMPLETE	\$995
	PRINTER	\$349
	DC ADAPTOR	\$125
	TNC (BOARD ONLY)	\$275

# the offset drooper

## an improved ground plane

Reduce antenna effect  
and still achieve  
a 50-ohm  
feedpoint resistance

The original "ground plane" omnidirectional antenna was developed in the late 1930s jointly by Dr. George H. Brown, J. Epstein and R. F. Lewis, W2EBS, all of RCA Laboratories. It consists of the long-familiar configuration of a vertical quarter wave "spike" working against four resonant radials at 90 degrees to the mast. In the original version, patented in 1941, the feedpoint impedance is matched to the coaxial feedline by means of a quarter wave coaxial "Q" section. A typical Amateur adaptation is shown in **fig. 1**. In 1942 Dr. Brown patented, solely, the version shown in **fig. 2**, which has several advantages over that of **fig. 1**.

These basic "ground plane" antennas exhibited less antenna effect (surface current) on the mast and feedline than did other omnidirectional VHF antennas widely used at the time. However, the four radials at 90 degrees to the mast are somewhat "transparent" and definitely resonant. For this reason they may be considered more a part of the antenna than a virtual ground plane for the "spike." Semi-infinite ground plane characteristics would allow little radiation below zero degrees elevation. Such a pattern might be unsuited to a mountain top location or a swaying free-standing mast.

Because of the direction of current flow in the radials, the resultant radiation from the individual spikes results in good cancellation, and there is little net radiation from them. The fact that one may touch the tip of one radial with little effect on VSWR doesn't mean that the radials do a good job of simulating a large, flat conductive sheet. Because of the quarter wavelength of the radials, pinching the tip of one elevates the impedance at the opposite end and effectively isolates it. The remaining three radials simply take over, with only moderate detuning of the antenna.

The result of all this is as follows: the performance of a "90 degree" ground plane represents an improvement over several previously popular base station antennas. However, while orienting the resonant radials at 90 degrees does reduce inductive coupling to the coaxial line and mast, it doesn't effectively eliminate it. The coupling is sufficient that the resulting antenna effect may be found undesirable for some applications.

Long popular among hams for VHF and upper HF is the "droopong" ground plane, a simplified, less elegant, low-cost descendant of the Brown ground plane. Simply bending down the horizontal radials to about 45 degrees raises the radiation resistance to 50-52 ohms. This permits direct connection of the coax without use of a matching device. A more appropriate description might be "skeleton skirt dipole," because the resonant drooping radials don't do a very good job of serving as a virtual ground plane. Instead, they exhibit more inductive coupling to the feedline than do radials at 90 degrees.

Nearly 40 years ago, in the *Antenna Manual*, I pointed out that while the drooping ground plane or "drooper" is simple and works well, the configuration aggravates antenna effect. For the benefit of those not familiar with the term, *antenna effect* (transmit case) can be described briefly as follows:

*Antenna effect on a two-wire line:* refers to line radiation as a result of "common mode" current. Part of the power (energy) fed to the feedline travels on it as though the two wires were tied together and were working against ground. Usually it results from load imbalance and/or excessive coupling from one side of a balanced antenna to the line. Common mode current adds in one wire and subtracts in the other. This in-phase component of the total power fed to the line acts as though the two wires were in parallel. So it gets radiated.

*Antenna effect on a coaxial line* refers to radiation from a coaxial feedline as a result of current flowing on the outside of the outer conductor. The current often is shared with the surface of a metal mast supporting a bottom-fed vertical antenna. Usually it results from either or both of the following:

- The outer conductor of the coax is directly connected to a point on the antenna not precisely at

By Woodrow Smith, W6BCX, P.O. Box 2898,  
Anaheim, CA 92804

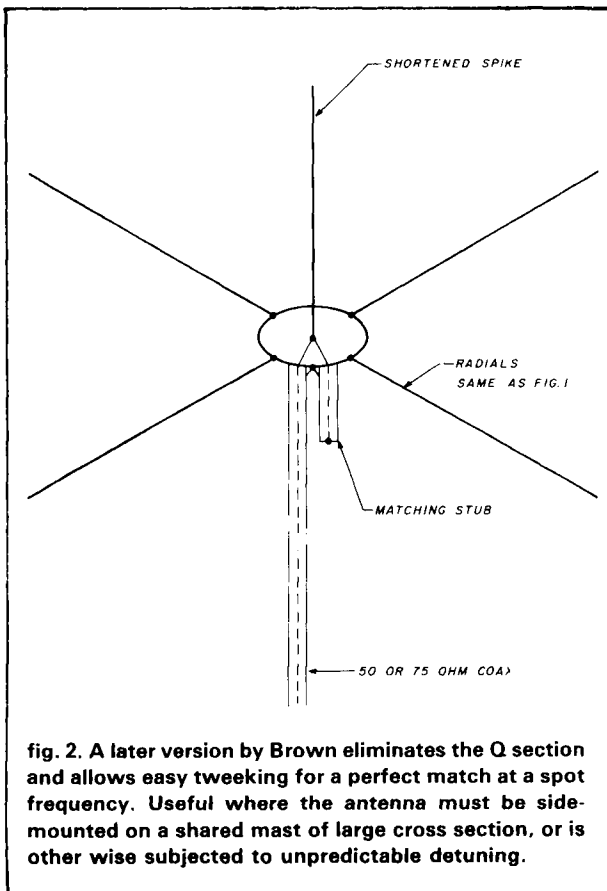
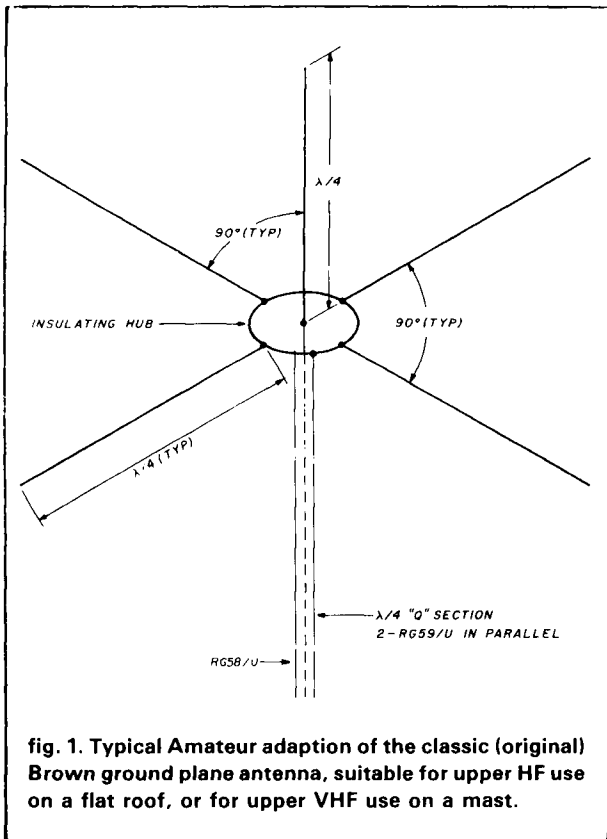

ground potential. As a result, current flows not just to the antenna, but is encouraged to flow back down the *outside* of the coax shield to a virtual ground as well. The "ground" can be a cabinet at VHF or house wiring at HF, for example.

- Excess inductive coupling exists from one half of the antenna to the outside of the coax or metal supporting mast (or both). The radials of a drooping ground plane are a case in point. If the coax is enclosed by a metal mast, spurious current flows on the surface of the mast. If the coax is draped along the outside of a metal mast, current flows on the surfaces of both and *both* radiate. To complicate things, the mast can have its own virtual ground.

### is antenna effect all that devastating?

At just what point antenna effect becomes serious enough to be concerned about is debatable. The amount of current that can be tolerated on the outside of a coax line or mast or both depends to a great extent upon the following:

On transmit, let's first consider a well elevated, vertically polarized, omnidirectional VHF antenna with a feedline many wavelengths long. What is the result of antenna effect? Normally little of the power (energy) radiated with vertical polarization from such a long feedline (and the mast) will be directed at the horizon. For this reason, little of the spurious radiation will either add to or subtract from the energy being radiated effectively towards the horizon by the antenna proper.

So at VHF the end result of antenna effect on *transmit* is primarily a waste of power. But even if as much as 20 percent of the total radiated power is radiated by the coax, mast or both and thereby wasted, the resulting 1 dB loss is hardly anything to get worked up about. This is especially true when it buys worthwhile simplicity, convenience, or economy. However, if the radiating coax passes close to a TV receiver feedline, TVI may result if the TV coax suffers from poor shielding, or if the TV twinlead feeds a poorly balanced receiver front end.

On *receive*, the situation is different. Consider a coax line running through a localized area of high ambient noise. Antenna effect can cause noise picked up by the outer conductor of the coax to travel up to the antenna proper, then back down the coax to the receiver input just like a desired signal.

### baluns vs. resonant isolators

Baluns of the type used with HF dipoles to minimize antenna effect are not suited for use with vertically polarized VHF antennas of the omnidirectional type. Instead, resonant detuning sleeves, cones, and radials are widely used as isolators or decouplers to "cool off" the mast and feedline. To what extent these produce any practical benefit in a particular installation by



reducing antenna effect often is open to question. The use of coiled coax, ferrite beads, or a ferrite sleeve to choke off or dissipate surface current on the coax does not solve the metal mast problem.

Granted, no startling increase in transmitted signal strength will be noted when a resonant isolator of some kind is added to a simple VHF drooping ground plane. But even so, suppose it were possible to achieve a big reduction in antenna effect on the drooper without adding a resonant isolator. Suppose the various resulting advantages (such as they are) could be achieved by simply altering the dimensions and the droop angle.

### **something for nothing?**

It's not only possible; it's *simple*. And there are no additional parts or materials, and without any additional manufacturing, construction, or assembly labor. Here's how: take the case of a conventional drooper that's supported by a metal mast enclosing the coax. Current is induced on the mast as a result of inductive (mutual impedance) coupling to the radials. If the coax exits the hub external to the mast (offset antenna mount), spurious current also appears on the outside of the coax.

This detrimental inductive coupling can be reduced somewhat by reducing the droop of the radials (the angle they make with the horizontal). The remainder can be compensated for by deliberately introducing a critical amount of conductive coupling of opposite phase. This is done by drastically offsetting the feedpoint from the voltage node.

The offset required for good cancellation is accomplished by simply making the radials as much as 30 percent (yes, thirty percent!) longer than the spike. Because precise cancellation is somewhat frequency-sensitive, the effectiveness will vary a bit over the 2-meter band. However, in spite of the fact that optimized coupling neutralization is less than perfect over the whole band, the practical results obtained are most worthwhile.

Offsetting the feedpoint from the voltage node raises the feedpoint resistance. On the other hand, lessening the droop angle lowers the feedpoint resistance (by lowering the radiation resistance). By proper choice of these two values, it's possible to reduce antenna effect dramatically while at the same time achieving a 50-ohm feedpoint resistance. With an offset represented by a 28-30 percent radial-to-spike length differential, a 27-29 degree droop angle provides both maximum reduction in antenna effect *and* a 50-ohm feedpoint resistance. To some extent the optimum values vary with conductor diameter, mast diameter, and hub geometry. Less important is whether the coax departs the hub inside or outside the tubular mast.

Neither the 1.5 VSWR bandwidth nor the antenna gain is noticeably degraded by drastically offsetting the feedpoint and reducing the droop of the radials. And in case you're skeptical about the horizon gain comparisons, it's true that the spike is slightly shorter on an offset drooper. Likewise, the resultant vertical component or vector of the drooping radials is a little shorter for an offset drooper than for a regular drooper. But careful measurements show this does not affect the gain significantly. Increased current throughout the antenna resulting from the lower radiation resistance (about 35 ohms) compensates. Also, power wasted by line and mast radiation is reduced to insignificance.

Out of curiosity, a check was made to see just what would happen if the feedpoint of a classic 90-degree ground plane were deliberately offset. When the resonant radials were lengthened, an arbitrary 12 percent and the spike length and matching adjustment were re-optimized, antenna effect was virtually eliminated. However, overall performance was no better than that of an offset drooper, which has the advantage of requiring no matching device. Because of the latter, no further work was done with 90 degree ground planes. It is interesting to note that when resonant radials at 90 degrees to the mast were shortened experimentally by no more than a few percent, antenna effect was markedly aggravated.

### **improvement over what?**

A check was made on drooper dimensions given in various handbooks and past magazine articles. Also, two different commercially manufactured 2-meter droopers were purchased and the dimensions measured. The effective radial length ranged from slightly longer than the spike to slightly shorter. All were series-fed at the hub without benefit of a matching device. None employed a resonant decoupler, such as an extra set of radials below the antenna oriented 90 degrees to the mast.

The reduction of antenna effect provided by drastically offsetting the feedpoint of a drooping ground plane depends, among other things, upon how bad the antenna effect is to begin with. This varies somewhat with location of the voltage node on the regular drooper used for comparison. For instance, antenna effect definitely will be worse if the radials of a regular drooper are significantly shorter than the spike, as was the case with one of the name brand antennas tested. This makes an offset drooper appear just that much better by comparison.

### **a spurious top-fed Marconi is the culprit**

The degree of improvement will also vary with the length of the coax. This is explained as follows: the



### Save \$30 on the RAMSEY 20MHz Dual Trace Oscilloscope

Unsurpassed quality at an unbeatable price, the Ramsey oscilloscope compares to others costing hundreds more. Features include a component testing circuit for resistor.

capacitor, digital circuit and diode testing • TV video sync filter • wide bandwidth & high sensitivity • internal graticule • front panel trace rotator • Z axis • high sensitivity x-y mode • regulated power supply • built-in calibrator • rock solid triggering

Was \$399.95 NOW ONLY **\$369.95** high quality hook on probes included



### NEW RAMSEY 1200 VOM MULTITESTER

Check transistors, diodes and LEDs with this professional quality meter. Other features include, decibel scale • 20K volt metering system • 3 1/2" mirrored scale • polarity switch • 20 measuring ranges • safety probes • high impact plastic case

**\$19.95** test leads and battery included



### NEW RAMSEY D-4100 COMPACT DIGITAL MULTITESTER

Compact sized reliability and accuracy. This LCD digital multitester easily fits in your pocket, you can take it anywhere. It features full overload protection • 3 1/2 digit LCD readout • recessed input jacks • safety probes • diode check function • 2000 hours battery life

**\$22.95** test leads and battery included

### NEW 35 MHz DUAL TRACE OSCILLOSCOPE



A heavy duty and accurate scope for service as well as production use. Features include • wide frequency bandwidth • optimal sensitivity • extremely bright display • delayed triggering sweep • hold off • ALT trigger • single sweep • TV sync • 5X magnification • XY or XYZ operation • HF/LF noise reduction

**3500 Dual Trace Oscilloscope \$499.95** includes 2 high quality probes

ALL OSCILLOSCOPES INCLUDE 2 PROBES

### NEW 15 MHz DUAL TRACE PORTABLE OSCILLOSCOPE



Ideal for field/bench applications, this scope can display up to 15 MHz signals. Internal battery pack allows up to 2 hours operation on a single charge. Features include • built-in battery charger • 5X horizontal magnification • high brightness CRT • front panel trace rotator • internal rechargeable battery pack

**2500 Portable Oscilloscope \$449.95** includes 2 high quality probes

### MINI-100 FREQUENCY COUNTER

Features and capabilities of counters costing twice as much • compact • high sensitivity • low current drain • very accurate • leading zero blanking • field or shop use • 1 MHz to 500 MHz range • diode protected • 7 digit display

**\$9.95** BATTERY CHARGER NICAD BATTERIES AND AC ADAPTER INCLUDED



### CT-70 7 DIGIT 525 MHz COUNTER

Lab quality at a breakthrough price. Features • 3 frequency ranges each with pre amp • dual selectable gate times • gate activity indicator • 50mV @ 150 MHz typical sensitivity • wide frequency range • 1 ppm accuracy

**\$119.95** wired includes AC adapter

CT-70 kit ..... \$99.95  
BP-4 nicad pack ..... 8.95

### CT-50 8 DIGIT 600 MHz COUNTER

**\$139.95** wired

CT-50 kit ..... \$139.95  
RA-1 receiver adapter kit ..... 14.95



### CT-90 9 DIGIT 600 MHz COUNTER

The most versatile for less than \$300. Features 3 selectable gate times • 9 digits • gate indicator • display hold • 25mV @ 150 MHz typical sensitivity • 10 MHz timebase for WWV calibration • 1 ppm accuracy

**\$149.95** wired includes AC adapter

CT-90 kit ..... \$129.95  
OY-1 0.1 PPM oven timebase ..... 59.95  
BP-4 nicad pack ..... 8.95

### CT-125 9 DIGIT 1.2 GHz COUNTER

**\$169.95** wired includes AC adapter

BP-4 nicad ..... \$8.95



### DM-700 DIGITAL MULTIMETER

Professional quality at a hobbyist price. Features include 26 different ranges and 5 functions • 3 1/2 digit 1/2 inch LED display • automatic decimal placement • automatic polarity

**\$119.95** wired includes AC adapter

DM-700 kit ..... \$99.95  
MP-1 probe set ..... 4.95



### PS-2 AUDIO MULTIPLIER

The PS-2 is handy for high resolution audio resolution measurements, multiplies up in frequency • great for PL tone measurements • multiplies by 10 or 100 • 0.01 Hz resolution & built-in signal preamp/conditioner

**\$49.95** wired

PS-2 kit ..... \$39.95



### PR-2 COUNTER PREAMP

The PR-2 is ideal for measuring weak signals from 10 to 1000 MHz • flat 25 db gain • BNC connectors • great for shifting RF • ideal receiver/TV preamp

**\$44.95** wired includes AC adapter

PR-2 kit ..... \$34.95



### PS-10B 1.5 GHz PRESCALER

Extends the range of your present counter to 1.5 GHz • 2 stage preamp • divide by 1000 circuitry • super sensitive (50 mV typical) • BNC connectors • 1 GHz in, 1 MHz out • drives any counter

**\$79.95** wired includes AC adapter

## MINI KITS—EASY TO ASSEMBLE, FUN TO USE BEGINNERS & PROS WILL HAVE A GREAT TIME WITH THESE KITS

### FM MINI MIKE

A super high performance FM wireless mike kit. Transmits a stable signal up to 300 yards with exceptional audio quality by means of its built in electret mike. Kit includes case, mike, on-off switch, antenna, battery and super instructions. This is the finest unit available.

FM-3 Kit ..... \$14.95  
FM-3 Wired and Tested ..... 19.95

### Color Organ

See music come alive! 3 different lights flicker with music. One light each for, high, mid-range and lows. Each individually adjustable and drives up to 300 W runs on 110VAC.

Complete kit, ML-1 ..... \$8.95

### Video Modulator Kit

Converts any TV to video monitor. Super stable, tunable over ch. 4-6. Runs on 3.15V. accepts vid. video signal. Best and on the market. Complete kit, VD-1 ..... \$7.95

### Led Blinky Kit

A great attention getter which alternately flashes 2 jumbo LEDs. Use for name badges, buttons, warning panel lights, anything! Runs on 3 to 15 volts. Complete kit, BL-1 ..... \$2.95

### Super Sleuth

A super sensitive amplifier which will pick up a pin drop! 15 feet! Great for monitoring baby's room or as general purpose amplifier. Full 2W rms output, runs on 6 to 15 volts, uses 8-45 ohm speaker. Complete kit, BN-9 ..... \$5.95

### CPO-1

Runs on 3-12 Vdc. 1 watt out. 1 KHz. good for CPO. Alarm, Audio Oscillator. Complete kit ..... \$2.95

### FM Wireless Mike Kit

Transmits up to 300' to any FM broadcast radio, uses any type of mike. Runs on 3 to 9V. Type FM-2 has added sensitive mike preamp stage.

FM-1 Kit ..... \$3.95  
FM-2 Kit ..... \$4.95

### Whisper Light Kit

An interesting kit, small mike picks up sounds and converts them to light. The louder the sound, the brighter the light includes: mike, controls up to 300 W runs on 110 VAC.

Complete kit, WL-1 ..... \$6.95

### Tone Decoder

A complete tone decoder on a single PC board. Features 400-5000 Hz adjustable range via 20 turn pot, voltage regulation, burst detection, FSK, etc. Can also be used as a stable tone encoder. Runs on 5 to 12 volts. Complete kit, TD-1 ..... \$5.95

### Siren Kit

Produces upward and downward wail characteristic of a police siren. 5 W peak audio output, runs on 3-15 volts, uses 3-45 ohm speaker. Complete kit, SM-3 ..... \$2.95

### 60 Hz Time Base

Runs on 5-15 VDC. Low current (25ma). 1 microsecond accuracy. TB-7 kit ..... \$5.50

### Universal Timer Kit

Provides the basic parts and PC board required to provide a source of precision timing and pulse generation. Uses 555 timer IC and includes a range of parts for most timing needs.

UT-5 Kit ..... \$5.95

### Mad Blaster Kit

Produces LOUD ear shattering and attention getting siren like sound. Can supply up to 15 watts of obnoxious audio. Runs on 6-15 VDC.

MB-1 Kit ..... \$4.95

### 30 Watt 2 mtr PWR AMP

Simple Class C power amp features 8 times power gain. 1 W in for 8 W, 2 W in for 15 W, 4 W in for 30 W. Max output of 35 W, incredible value, complete with all parts, less case and T-R relay.

PA-1, 30 W pwr amp kit ..... \$22.95

TR-1, RF sensed T-R relay kit ..... 6.95

### Power Supply Kit

Complete triple regulated power supply provides variable 6 to 18 volts at 200 ma and +5 at 1 Amp. Excellent load regulation, good filtering and small size. Less transformers, requires 6.3V (a 1 A and 24 VCT. Complete kit, PS-3LT ..... \$6.95

### ACCESSORIES FOR RAMSEY COUNTERS

- Telescopic whip antenna—BNC plug ..... \$ 8.95
- High impedance probe, light loading ..... 16.95
- Low pass probe, audio use ..... 16.95
- Direct probe, general purpose use ..... 13.95
- Tilt bail, for CT-70, 90, 125 ..... 3.95



PHONE ORDERS CALL  
**716-586-3950**  
TELEX 466735 RAMSEY CI

TERMS • satisfaction guaranteed • examine for 10 days; if not pleased, return in original form for refund • add 6% for shipping and insurance to a maximum of \$10.00 • overseas add 15% for surface mail • COD add \$2.50 (COD in USA only) • orders under \$15.00 add \$1.50 • NY residents add 7% sales tax • 90 day parts warranty on all kits • 1 year parts & labor warranty on all wired units.



RAMSEY ELECTRONICS, INC.  
2575 Baird Rd.  
Penfield, N.Y. 14626

outside of the coax shield will do its best to act like a "harmonic Marconi" fed at the top instead of the bottom. Just how effective (and therefore how objectionable) this is will depend to a great extent upon the electrical length of the coax shield in wavelengths from "virtual ground" to the point of attachment to the radials.

Unfortunately, with 40 feet of coax, QSY from 144 to 148 MHz can change the electrical length of the shield substantially. This in turn affects the feedpoint impedance of the spurious "upside down harmonic Marconi." The variation can affect the amount of line radiation by 10 dB or more in the case of a conventional drooper. Things get even more involved when comparing an offset drooper to a regular drooper for antenna effect simply by swapping them at the end of the same feedline. The radials of a 2-meter offset drooper are longer than a quarter wave and their impedance to ground at their feedpoint therefore is affected. This was taken into account when designing the antenna and making comparison measurements.

### the test set-up

For reference, a 2-meter drooper with optimized offset feed was constructed with four radials 30 percent longer than the spike and having a droop angle of 28 degrees. For starters for those who might like to experiment, the 1/8 inch diameter spike measured 18 3/8 inches and the 3/32 inch diameter radials 24 inches, all of brass welding rod. Size and configuration of the hub will affect the lengths, especially that of the spike. Note that while the spike of an offset drooper is only slightly shorter than normal, the radials are much longer. The result is that the overall length of the spike plus a radial is nearly 10 percent longer than for a conventional drooper. This involves the integral coupling neutralization and impedance transformation process, and a rigorous explanation is not within the scope of this article.

The offset drooper reference antenna just described was compared to four different conventional 2-meter droopers for antenna effect, 1.5:1 VSWR bandwidth, and field strength at zero elevation angle. One of the conventional droopers was constructed to dimensions specified in a magazine article. Two were dissimilar name brand units. None employed a detuning sleeve, cone, or extra set of radials. Measurements were taken near 144, 146, and 148 MHz with four feedline lengths differing by 1/8 wavelength.

Tests were first run with the coax leaving the hub contained within a 3/4 inch O.D. mast for the first 5 feet. The tests then were repeated with the hubs offset from the top of the 5 foot upper mast section. With the hubs offset, the coax was brought down snugly against the outside of the mast for its entire length.

Next, the hub was mounted concentrically atop a 12-foot section of aluminum tubing strapped to a steel vent pipe, with the coax brought down inside the tubing. While these changes did cause the readings to change, the overall improvement exhibited by the offset drooper did not change significantly. The coax employed was RG/8X-8M 0.25 inches OD, 52 ohm.

### test results

A spurious RF current sniffer was improvised to quantify the amount of improvement exhibited by the offset drooper. The sniffer was provided with a plastic spacing fixture that allowed choice of two spacings in order to increase the useful range. It was checked for directional effect (by reversing it) and the directivity was found to be negligible. Relative calibration in dB was accomplished by simply varying the measured power fed to a leaky dummy load which was space-coupled to the sniffer.

The reduction in antenna effect when using the offset drooper exceeded 11 dB for three of the comparison antennas tested. The improvement obtained over the fourth regular drooper (the one with the longest radials) measured 10 dB. The greatest improvement was observed when the offset drooper was compared to the regular drooper having the shortest radials (about 5 percent shorter than the spike). The improvement figures reflect those obtained or exceeded with the worst case combination of frequency, line length, and mast and feedline configuration.

This article is not intended to show the reader how to build something exactly like the author's, but instead to explain a simple method of improving the performance of the venerable drooping ground plane. Just make the spike a little shorter, the radials a lot longer and bend the radials up a bit. It is applicable to modification of existing antennas as well as to new construction. To approach the maximum possible improvement, all you need is a VSWR meter. Just make the radials 30 percent longer than the spike and droop them 28 degrees (or as close as you can). Optimum length for the spike is usually about 6 percent shorter than for a regular drooper that uses similar hub and element diameter.

If this doesn't result in equal VSWR at the band edges, the spike is too long or too short. Once the radial length and droop are optimized, the center frequency can be fudged about 1 percent just by trimming the spike.

The reader will notice that no VSWR numbers are given for an optimum offset drooper. The reason for this is that a conventional drooper with bad antenna effect can give specious VSWR readings, making any offset drooper comparisons meaningless. The deceptive readings obtained with a standard drooper will change with coax and mast lengths, and the readings

# PORTABLE ANTENNA

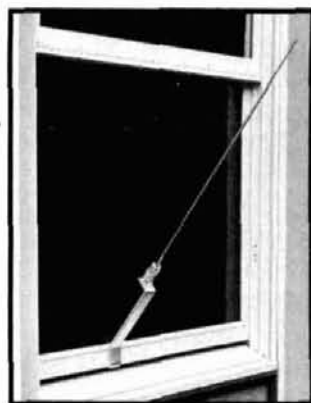

**MODEL AP-10**

Designed for  
APARTMENTS  
MOTELS  
VACATIONS

**PRICE**

**\$46<sup>75</sup>**

Add \$3.00  
Shipping and Handling

Quick Simple Installation. Operates on 2, 6, 10, 15, 20, 30 and 40 meters. All coils supplied. Only 22-1/2 inches long. Weighs less than 2 lbs. Supplied with 10 ft. RG 58 coax and counter poise. Whip extends to 57 inches. Handles up to 300 watts.

VSWR—1.1:1 when tuned

Write for more details and other B&W products

ALL OUR PRODUCTS MADE IN USA



**BARKER & WILLIAMSON**

Quality Communication Products Since 1932

At your Distributors. Write or Call.

10 Canal Street, Bristol PA 19007

(215) 788-5581



can be considerably better (or worse) than the true antenna VSWR. To a lesser extent this applies also to a classic 90 degree ground plane. But with an optimized offset drooper, readings will change little with line and mast lengths (except as reduced by line attenuation), and can be relied upon. The true VSWR of a properly optimized 2-meter offset drooper will approach 1.0:1 over much of the band, and be found very low at the band edges.

## so why not?

In closing, I hope the reader accepts the fact that while a bad case of antenna effect on a VHF drooper isn't necessarily disastrous, minimizing it certainly can't hurt. It's easy to do and all it can do is good — so why not?

## references

1. *Ground Plane Antenna*, U.S. Patent 2,234,333, issued March 11, 1941, to G.H. Brown, J. Epstein, and R.F. Lewis of RCA Laboratories.
2. *Improved Ground Plane Antenna*, U.S. Patent 2,275,342, issued March 3, 1942, to G.H. Brown.
3. Woodrow Smith, *The Antenna Manual*, Editors and Engineers, Ltd, Santa Barbara, California, 1948.

## bibliography

Vance, Harold C., Sr., K2FF, "The Ground Plane Antenna: Its History and Development," *ham radio*, January 1977, page 26.

**ham radio**

# MADISON

Electronics Supply, Inc.  
3621 Fannin St. • Houston, Texas 77004

# BIRD

## STOCK ITEMS CALL

✓ 138

Power Range	Frequency Bands (MHz)					
	2-30	25-60	50-125	100-250	200-500	400-1000
3 watts	—	5A	5B	3C	3D	3E
10 watts	—	10A	10B	10C	10D	10E
25 watts	—	25A	25B	25C	25D	25E
50 watts	50H	50A	50B	50C	50D	50E
100 watts	100H	100A	100B	100C	100D	100E
250 watts	250H	250A	250B	250C	250D	250E
500 watts	500H	500A	500B	500C	500D	500E
1000 watts	1000H	1000A	1000B	1000C	1000D	1000E
2500 watts	2500H	—	—	—	—	—
5000 watts	5000H	—	—	—	—	—

outside Texas

**1-800-231-3057**

Texas and outside U.S.

**1-713-520-7300**

# WACOM DUPLEXERS

Our Exclusive Bandpass-Reject Duplexers  
With Our Patented

**B<sub>p</sub>B<sub>r</sub> CIRCUIT<sup>®</sup> FILTERS**

... provides superior performance, especially at close frequency separation.

Models available for all commercial and ham bands within the frequency range of 40 to 960 MHz.

**TELEPHONE  
817/848-4435**



**WACOM  
PRODUCTS, INC.**

P.O. BOX 21145 • WACO, TEXAS 76702 • 817/848-4435

This publication is  
available in microform  
from University  
Microfilms  
International.



Please send information about these titles:

\_\_\_\_\_

Name \_\_\_\_\_

Company/Institution \_\_\_\_\_

Address \_\_\_\_\_

City \_\_\_\_\_

State \_\_\_\_\_ Zip \_\_\_\_\_

Phone ( ) \_\_\_\_\_

Call toll-free 800-521-3044. In Michigan, Alaska and Hawaii call collect 313-761-4700. Or mail inquiry to: University Microfilms International, 300 North Zeeb Road, Ann Arbor, MI 48106.



# TAPR TNC-2 IS NOW PAC-COMM TNC-200

- Official TAPR TNC-2 design
- World - standard AX.25 Version 2 protocol
- Top quality components throughout
- Full duplex hardware HDLC
- Wired & tested, full kit, semi-kit, bare board
- Five terminal data rates up to 9600 baud
- Real time clock for date-time stamps
- Expanded to 16K RAM, 32K ROM
- Latest multiconnect software
- Five LED status indicators
- Level 3 networking compatibility
- Low-power CMOS draws 100ma typical

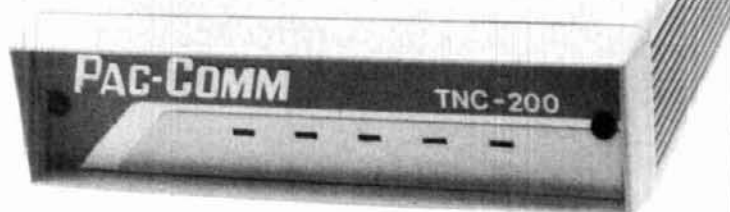

Discount 10% for orders of five or more TNC-200s

	CMOS	NMOS
Assembled/Tested	\$219.95	199.95
Full Kit	169.95	154.95
Full Kit Less Cabinet	144.95	129.95
Partial Kit	84.95	79.95

Bare Board 39.95  
Cabinet & End Plates 29.95



Macintosh Owners: MACPACKET / TNC200term gives pull-down menus, split screens, file transfers, automatic routing and more !! \$69.95 (39.95 through January 31st)

**ORDER TOLL FREE 800-835-2246 ext. 115** (Kansas 800-362-2421 ext. 115)  
(No COD) **Information 813-689-3523** Florida addresses add 5%

**PAC-COMM PACKET RADIO SYSTEMS, INC.**

✓ 125

4040 W. Kennedy Blvd, Tampa, FL 33609 Intl TELEX 6502881526 WUI

## Unadilla Amateur Antenna Baluns

For 20 years, preferred by Amateur, Commercial and Military Operators  
First with built-in lightning arrester-minimizes TVI, maximizes power handling



**W2AU 1:1 & 4:1**  
Only \$17.95, UPS  
shipping & tax included



**W2DU-HF**  
Only \$19.95, UPS  
shipping & tax included



**W2DU-VHF**  
Only \$19.95, UPS  
shipping & tax included

### W2AU Broadband Ferrite Core Baluns

For medium power (1000 watts RF min.) and broadband operation 3-40 MHz.

#### W2AU 1:1

- \* 50 to 50 or 75 to 75 ohms
- \* For dipoles, V's, beams, quads

#### W2AU 4:1

- \* 200 to 50 or 300 to 75 ohms
- \* For high impedance antennas such as folded dipoles

### W2DU Non-Ferrite Very High Power Baluns

#### W2DU-HF (High Power)

- \* 1.8-30 MHz
- \* 3000-9000 watts with 1:1 antenna SWR
- \* 1500-5000 watts with 2:1 antenna SWR

#### W2DU-VHF (High Power and Extended Range)

- \* 30-300 MHz
- \* 2000-4000 watts with 1:1 antenna SWR
- \* 1200-2400 watts with 2:1 antenna SWR

### BONUS!

Free  
With  
Your  
Order



### The Dandy Dipole

Quickly design and construct any of over 180 multi-band dipole variations, using traps. Wiring tables are included to take away the guesswork. Also includes dozens of practical details.

### At your local dealer If not order direct

- Send free catalog PC/84  
 W2AU 1:1 &  W2AU 4:1 ..... \$17.95 ea.  
 W2DU-HF &  W2DU-VHF ..... \$19.95 ea.  
 Total Order ..... \$ \_\_\_\_\_  
 Tax & UPS Shipping Included

Name \_\_\_\_\_

Address \_\_\_\_\_

City \_\_\_\_\_ State \_\_\_\_\_ Zip \_\_\_\_\_

Phone ( ) \_\_\_\_\_

- AmEx  VISA  Mastercard  
 Card # \_\_\_\_\_  
 Valid (AmEx only) \_\_\_\_\_  
 Expires \_\_\_\_\_

Check  Money Order

To ORDER or request free full line catalog of baluns, antenna relays and antenna traps, call

**1-800-523-0027**

**24 HOURS—7 DAYS A WEEK!**

NY/HI/AK/CAN residents please use coupon or call collect 315-437-3953, 8-5 EST

1 week delivery for credit card  
2 weeks for personal check.

**60 DAY MONEY BACK GUARANTEE**

Unadilla/Reyco/InLine

Division of Microwave Filter Company, Inc.  
6743 Kinne Street, E. Syracuse, N.Y. 13057



**★ QUALITY PARTS ★ DISCOUNT PRICES ★ FAST SHIPPING!**

# ALL ELECTRONICS CORP.

SEND FOR  
**FREE**  
FALL 1985 CATALOG...  
48 PAGES!

### EDGE CONNECTORS

ALL ARE 1.56" SPACING.

- 22/44 EDGE CONNECTOR  
PC style \$2.00 each  
10 for \$18.00
- 22/44 EDGE CONNECTOR  
solder lug style \$2.50 each
- 28/56 EDGE CONNECTOR  
PC style \$2.50 each  
10 for \$22.00
- 38/72 EDGE CONNECTOR  
PC style \$3.00 each
- 43/86 EDGE CONNECTOR  
PC style \$4.50 each

- ### TRANSISTORS
- |           |              |
|-----------|--------------|
| 2N706     | 4 for \$1.00 |
| 2N2222A   | 3 for \$1.00 |
| PN2222A   | 4 for \$1.00 |
| 2N2904    | 3 for \$1.00 |
| 2N2904    | 3 for \$1.00 |
| 2N2905    | 3 for \$1.00 |
| MJ2955    | \$1.50       |
| 2N3055    | \$1.00       |
| PMD 10K40 | \$1.00       |
| TIP 121   | 75¢          |
| TIP 125   | 75¢          |

- ### \*SPECIAL PRICE\* TRANSISTOR
- PN3569 TO 92 N.P.N. plastic transistor  
100 for \$8.00  
1000 for \$60.00  
LARGE QUANTITIES AVAILABLE

- ### TRANSFORMERS
- 120 volt primaries
- |                     |         |
|---------------------|---------|
| 5.6 volts @ 750 ma. | \$3.00  |
| 6 volts @ 150 ma.   | \$1.25  |
| 12 v.c.t. @ 200 ma. | \$2.00  |
| 18 volts @ 650 ma.  | \$3.50  |
| 18 volts @ 1 amp    | \$4.50  |
| 24 v.c.t. @ 200 ma. | \$2.50  |
| 24 v.c.t. @ 400 ma. | \$3.00  |
| 28 v.c.t. @ 15 amps | \$20.00 |
| 30 v.c.t. @ 2 amps  | \$5.00  |

- ### WALL TRANSFORMERS
- all plug directly into 120 vac outlet
- |                             |        |
|-----------------------------|--------|
| 4 VDC @ 70 ma.              | \$2.00 |
| 6 VAC @ 500 ma.             | \$3.50 |
| 6 VDC @ 750 ma.             | \$6.00 |
| 9 VDC @ 500 ma.             | \$5.00 |
| 12.5 VAC @ 265 ma.          | \$3.00 |
| 24 VAC @ 250 ma.            | \$3.00 |
| MULTI-VOLTAGE @ 500 ma.     | \$7.50 |
| 3, 4 1/2, 6, 7, 9 or 12 VDC |        |

- ### MINI-BOX
- Pomona #2104
- Heavy-duty black phenolic project box with cover and screws 2 3/8" X 1 1/2" X 1 1/2"
- \$1.00 EACH

### SOUND AND VIDEO MODULATOR FOR T.I. COMPUTER

T1 # UM1381-1 Designed for use with T1 computers. Can be used with video sources. Built-in A/B switch. Channel 3 or 4 selection switch. Operate on 12 vdc. Hook-up diagram included.

\$10.00 EACH

### SLIM LINE COOLING FAN



Err # 98XM182 low noise fan. Measures 3 3/4" square x 1" deep. 21 cfm. 23 db. 1700 rpm

SPECIAL PRICE ... \$12.50 each

### 2K 10 TURN MULTI-TURN POT

SPECTROL #MOD 534-7161

\$5.00 EACH

### SOLID STATE BUZZER

Star # SMB-06L  
6 vdc  
TTL compatible  
\$1.00 each  
10 for \$9.00

### ± 12 Vdc or 24Vdc POWER SUPPLY

DELTRON MODEL QD12/15-1.7 Dual plus and minus 12Vdc open frame power supply. Can be used as 24Vdc @ 1.5 amp. INPUT: either 115 Vac or 230 Vac. Fully regulated computer grade supply. 7" x 4 3/4" x 2 3/4"

\$12.50 each 10 for \$110.00

- ### \*DECEMBER\* \*SPECIALS\*
- ALL 1/4 WATT RESISTORS  
1000 pcs of one value \$7.50
- ALL 1/2 WATT RESISTORS  
1000 pcs of one value \$9.50

### 8" P.A. SPEAKER

C.T.S. Model 8B3079 \$5.00 each

8 ohms coil  
3 0 oz ferrite magnet  
Typical response range  
100 - 10,000 Hz  
Power rating 15 watts max  
Drilled to mount line matching transformers

CASE OF 8 SPEAKERS \$32.00

### LINE CORDS

TWO WIRE

- 6' 18/2 SPT-1 flat 3 for \$1.00
- 6' 18/2 SPT-2 flat
- 6' 16/2 SJT round \$1.25 each

THREE WIRE

- 6' 18/3 flat \$1.50 each
- 8' 18/3 round \$2.00 each
- 8' 16/3 round \$4.00 each

### \*SPECIAL PRICE\* DUAL L.E.D. DISPLAYS

560 high, 7 segment L.E.D. read-outs. Mount in 24 pin DIP sockets

MAN-6640 orange, c.c. 75¢ each  
FND-5148 red, c.c. 75¢ each  
DL-527 red, c.c. 75¢ each

### CASSETTE MECHANISM

New stereo cassette mechanism. Includes record/playback and erase heads. 2-12VDC motors. Drive belts. Pulleys. 3-12VDC solenoids. Pinch wheels and other mechanical parts. These parts used on other current model decks would cost several times our selling price if purchased separately. Build your own audio or data recorder or use for spare parts. 5 1/4" X 3 1/2" X 3 1/2"

\$7.50 EACH 2 FOR \$12.50

- ### D STYLE CONNECTORS
- DB25 PLUS 10 for \$11.00  
100 for \$100.00
- DB25 SOCKET 10 for \$12.50  
100 for \$110.00

### COMPUTER GRADE CAPACITORS

2,000 mfd. 200 VDC  
1 1/4" DIA. x 5" HIGH \$2.00

3,600 mfd. 40 VDC  
1 1/4" DIA. x 3 1/4" HIGH \$1.00

6,400 mfd. 60 VDC  
1 1/4" DIA. x 4 1/4" HIGH \$2.50

9,700 mfd. 50 VDC  
1 1/4" DIA. x 4 1/2" HIGH \$3.00

31,000 mfd. 15 VDC  
1 1/4" DIA. x 4" HIGH \$2.50

72,000 mfd. 15 VDC  
2" DIA. x 4 1/4" HIGH \$3.50

185,000 mfd. 6 VDC  
2 1/2" DIA. x 4 1/2" HIGH \$1.50

### RELAYS

#### 10 AMP SOLID STATE

CONTROL 3 32 vdc  
LOAD: 140 vac 10 amp  
SIZE 2 1/2" x 1 1/2" x 1 1/2"

\$9.50 EACH 10 FOR \$90.00

#### ULTRA-MINIATURE 5 VDC RELAY

Fujitsu # FBR211NED005M20  
High sensitivity  
COIL: 120 ohms  
CONTACTS: 1 amp  
Mounts in 14 pin DIP socket

\$1.25 each  
10 for \$10.00

#### MINIATURE 6 VDC RELAY

Aromat # RSD-6V  
Super Small  
S.P.D. J. relay  
Gold coil  
contact rated  
1 amp @ 30 vdc. Highly sensitive.  
TTL direct drive possible. 120 ohm coil.  
Operate from 4.3 - 6 vdc  
COIL: 120 ohms \$1.50 each  
17 1/2" x 1 1/2" x 1 1/2" 10 for \$13.50

### 3 1/2" SPEAKER

8 ohm impedance. Full range speaker. 8 oz magnet. 4 diagonal mounting centers

\$2.50 each 10 for \$20.00

### SPRING LEVER TERMINALS

Two color coded terminals on a sturdy 2 3/4" x 3 3/4" bakelite plate

Great for speaker enclosures or power supplies

75¢ EACH 10 FOR \$7.00

### CASSETTE MIKE

Dynamic cassette mike with 3.5mm plug and on/off switch.

\$1.50 EACH 10 FOR \$13.50

### TI SWITCHING POWER SUPPLY

Compact, well-regulated switching power supply designed to power Texas Instruments computer equipment

INPUT 14 - 25 vac @ 1 amp  
OUTPUT - 12 vdc @ 350 ma.  
- 5 vdc @ 1.2 amp  
- 5 vdc @ 200 ma.

SIZE 4 1/4" x 4 1/4" x 1 1/4" high

\$5.00 each

### 13 VDC RELAY

VDCS RELAY S.P.N.C  
10 amp @ 120 vac  
Energize coil to open contact  
COIL: 13 vdc 650 ohms

SPECIAL PRICE \$1.00 each

### MINIATURE TOGGLE SWITCHES

ALL ARE RATED 5 AMPS @ 125 VAC

S.P.D.T. (on-on) PC style non-threaded bushing 75¢ each 10 for \$7.00

S.P.D.T. (on-on) Solder lug terminals \$1.00 each 10 for \$9.00 100 for \$80.00

S.P.D.T. (on-off-on) Solder lug terminals \$1.00 each 10 for \$9.00 100 for \$80.00

S.P.D.T. (on-off-on) PC style non-threaded bushing 75¢ each 10 for \$7.00

S.P.D.T. (on-on) PC lugs threaded bushing \$1.00 each 10 for \$9.00 100 for \$80.00

D.P.D.T. (on-on) Solder lug terminals \$2.00 each 10 for \$19.00 100 for \$180.00

### TI SWITCHING POWER SUPPLY

Compact, well-regulated switching power supply designed to power Texas Instruments computer equipment

INPUT 14 - 25 vac @ 1 amp  
OUTPUT - 12 vdc @ 350 ma.  
- 5 vdc @ 1.2 amp  
- 5 vdc @ 200 ma.

SIZE 4 1/4" x 4 1/4" x 1 1/4" high

\$5.00 each

### TWIST-LOCK CONNECTOR

Same as Switchcraft #12CL5M.  
5 conductor in-line plug and chassis mount jack. Twist-lock style

\$2.50/SET

### ROTARY ACTION MICRO

OMRON #C 563-C41  
Clockwise act on micro used in coin operated mechanisms and low torque operations

RATED: 5 amps @ 125 Vac  
\$1.25 each 10 for \$11.00  
LARGE QUANTITIES AVAILABLE

### 4PDT RELAY

14 pin KH style  
3 amp contacts  
USED but fully tested \$1.70 each  
Specify coil voltage desired  
Either 24 vdc or 120 vac

LARGE QUANTITIES AVAILABLE

SOCKETS FOR KH RELAY 75¢ each

### STANDARD JUMBO DIFFUSED T 1 1/2

RED 10 for \$1.50  
100 for \$13.00

GREEN 10 for \$2.00  
100 for \$17.00

YELLOW 10 for \$2.00  
100 for \$17.00

### D.P.S.T. LIGHTED ROCKER SWITCH

115 vac lighted rocker. snap mounts in 3/8" x 1 1/8" hole. Orange lens. 16 amp contact

\$1.50

### 13.8 VDC REGULATED POWER SUPPLY

These are solid state, fully regulated 13.8 vdc power supplies. Both feature 100% solid state construction, fuse protection, and L.E.D. power indicator. U.L. listed

2 amp constant, 4 amp surge \$18.00 each

3 amp constant, 5 amp surge \$25.00 each

### 7 CONDUCTOR RIBBON CABLE

Spectra strip red marker strip. 28 ga. stranded wire.

\$5.00 per 100 roll

### SNAP ACTION SWITCH

Cherry elect. #E-21 N.O. or N.C.  
0.1A contacts. Suitable for alarms and other low energy circuits

1 1/4" lever

45¢ EACH 10 FOR \$4.20

### FLASHER LED

5 volt operation  
red jumbo T 1 1/2 size \$1.00 each

### BI-POLAR

jumbo T 1 1/2 size  
2 for \$1.70

### MINI-PUSH BUTTON

S.P.S.T. momentary normally open 1/8" bushing  
Red button  
35¢ each  
10 for \$3.00

### D.C. CONVERTER

Designed to provide a steady 5 vdc @ 240 ma. from a battery supply of 3.5 to 6.25 volts

2 1/8" x 1 1/8" x 1 1/8"

\$1.50 each

### SNAP ACTION SWITCH

Cherry elect. #E-21 N.O. or N.C.  
0.1A contacts. Suitable for alarms and other low energy circuits

1 1/4" lever

45¢ EACH 10 FOR \$4.20

### LED HOLDERS

Two piece holder for jumbo LED

10 for 65¢ 100 for \$5.00

### CLEAR CLIPLITE LED HOLDER

Make LED a fancy indicator. Clear

4 for \$1.00

### KEY ASSEMBLY

5 KEY \$1.00 each  
contains 5 single-pole normally open switches. Measures 3/4" long

6 KEY \$1.25 each  
contains 6 single-pole normally open switches. Measures 4 1/4" long

### METAL OXIDE VARISTOR

Popular GE # 130LA10A varistor 3/8" diameter

\$1.25 each

## reflector antennas: part 1

The subject of reflector antennas in general and those of the parabolic dish type in particular generates lots of correspondence and requests for information. I never knew that any single VHF/UHF/SHF antenna could be so much on everyone's mind — especially since so much material has already been written on the subject. Confusion seems to reign.

Since it began, this column has concentrated on providing solid groundwork in the lower frequencies; limits of time and space have not allowed discussion of more narrowly-defined topics such as specific types of antennas. But with last month's column, we launched a discussion of the microwave bands<sup>1</sup> so this would seem to be an appropriate time to address the subject of reflector antennas since they're so often used at UHF and microwave frequencies.

This discussion will be divided into two parts. Part I — this month's column — addresses the electrical aspects of reflector antenna design, including gain and specific parameters of the parabolic antenna. Part II — next month's column — will cover feed systems and the mechanical aspects of parabolic antenna design. With Parts I and II in hand, you should have all the required material and references necessary to design and build a first-class parabolic antenna.

## reflector antenna types

Before discussing the parabolic dish, it should be interesting to review some of the more common types of reflector antennas. They include, but are not limited to, the cylindrical parabola, parabolic dish, corner reflector, backfire, spherical dish, and dual reflector types of antennas.

The *cylindrical parabola* (fig. 1A), believed to be the first RF-type of reflector antenna, was used by Heinrich Hertz in 1888! He illuminated a reflector with a spark-gap at about 66 cm (445 MHz) in an attempt to prove the existence of electromagnetic waves, which had been theoretically predicted by James Clerk Maxwell.<sup>2</sup> For best performance, the cylindrical parabola requires a line feed. (Thus was born the field of microwave optics.) An Amateur cylindrical parabola is described in reference 3.

Reflector antennas were soon eclipsed by the search for DX on the HF (high frequency) bands by Marconi and others. Thus it wasn't until the 1930s that serious work on reflector antennas got under way, primarily through the efforts of Grote Reber, ex W9GFZ, in his radioastronomy experiments. Reber used the parabolic dish type of antenna shown in fig. 1B. Properly designed, it focuses all the energy at a common point, which greatly simplifies the feed system. Hence it is often referred to as a prime focus-fed antenna.

The *corner reflector*, as depicted in fig. 1C, was invented by Dr. John

Kraus, W8JK, in 1940.<sup>4</sup> However, it is limited to gains of up to about 15 to 20 dBi and is quite large relative to the gain delivered.

The *backfire antenna* was invented by Dr. Herman Ehrenspeck in 1958.<sup>5</sup> He discovered that if a Yagi antenna were aimed into a special reflector system and the Yagi structure properly re-tuned, its gain could be increased by 3 to 5 dB (fig. 1D). However, the backfire antenna never gained popularity because it required a large reflector with a special stepped surface.

Later Dr. Ehrenspeck designed the *short backfire antenna* shown in fig. 1E.<sup>6</sup> It's smaller and simpler, but its gain is lower (16 dBi is typical). However, it has gained popularity with the military, especially for portable VHF/UHF satellite operation.

At first glance, the *spherical reflector* looks very much like a parabolic dish. But it has a different reflector profile and is very difficult to feed because the energy is not focused on a common point, as in the parabolic dish. Instead, the energy is present along a line, and a special phased line-source feed is required to properly phase the energy.

Because of its shape, the spherical reflector beam can be partially aimed by simply moving the feed system. This allows the beam to be steered off boresight by up to several times the antenna beamwidth, with little or no performance degradation. Hence the spherical reflector antenna is often used in large structures where the reflector is stationary.

## Introducing the BUTTERFLY™ Beam from Butternut!

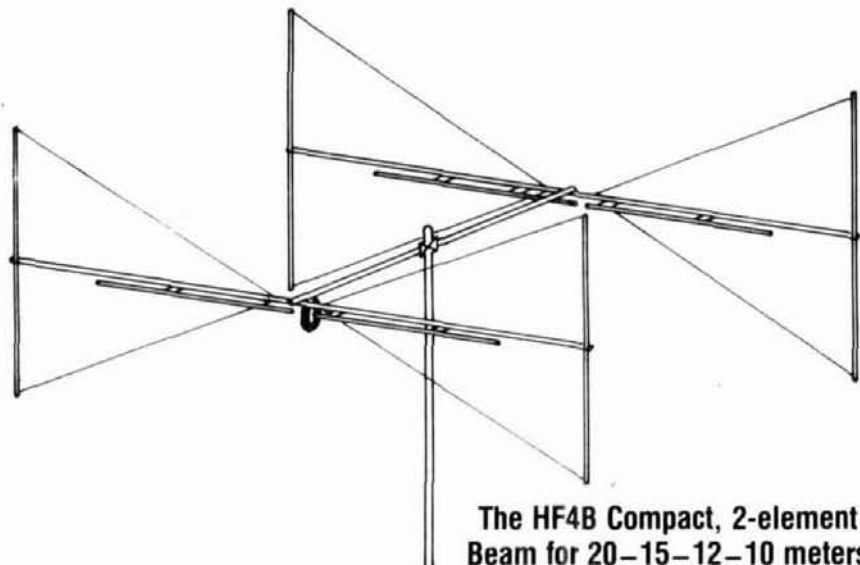

The HF4B Compact, 2-element  
Beam for 20-15-12-10 meters

### Compact Size

The HF4B's 12½-foot elements and 6-foot boom are ideal for home-station use and for weekend retreats, condos, apartments and other places where oversized beams are prohibited. Its light weight (17 pounds) means it can be turned with a tv rotator, yet it is robustly constructed in the best tradition of our world-famous Butternut verticals.

See your authorized  
Butternut dealer

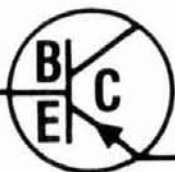

## BUTTERNUT ELECTRONICS CO.

405 East Market Street  
Lockhart, Texas 78644

Please send all reader inquiries direct.

### Performance

The HF4B BUTTERFLY™ has not sacrificed performance for compactness. Its unique design with fanned elements and L-C circuits avoids use of power-robbing traps yet provided high-efficiency operating on all bands. The BUTTERFLY™ outperforms anything in its class.

The HF4B offers an SWR of 1.5:1 or less at resonance. Its 2:1 bandwidth is 200 kHz on 20 meters, 450 kHz on 15, 1.7 MHz on 10, and across the entire 12 meter band. And it will handle the legal power limits both CW & SSB. Gain is at least 3 dB on 20, 4.5 dB on 15 and 5 dB on 10 & 12 meters. Front-to-back is up to 18 dB on 10, 12 and 20m, and up to 15 dB on 15m.

# MISSOURI RADIO CENTER

## ANTENNA SALE

### HYGAIN TOWERS

HG37SS .....	C
HG52SS .....	A
HG54HD .....	L
HG70HD .....	L

### CUSHCRAFT

A3 .....	205.00
A4 .....	275.00
R3 .....	255.00
40-CD2 .....	275.00
AV5 .....	96.00
32-19 .....	89.00
215WB .....	75.00
ARX2B .....	35.00
A144-11 .....	46.00
A144-20T .....	69.00
424B .....	75.00
AOP-1 .....	137.00

### KLM

KT34A .....	329.00
KT34XA .....	475.00
432-20LBX .....	64.00
432-30LBX .....	90.00
435-18C .....	109.00
435-40C .....	149.00
2M-13LBA .....	77.00
2M-14C .....	85.00
2M-16LBX .....	89.00
2M-22C .....	115.00

### HYGAIN

TH3JR .....	
TH7 .....	
EX 14 .....	C
14AVQ .....	A
18AVT .....	L
V2 .....	L
V3 .....	
V4 .....	

### HUSTLER

25% OFF ALL MOBILE	
6BTV .....	125.00

### AEA

144SR .....	42.00
-------------	-------

### BUTTERNUT

HF6V .....	110.00
HF2V .....	110.00
RG213U .....	\$ .26/foot

### ROTATORS

CD45 .....	C
HAM IV .....	A
T2X .....	L
AVANTI 2M .....	29.95
HI-Q BALUN .....	9.95

### KENPRO

KR400 .....	119.00
KR500 .....	149.00
KR600 .....	199.00
KR5400 .....	249.00

## CADDELL COIL CORP.

35 Main Street  
Poultney, VT 05764  
802-287-4055

### BALUNS

Get POWER to your antenna! Our Baluns are already wound and ready for installation in your transmatch or you may enclose them in a weatherproof box and connect them directly at the antenna. They are designed for 3-30 MHz operation. (See ARRL Handbook pages 19-9 or 6-20 for construction details.)

100 Watt (4:1, 6:1, 9:1, or 1:1 Impedance — Select one)	\$ 9.50
Universal Transmatch 1 KW (4:1 Impedance)	13.50
Universal Transmatch 2 KW (4:1 Impedance)	16.00
Universal Transmatch 1 KW (6:1, 9:1 or 1:1 — select one)	15.00
Universal Transmatch 2 KW (6:1, 9:1 or 1:1 — select one)	17.50

Please send large SASE for info.



### AR-200 XL MEDIUM DUTY ANTENNA ROTOR

Select a Heading - Antenna  
Turns and Stops Automatically

\$6995

## SIDEBAND SQUELCH

- Fits inside most HF-SSB transceivers
- Requires human voice to activate
- Ignores static, noise and heterodynes
- On/off switch only—no adjustments!
- Connects to audio leads and 9-12 VDC
- Fully assembled and tested \$99.95
- Complete with comprehensive manual
- Used worldwide in commercial and military transceivers



CMC COMMUNICATIONS  
5479 Jetport, Tampa, FL 33614 (813) 885-3996

170

102 NW BUSINESS PARK LANE  
KANSAS CITY, MISSOURI 64150  
816-741-8118

CALL TOLL FREE  
1-800-821-7323

MASTERCARD VISA & C O D'S WELCOME

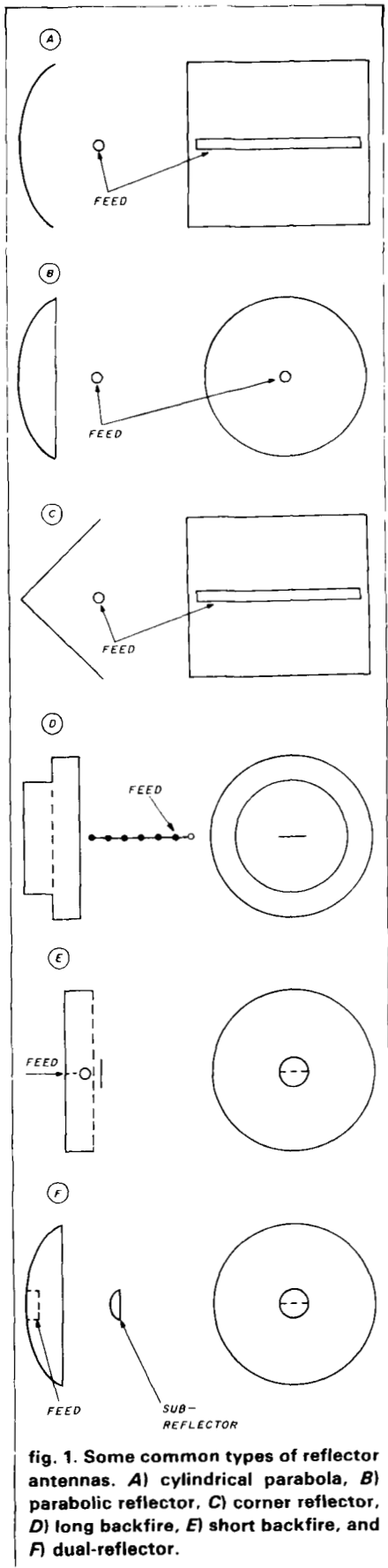

The largest and certainly most famous spherical reflector antenna is at Arecibo, Puerto Rico. Built in the crater of an extinct volcano, it measures 1000 feet (305 meters) in diameter, has a stationary reflector, and uses a special "scalar" feed that can be steered. At 430 MHz, this feed is over 96 feet (28 meters) long!<sup>2</sup>

Other antenna systems use a secondary reflector that allows the feed system to be placed at a more convenient point in the structure (see **fig. 1F**). Examples are the *Gregorian*, *Cassegrain*, and *Newtonian* feed-reflector antennas. There are many other variations of the antennas just described.<sup>2,7,8,9</sup> These variations are associated with the different feed system employed.

The implementation of a secondary type of reflector is usually beyond the reach of the typical Amateur and beyond the scope of this column. The improvement obtained with such systems is often at the expense of considerable complexity, which can often

be offset by designing a slightly larger antenna right from the start — certainly a typical Amateur approach!

### tradeoffs

All types of reflector antenna systems have their advantages and disadvantages. The technical literature on reflector antennas could easily fill a good-sized room! (See references 2, 7, 8, and 9 for starters.) But for the Amateur, the parabolic reflector antenna that uses a prime focus feed system as shown in **fig. 1B** is one of the simplest antennas for obtaining high performance with relatively straightforward construction.

Some of the main advantages of the parabolic dish include its use of a single feed; its ability to operate on other frequency bands by simply exchanging the feed system; its low noise pickup — i.e., its clean radiation pattern. It has reasonable gain for the size of the aperture employed. Its disadvantages include large surface area, which leaves it vulnerable to damage

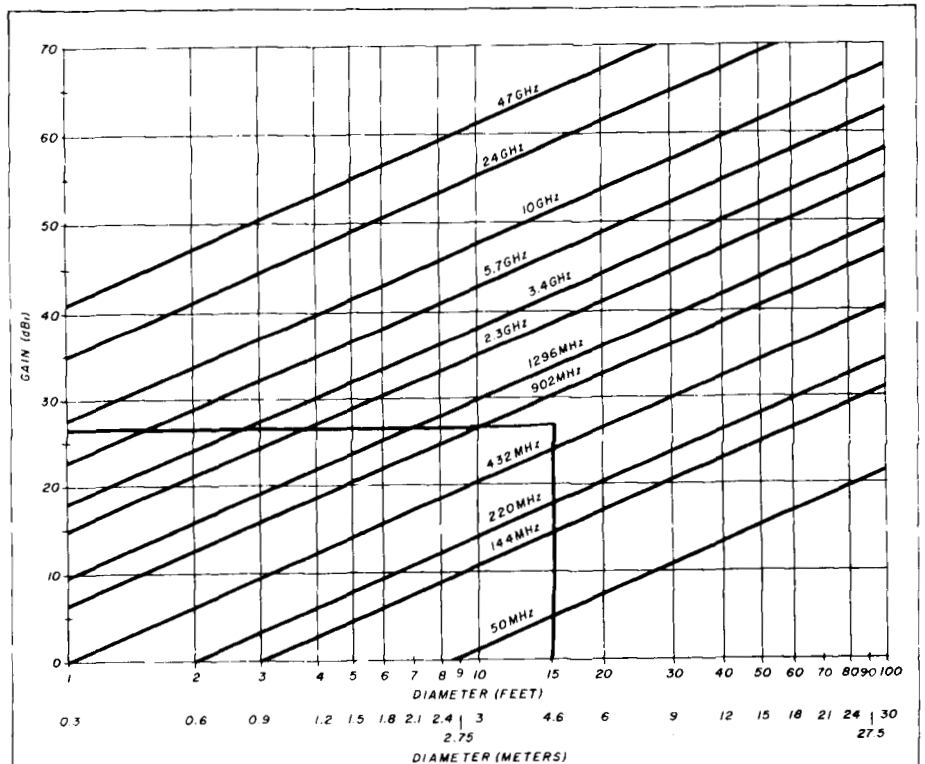

**fig. 2. This graph is a plot of gain versus size for typical parabolic dishes with 55 percent efficiency.**

from wind or snow; comparatively large physical size (for gain) than a Yagi array offering equivalent gain; and the mechanics involved in designing the reflector and rotation system, especially if it's used on EME. Despite these shortcomings, the parabolic dish, with its single feed system, is a natural for the UHF and especially the Amateur microwave bands.

### gain and beamwidth

Generally speaking, the efficiency of a well-designed parabolic dish is in the range of 50 to 60 percent (more on this later). Hence it will have an effective aperture or capture area that is somewhat smaller than its physical area.<sup>10</sup>

Based on a 55-percent efficiency, a typical design standard, the gain of a well-constructed parabolic dish can be easily calculated using Eqn 1.

$$G = 10 \log [0.55 \cdot 4\pi A/2] \quad (1)$$

$$= 10 \log (6.9A/2)$$

where  $G$  is gain in dBi and  $A$  is the area of the reflector. Both area and wavelength must be in the same unit of measure.

For example, the area of a 20-foot (6.1-meter) diameter dish is about 314 square feet (29.2 square meters). At 432 MHz a wavelength is 2.277 feet (0.694 meters). Therefore, using Eqn 1, the gain would be about 26.2 dBi.

You may prefer to work directly in feet/meters and frequency. If so, the following formulas can be derived from Eqn 1.

$$G = -52.4 + 20 \log D + 20 \log F \quad (2)$$

where gain is in dBi,  $D$  is dish diameter in feet and  $F$  is frequency in MHz or

$$G = -42.1 + 20 \log D + 20 \log F \quad (3)$$

where  $G$  is in dBi,  $D$  is dish diameter in meters and  $F$  is in MHz. Eqns 2 and 3 yield the same gains as Eqn 1 without having to first calculate the reflector area.

In order to make it easier to rapidly determine gain, I have prepared the graph in fig. 2, which includes practical size reflectors and gains of 10 to 70

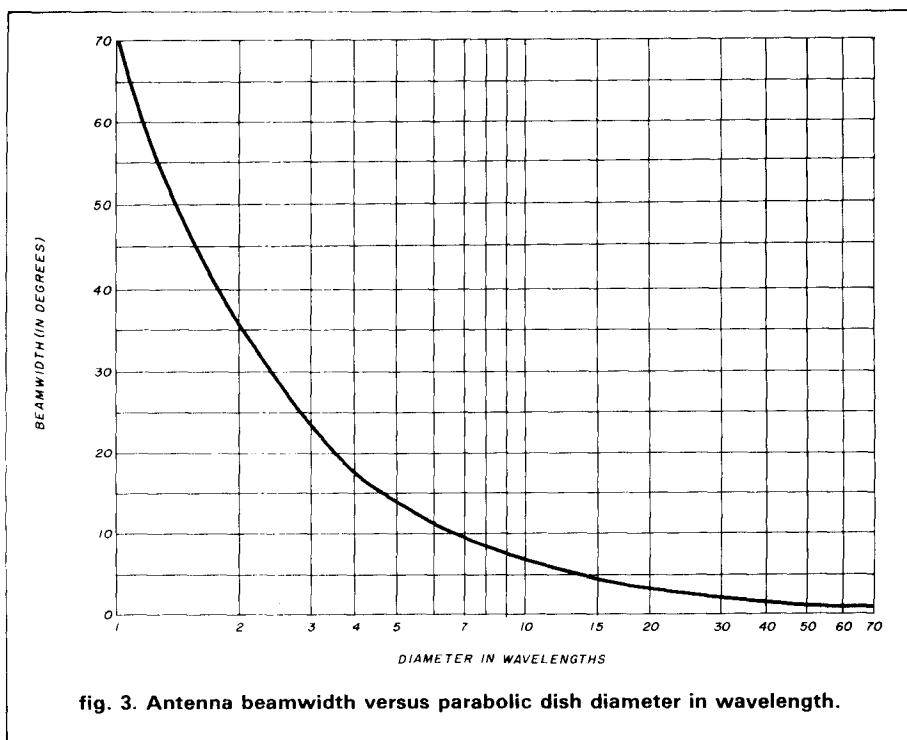

fig. 3. Antenna beamwidth versus parabolic dish diameter in wavelength.

table 1. Typical parabolic curve dimensions for a 20-foot (6.1 meter) diameter parabolic dish with a 0.5 f/d ratio.

distance from center of dish (Y)		depth of dish (X)	
feet	meters	inches	centimeters
1	0.305	0.3	0.76
2	0.61	1.2	3.05
3	0.915	2.7	6.86
4	1.22	4.8	12.19
5	1.52	7.5	19.05
6	1.83	10.8	27.43
7	2.13	14.7	37.34
8	2.44	19.2	48.77
9	2.74	24.3	61.72
10	3.05	30.0	76.2

dBi on most of the popular Amateur VHF/UHF bands. Note that in the example just described, the graph shows the gain to be about 26 dBi, very close to the calculated value!

Finally, it has been pointed out before in this column that as the gain of an antenna increases, the beamwidth decreases.<sup>11</sup> For a parabolic antenna, the beamwidth can easily be determined to a reasonable accuracy ( $\pm 10$  percent) using the following formula:

$$BW \approx 70\lambda/D \quad (4)$$

where  $BW$  is in degrees and  $D$  is the reflector diameter. Both wavelength and diameter must be in the same unit of measure.

For example, the antenna just described has a diameter of approximately 20 feet (6.1 meters). One wavelength at 432 MHz is approximately 2.28 feet (0.694 meters) and 0.76 feet (0.231 meters) at 1296 MHz. Hence its beamwidth would be approximately 8



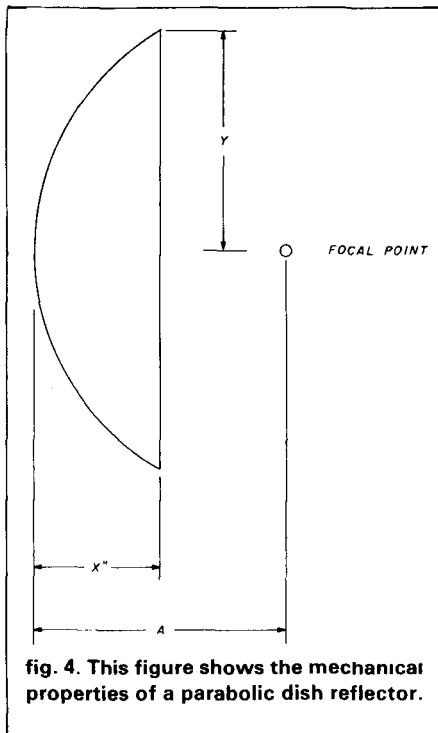

fig. 4. This figure shows the mechanical properties of a parabolic dish reflector.

degrees at 432 MHz and 2.66 degrees at 1296 MHz.

Properly designed, the parabolic dish has a symmetrical beamwidth the same in both E and H planes. The graph in fig. 3 has been prepared to simplify beamwidth estimation.

### design parameters

So how does one go about designing a parabolic dish? What tradeoffs are required? Where do you feed the dish?

First you have to understand the geometry of a parabolic dish. You must have a reflector that follows a parabolic curve. This is described mathematically by Eqn 5 below:

$$Y^2 = 4AX \quad (5)$$

where, referring to fig. 4,  $Y$  is the radius of the reflector,  $A$  is the focal length and  $X$  is the depth of the reflector, all in the same unit of measure.

If the diameter and focal point (as described below) are known, we can rearrange Eqn 5 to a more convenient form as shown below:

$$X = Y^2/4A \quad (6)$$

For instance, suppose that you want

to design a 20-foot (6.1 meter) diameter parabolic dish with a focal length of 10 feet (3.05 meters). Using Eqn 6, the edge of the dish will be 2.5 feet (65 cm) higher than the center of the dish. Likewise, a point halfway from the center will be 0.625 feet (19 cm) above the center, and so forth. Table 1 shows a typical parabolic curve for this example. With all the personal computers available, there are many kinds of programs to simplify the computation of a parabolic curve. References 12 and 13 will help you select such a program.

Finally, if the diameter and depth of the reflector are known, the focal point can be found by rearranging Eqn 5 as follows:

$$A = Y^2/4X \quad (7)$$

If you already have a dish, the focal point can easily be determined using Eqn 7. First measure the reflector diameter with a tape measure. The radius, or  $Y$ , is one-half the diameter. If a board or string is placed on the rim from one side of the reflector to the other, the depth,  $X$ , can be easily measured. For example, if we have a dish with a depth of 2.5 feet (0.762 meters) and a radius of 10 feet (3.048 meters), the focal point will be 10 feet (3.048 meters).

Next we must determine the  $f/d$  or focal length to diameter ratio using the following equation:

$$f/d = A/2Y \quad (8)$$

Using Eqn 8, the  $f/d$  ratio in the example above is 0.5 (10/20 feet or 3.05/6.1 meters). We now have all the mathematical parameters necessary to talk intelligently about the design of a parabolic dish type of antenna.

### parabolic dish characteristics

So why are the diameter, depth, focal point, and  $f/d$  ratio so important? It should be intuitive that the diameter of the reflector is the principal factor that determines the gain of a parabolic antenna. The larger the diameter, the higher the potential gain, as shown on the graph on fig. 2.

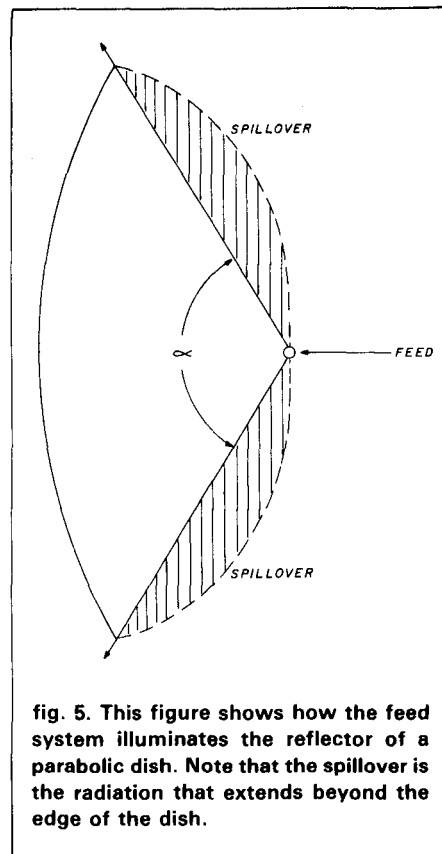

fig. 5. This figure shows how the feed system illuminates the reflector of a parabolic dish. Note that the spillover is the radiation that extends beyond the edge of the dish.

The reflector must follow a parabolic profile (see eqn. 5). This curve is calculated after the diameter and  $f/d$  ratio of the dish are selected. As dish diameter increases, greater care must be taken to maintain the shape of the reflector.

The depth of the reflector is the parameter that determines the focal length: the deeper the dish, the shorter its focal length. In a "deep" dish, where the  $f/d$  ratio is approximately 0.25, the focal point will be on a line parallel to the rim of the dish. The "flatter" the dish, the longer the focal length — and the more difficult it becomes to hold the feed system in place mechanically.

The  $f/d$  ratio, however, is probably the most important parameter when designing a parabolic dish antenna from scratch. Let's see why.

In order to use the parabolic dish reflector properly, the feed system must be placed at or near the focal point. Because this feed system "looks" into the dish from the focal point, it must illuminate the subtended



JÄ

# THE MOST Ku READY SATELLITE TV SYSTEM IN THE WHOLE VIDE WORLD.

Luxor has been Ku ready long before the rest of the world ever heard of satellite television.

Then came the eighties when we introduced America to its first Ku and C-band block receiver: Luxor's 9570 Mark II.

Today there's a full line of Luxor Systems. Like our 9995, designed as an inexpensive stand alone or for multiple television installations.

And now the Luxor 9900—the world's easiest to use Satellite Television System.

Call Luxor at  
1-800-245-9995.

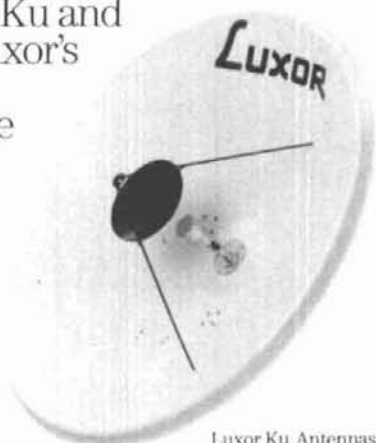

Luxor Ku Antennas.



9995 Block Receiver.



Microwave  
Block Downconverter



9570 Mark II Block Receiver.



9900 Block Receiver.

## LUXOR®

*Luxor of Scandinavia.  
The birthplace of Satellite Television.*

angle between the rims of the dish with a properly tapered radiation pattern as shown in **fig. 5**. (More on this shortly.)

If you have a deep dish with an  $f/d$  ratio between 0.25 and 0.4, this subtended angle will be quite large — from 180 to 128 degrees, respectively. If a dish is relatively flat with an  $f/d$  ratio between 0.5 and 0.8, the subtended angle will be only 106 to 70 degrees, respectively. For convenience, various subtended angles versus  $f/d$  ratios have been plotted in **fig. 6**.

Why is this angle so important? The reasons are many, and all are related to the  $f/d$  ratio. Let's first look at some of the tradeoffs.

There are advantages to a low  $f/d$  ratio (0.25 to 0.4). This type of dish has a short focal length and hence the support of the feed system is easier from a mechanical standpoint. Generally speaking, the deep dish is quieter on reception. A 0.35 to 0.4  $f/d$  ratio is very common in commercial dishes.

There are also disadvantages to a low  $f/d$  ratio. The feed system has to see a wide angle as previously discussed; this makes the feed system more difficult to design. The proximity of the feed to the reflector can cause the feed impedance to change when it's mounted at the focal point. From a mechanical point of view, the deeper the curve, the more difficult is to fabricate the reflector. There's also greater likelihood that the polarity will become distorted. Usually the low  $f/d$  ratio dish demonstrates only moderate efficiency.

A high  $f/d$  ratio (0.5 to 0.6) offers several advantages. Because its illumination angle is narrower, the feed system is usually easier to design. The reflector has a flatter profile, making it easier to fabricate. Since the feed point is further from the reflector, it's less likely to be detuned by the reflector. Overall reflector efficiency is generally higher than in a dish with a low  $f/d$  ratio.

There are some disadvantages to a high  $f/d$  ratio. The feed system, for example, is much further from the reflector and hence more difficult to

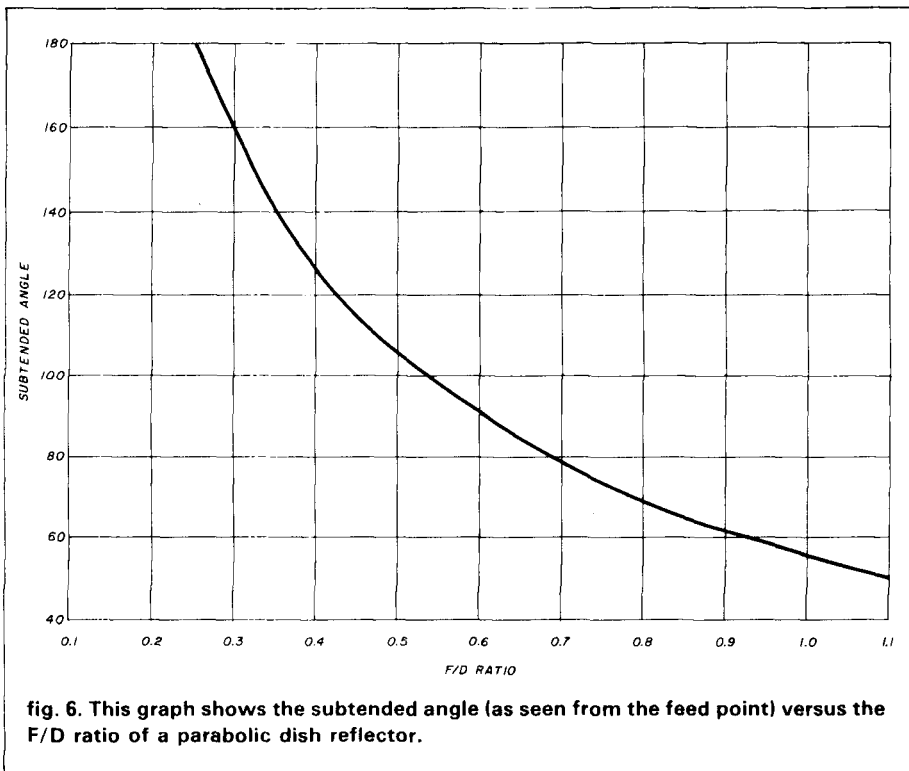

**fig. 6.** This graph shows the subtended angle (as seen from the feed point) versus the  $F/D$  ratio of a parabolic dish reflector.

**table 2.** Gain and sidelobe levels versus illumination taper on a typical well-designed parabolic dish.

edge illumination in dB	typical level of first sidelobe	approximate overall aperture efficiency (%)
-6	-20.0	68.0
-10	-23.5	81.0
-15	-31.0	77.5
-20	-46.0	69.0

support. Even if the feed system is properly designed, there will be more spillover and hence more noise pickup than would be expected in a low  $f/d$  ratio dish.

When designing a dish, therefore, the main considerations are the mechanical design and the feed system, which are both governed by the  $f/d$  ratio as discussed. From our point of view, as Amateurs, an  $f/d$  ratio of 0.45-0.6 seems to be the best compromise since the feed system and the surface of the reflector are easier to design.

## feed systems

So far the feed system itself has

been mentioned only in passing. Let's look more deeply into the way it has to perform.

As I said earlier, the feed system must illuminate the subtended angle. Furthermore, a parabolic dish is symmetrical in the horizontal as well as the vertical plane, so the feed system must also be symmetrical in both planes.

Although actual feed systems will be discussed in next month's column, their requirements will be spelled out now. It would appear that the feed system should have a half-power beamwidth equal to the illumination angle as shown in **fig. 6**. However, if this were true, a considerable amount of the feed power would be lost

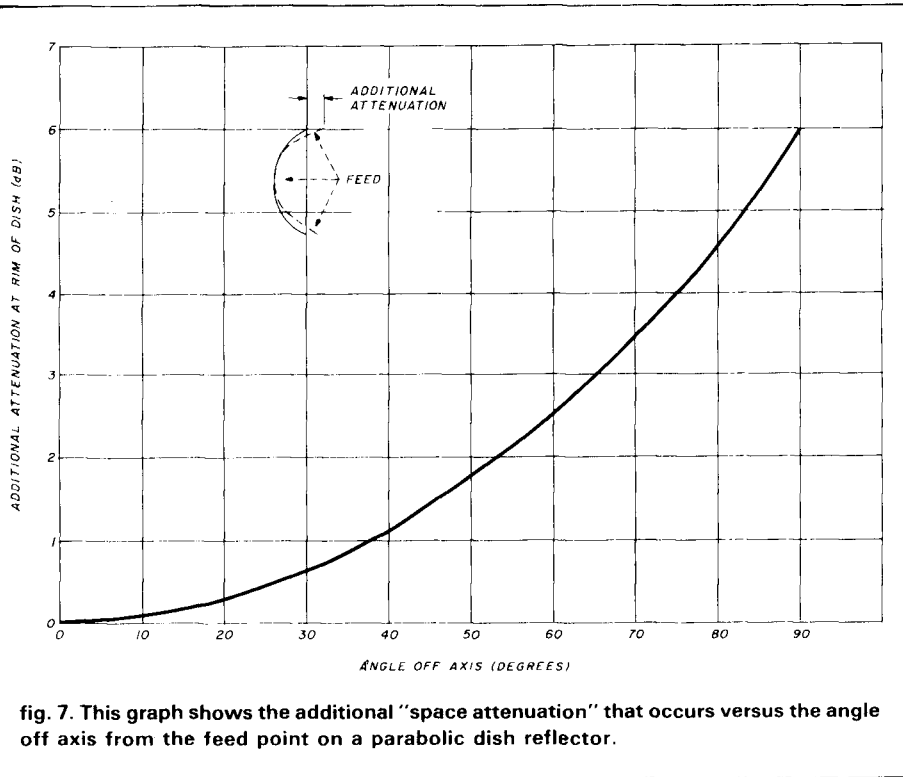

because of "spillover" (see **fig. 5**). Therefore the sidelobes would be high, and in the case of EME, considerable noise would be picked up off the rear of the dish, which is usually the warm earth at 290 degrees Kelvin. On the other hand, if the illuminator feed angle were too narrow, only the center of the reflector would be active and the efficiency of the antenna would decrease — but so would the sidelobes, etc.

Silver<sup>7</sup> and others has discussed this relationship in detail. Most engineers agree that for best overall performance, the optimum feed system should have its -10 dB points right on the rim of the dish. This will yield a reasonably clean pattern and fair gain. The first side lobes will be approximately 23 dB below the main beam. Some typical illumination tapers are shown in **table 2**.

Over-illumination with less than 10 dB feed system taper at the rim of the dish will cause spillover, lower gain, and sidelobes that will be less than 23 dB below the main beam. Conversely, if the dish is under-illuminated and the taper at the rim of the dish is too great,

the gain will decrease, as will the side lobes and the noise pickup.

Another factor must be considered: the distance from the reflector to the feed point changes across the reflector. So you can't assume that the feed must be optimum just because the feed system has a -10 dB beamwidth equal to the subtended angle. **Figure 7** shows this amplitude taper as a function of the angle as seen from the feed system. Hence this additional factor has to be taken into consideration when choosing the feed system and the f/d ratio. The lower the f/d ratio is, the greater the "space loss" taper at the edge of the dish will be.

### summary

This concludes part 1 of our discussion on the subject of reflector antennas. This month's column has described the relationship between electrical and mechanical considerations in designing a reflector-type antenna and, more specifically, a parabolic dish antenna.

It has also been shown that design tradeoffs are primarily linked to the f/d ratio chosen. Next month's column

will deal more with the mechanical design of a reflector and the electrical design of its feed system. Once you have this material in hand, you should be able to design your own parabolic dish antenna and know that it will work as planned!

### references

1. Joe Reisert, W1JR, "VHF/UHF World: Our Amateur Microwave Bands", *ham radio*, January, 1986, page 44.
2. A. W. Love, *Reflector Antennas*, IEEE Press, 1978.
3. Francis LeBaron, W1TOZ, "A Home-Built Parabolic-Type Reflector for 1296 Mc.," *QST*, April, 1961, page 11.
4. J. D. Kraus, "The Corner Reflector Antenna," *Proceedings of the IRE*, Volume 28, November, 1940, page 513.
5. H. W. Ehrenspeck, "The Backfire Antenna, A New Type of Directional Line Source," *Proceedings of the IEEE*, January, 1960, page 109.
6. H. W. Ehrenspeck, "The Short-Backfire Antenna," *Proceedings of the IEEE*, August, 1965, page 1138.
7. Samuel Silver, *Microwave Antenna Theory and Design*, Massachusetts Institute of Technology Radio Lab No. 12, Boston Technical Publishers, 1964.
8. John D. Kraus, *Antennas*, McGraw-Hill Book Company, 1950.
9. Henry Jasik and Richard C. Johnson, *Antenna Engineering Handbook*, Second Edition, McGraw-Hill Book Company, 1984.
10. Joe Reisert, W1JR, "VHF/UHF World: Stacking Antennas — Part 1," *ham radio*, April, 1985, page 129.
11. Joe Reisert, W1JR, "VHF/UHF World: Determining VHF/UHF Antenna Performance," *ham radio*, May, 1984, page 110.
12. *RF CAD Package — Version 3.50*, Computer-aided design package for radio frequency and microwave circuits and antennas (IBM PC and compatibles), by Joe Reisert, W1JR, and Gary Field, WA1GRC. Available from Ham Radio's Bookstore, Greenville, New Hampshire 03048 \$39.95 plus \$3.50 shipping and handling.)
13. Don Cook, K1DPP (see callbook) has a free program listing for Commodore 64 computers. Enclose SASE with request.

### important VHF/UHF events

- February 4: *EME perigee*
- March 1: *EME perigee*
- March 21: *TE propagation optimum ± 2 weeks*
- March 28: *EME perigee*

ham radio



# The ISOTRON

NO TUNERS!  
NO RADIALS!

ANTENNAS FROM 160-10 METERS NO COMPROMISE!

## Just a few comments from our satisfied customers:

"... I have used your 80/40 meter Isotron while stationed in Guantanamo Bay Cuba and it worked great!... Dept. Of The Navy"

"On January 11 and 12 I got into the 7th magazine ssb contest. I didn't try for maximum number of contacts. Rather I tried for maximum number of states. In less than 8 hours total time I worked 52 states and Puerto Rico, that last one is about a 2800 mile haul from Aurora, Colorado.

Not too bad for what looks like a bird feeder... W2RQ"

"I just got my Isotron 40 on the air and it has surpassed my wildest expectations. My first evening QSO was with KB6EUC and wait—my second was with HK2GUP in Columbia, South America. The antenna sits on a 20 foot mast and that is it. My RST reports have been great.

Congratulations on developing the Isotron. I am spreading the good word among my ham friends. I think it's a super, compact antenna whose time has finally come!... KA2QWE"

"About two months ago I bought an Isotron 80 and just recently got it out of the shack and up on a 18-foot pole. I am really intrigued by it and have had a lot of fun trying to convince other stations that it is only 28 inches high. I worked California when it was hanging by a nylon cord from the ceiling of the shack and it works even better out on a pole... N2EDF"

WHY NOT ENJOY THEIR OPERATING PLEASURE & GIVE US A CALL. WE WILL LOOK FORWARD TO TALKING WITH YOU.

\*40-METER - \$52.95 PLUS \$3.75 SHIPPING 80-METER - \$63.95 Plus \$4.75 Shipping  
80-40 Combination - \$110.00 plus \$8.50 Shipping

pictured—  
Isotron 160

ASK FOR PRICES ON OTHER MODELS

\* See review in October 73, 1984.

**BILAL COMPANY**

S.R. 2, Box 62, Dept. 91

Eucha, OK. 74342 PH: 918-253-4094

✓ 173

**AVAILABLE  
NOW**

## THE 1986 ARRL HANDBOOK FOR THE RADIO AMATEUR

Great gift idea for a ham friend or for yourself!

The new 1986 ARRL HANDBOOK is chockfull of projects, ideas, hints and kinks, theory and thousands of other handy things for your hamshack. New items include: switching power supplies, data and telemetry transmission, a section on conjugate matching by Walt Maxwell, data interface and Packet Radio, and remote control aircraft to name just a few examples. New projects include: 30 amp power supply, ATV monitoring instruments, digital frequency synthesizer, 1500 watt output 160 meter amplifier, state-of-the-art preamps for all Amateur VHF/UHF frequencies and much, much more. A grand total of 244 new pages! This is the reference book to have. Order your's today. - 1985 Over 1100 pages.

AR-HB86  
AR-BB86

Softbound \$17.95  
Hardbound \$26.95



Please enclose \$3.50 to cover shipping and handling



**ham  
radio** magazine **BOOKSTORE**  
GREENVILLE, NH 03048



The monthly magazine with a natural blending of two popular hobbies — Ham Radio and Computers

- ★ Articles on Ham Radio & Most Personal Computers
- ★ Hardware & Software Reviews
- ★ Various Computer Languages
- ★ Construction Articles
- ★ Much Much More...

"...received my moneys worth with just one issue..."

—J. Trenbick

"...always stop to read CTM, even though most other magazines I receive (and write for) only get cursory examination..."

—Fred Blechman, K6UGT

U.S.A. .... \$15.00 for 1 year  
Mexico, Canada ..... \$25.00  
Foreign ..... \$35.00(land) - \$55.00(air)  
(U.S. funds only)  
Permanent (U.S. Subscription) ..... \$100.00  
Sample Copy ..... \$3.50



Circulation Manager

1704 Sam Drive

Birmingham, Alabama 35235

Phone 205/854-0271

Name \_\_\_\_\_

Call Sign \_\_\_\_\_

Address \_\_\_\_\_

City \_\_\_\_\_ State \_\_\_\_\_

Zip \_\_\_\_\_ Phone \_\_\_\_\_

Date \_\_\_\_\_

Signature \_\_\_\_\_

✓ 162

# improving the audio on the ICOM IC-27

Make an otherwise  
fine radio even better

The ICOM IC-27 FM transceiver remains, in my opinion, one of the most compact and versatile mobile units available. The performance of my IC-27A was very impressive, with just one noticeable exception: the received audio was poor. Low volume and poor treble response made many noise-free signals all but unintelligible. Many other Amateurs have experienced this problem as well. Fortunately, there's a very simple remedy.

My first inclination was to experiment with an external speaker. The speaker included in the IC-27 is very small. Often such small speakers are inefficient and have poor response. Yet experimentation with a much larger speaker with a more powerful magnet showed absolutely no discernible difference. The only way one could hope to increase the volume would be by mounting an external speaker closer to the user's ear. This would alleviate only part of the problem, however, since the tonal response would remain virtually unchanged. The latter fact was an important clue, because it led me to believe that the audio amplifier inside the IC-27 was the culprit.

## strategy

The solution to this problem is simple. Just change one resistor and one capacitor in the audio section. There's absolutely no reason to fear the operation; it's very simple. ICOM has provided excellent schematics with the radio, the board layout is not terribly compact in this area, and all cables running to the important circuit board are provided with well labeled pull-off connectors in an unambiguous configuration. Aside from forgetting to replace a connector, it's virtually impossible to connect anything incorrectly.

As shown in the ICOM schematic, not reproduced here, Q5 and Q6 form an active filter which seems to

effectively filter the intelligibility of many Amateurs' speech. Capacitor C67 was found to form the bottleneck; a smaller value is required here. This greatly improves the treble response.

The audio output power was increased by changing the feedback resistor, R31, of the audio power amp, IC6 (on the ICOM schematic). It was discovered that a larger value would give greater gain while still not introducing objectionable distortion.

## modification procedure

Begin the modification by turning the transceiver over (speaker side up), and removing the four screws holding the bottom cover. Carefully place the bottom cover to the side (as shown in fig. 1) so as not to strain the speaker wires. The connector for the speaker wires can then be pulled at the circuit board.

The objective is to remove the circuit board in order to gain access to the parts which must be changed. Carefully remove connectors J2, J6, J10, and J12. With your fingers, remove the cover plate of the synthesizer section (it's the large shiny box on the right-hand side). Remove the four screws in the corners of the large circuit board. Remove J1 (the entire circuit board at the rear of the unit). Remove the two heat sink screws on IC5 and IC6. Remove the hex spacer formerly under the rear circuit board.

At this point, the entire circuit board can be lifted out. Carefully pull it out and locate the audio section toward the front on the left side, as viewed from the component side. Locate C67. This is a 0.01  $\mu$ F capacitor near IC6. Using a solder wick or a solder sucker, remove C67 and replace it with a tiny 0.001  $\mu$ F capacitor. A small ceramic part will do nicely. Then locate R31. This is a 150-ohm, 1/8 watt resistor near J6. Replace this with a 270-ohm resistor. If possible, use a 1/8 watt part so that it will fit easily in the circuit board. Clean your solder connections and carefully check for solder bridges.

This completes the modifications. Replace the circuit board and reverse the disassembly procedure, being careful to replace all removed connectors.

By Edward Richley, KD8KZ, 41 High Point Circle, Naples, Florida 33940

# Your Ham Tube Headquarters!

TUBES BOUGHT, SOLD AND TRADED  
SAVE \$\$\$—HIGH \$\$\$ FOR YOUR TUBES

Call Toll Free 800-221-0860

## Tubes

3-400Z.....	\$85.00	7360.....	\$13.75
3-500Z.....	85.00	6550A.....	7.50
4-400A.....	80.00	8072.....	125.00
4CX250B.....	59.00	8156.....	12.50
572B.....	57.00	8643.....	82.50
811A.....	12.00	8844.....	26.50
813.....	30.00	8873.....	195.00
6146B.....	8.50	8874.....	225.00
6360.....	4.25	8877.....	595.00
6883B.....	8.00	8908.....	14.50

## MAJOR BRANDS ON RECEIVER TUBES 75% off list

### Semiconductors

MRF 245/SD1416 ..	\$30.00	SD1088 .....	19.95
MRF 454 .....	14.95	2N3055.....	.75¢
MRF 455 .....	10.95	2N6084.....	12.50

### RF Connectors

PL259.....	10/\$4.95	M358.....	2.50 ea.
PL258.....	10/8.95	M359.....	1.75 ea.
UG 175/176.....	10/1.60	Type "N" Twist on	
UG255/u.....	2.50 ea.	(RG8/u).....	\$4.75 ea.
UG273/u.....	2.25 ea.	Minimum Order	\$25.00

Allow \$3.00 min. for UPS charges ✓ 171

# CeCo

COMMUNICATIONS, Inc.

2115 Avenue X Brooklyn, NY 11235

Phone (212) 646-6300

SERVING THE INDUSTRY SINCE 1922

Call CECO For Your CCTV Security And Color Production Requirements

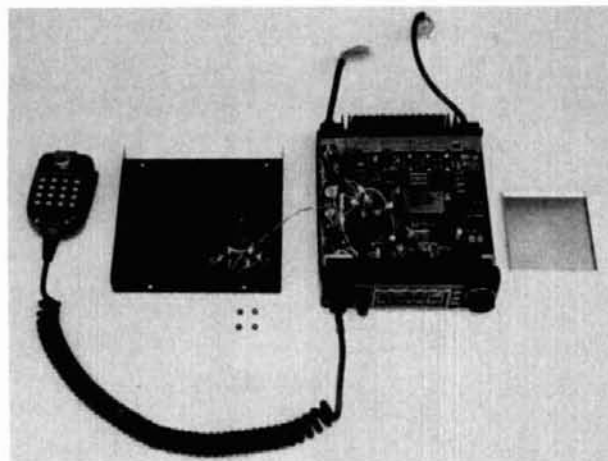

fig. 1. The ICOM IC-27 is easily disassembled for modification.

## results

After performing these modifications, I was much happier with the IC-27. Audio volume and clarity are much better than with the original unit, even with the original speaker. In fact, I seriously doubt the need for an external speaker. The internal speaker provides plenty of power, even in my very noisy automobile. I'm sure other Amateurs will agree that this modification makes an otherwise superb radio even better.

ham radio



P.O. Box 4405  
220 N. Fulton Ave.  
Evansville, IN 47710

Stores Hours  
MON-FRI 9AM-6PM  
SAT 9AM-3PM

WARRANTY SERVICE CENTER FOR:  
ICOM, YAESU, TEN-TEC

### TERMS:

Prices Do Not Include Shipping.  
Price and Availability Subject to  
Change Without Notice  
UPS COD \$2.50 Per Package

### USED EQUIPMENT

<b>ASTRON</b>	
VS-35M 25-35A Variable w/meter.	\$ 139.95
<b>AZDEN</b>	
PCS-3000	\$ 175.00
PCS-2000	169.95
PCS-300 2M H.T.	174.95
Remote Cable-3000	25.00
<b>COLLINS</b>	
75S-3/CW NARROW	\$ 249.95
32S-3 XMTR/516F-2 P.S.	399.95

<b>DENTRON</b>	
Super Super Tuner (C)	129.95
Clipperton L Amp. (C)	449.95
<b>DRAKE</b>	
L4B Amp (C)	\$ 699.95
TR4C, AC4, MS4	299.95
MN2000 Tuner	149.00
UV-3 (2M & 440) W/TT MIC, P.S.4	429.00
R4A Rcvr (C)	129.95
<b>ENCOMM</b>	
ST-144 2M H.T.	\$ 185.00
HT-1200 2M H.T.	139.50
ST-440 440 MHZ H.T.	179.95
ST-77 440 MHZ H.T.	109.95
HL-32V 2/30 AMP	59.95
<b>HAL</b>	
MPT-3100 (No Monitor)	\$1495.00
CT2200/KB2100	525.00
<b>HEATHKIT</b>	
SB-200 AMP	329.95
SA-2040 2 KW/Tuner	139.50
HR-1680 Rcvr	79.95
VL-1180 10/80 W 2M AMP	89.95
HP-23B Power Supply	69.95
1M-4190 VHF-UHF Mtr	89.95
HW-7 XCVR	69.95
SA-2060 2KW Tuner w/MTRS	189.95
<b>ICOM</b>	
745/P S	\$ 715.00
740/P S	639.95
740	539.95
730	459.95
R-70 Gen Cov Rcvr.	439.95
25H 45W 2 MTR (C)	249.00
255A 2 MTR	185.00
260A 2 MTR All Mode	269.95
3AT 220 MHZ H.T.	189.95
PS-15 P.S.	99.95
2AT 2 MTR H.T.	159.95
<b>KANTRONICS</b>	
Interface II	\$ 179.95
Mini-Terminal	109.95
Varifilter	49.95
Amtror Soft (VIC 20)	29.95
<b>KENWOOD</b>	
TS820S	\$ 459.95
TS120S	369.95
TS520SE	429.95
TS520	389.95
TR2600 2M H.T.	229.95
TR2400 2M H.T.	169.95

<b>KENWOOD</b>	
TR8400 440 MHZ	185.00
7930 2M Mobile	269.95
RM-76 Microprocessor	45.00
BS-5 Pan Kit	49.00
DC-Module (520 or 820)	55.00
R-11 Gen. Cov. Rcvr.	55.00
PC-1 Phone Patch	49.00
<b>MFJ</b>	
941B Tuner	\$ 59.95
732 Filter	45.00
410 Prof. Morse Keyer/Trainer (C)	89.95
<b>SWAN</b>	
Cubic Astro 150	\$ 329.95
100 MX XCVR (C)	249.95
700 CX, P.S. (C)	399.95
350C, PS (C)	239.95
350B (C)	119.95
MARK I Amp 700W out CW (C)	259.95
MARK II Amp 950W out CW (C)	475.00
MARK II Amp 1KW out CW (C)	515.00
600-T XMTR (C)	559.00
89.95	
<b>TEN-TEC</b>	
Titan Amp	\$1850.00
OMNI-C	599.95
OMNI-A/B	299.95
280 P.S.	109.95
Century 22	289.00
Century 21	199.95
Triton IV Digital	329.95
262G P.S./Spkr	89.95
214 Electret Mic	35.00
2591 2M H.T.	189.95
<b>YAESU</b>	
FT980/Gen.Cov.XMT.	\$1175.00
SP980 Spkr/Audio Filt.	45.00
FT980, Am filter, Gen.Cov.XMT.	1195.00
FT980, Keyer	1175.00
FT107M/DMS/FP107E P.S.	569.00
FT901DM Fan, CW, SSB Filters	599.95
FT901DM Fan, CW	579.95
FV901DM Remote VFO	169.00
FT101ZD, CW, Fan	549.95
FT101ZD, AM, Fan	549.95
FT101ZD, AM, Warc Bands	549.95
FT101Z, CW, Fan	459.95
FV101Z Remote VFO	105.00
FT101E, CW	449.95
FT101E, Fan	429.95
FT101B, Fan	369.95

<b>YAESU</b>	
FL101, XMTR	189.95
YC-601 Dig. Readout	175.00
FT-7 20W XCVR	279.95
FL-110 Amp	149.95
FT726R Multi Mode	669.95
FT221 2M All Mode	249.95
FT221/w/Preamp	269.95
FP-757 H.D.	140.00
FRG 7700/MEM	319.95
<b>MISC.</b>	
TEMPO 2020	\$ 269.95
TEMPO one w/P.S.	125.00
NDI HC1400 2M 25w/TTMic	125.00
Alliance HD-73 (C)	65.00
Vista XR Power Supply	39.95
<b>DEMONSTRATORS</b>	
<b>AEA</b>	
MBA-20 Text	\$ 45.00
<b>ASTRON</b>	
V550M Power Supply	\$ 219.95
<b>ENCOMM</b>	
ST200 ET 2M, H.T.	\$ 159.95
ST-442 440 MHZ H.T.	249.95
HT-77 440 MHZ H.T.	79.95
<b>ICOM</b>	
751/P S	\$1099.00
471H 430-450 MHZ	850.00
271H 100W 2MTR	675.00
<b>MFJ</b>	
825 P.E.P. MTR	\$ 50.00
2044 2M Amp	50.00
<b>NYE</b>	
MB-V Tuner	\$ 399.00
<b>TOKYO HY-PWR</b>	
10/160V 2M Amp	\$ 255.00
HL90U 440MHZ Amp	299.95
<b>VOCOMM</b>	
25/100W 2M Amp	\$ 109.95
<b>YAESU</b>	
2700RH 2MTR/440MHZ	\$ 465.00
270RH/Voice	350.00
SP980 Spkr/Filters	42.50
NC-8 Base Chgr	79.95
FT757AT Tuner	225.00

For Orders and Price Checks Call 800-523-7731

Indiana call 1-812-422-0231  
Service Dept. 1-812-422-0252

# AMERITRON AL-1200 LINEAR AMPLIFIER

WITH THE NEW EIMAC 3CX1200 CERAMIC TUBE

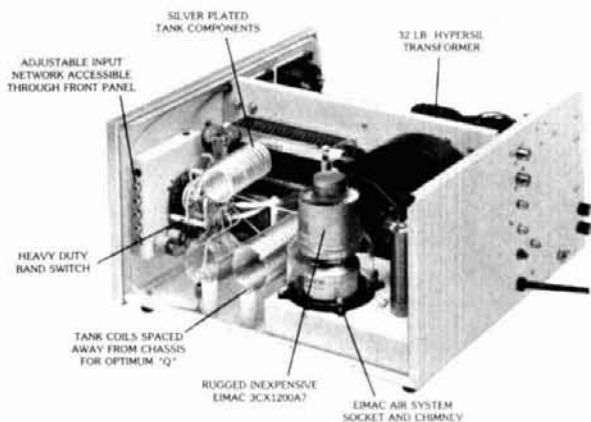

## 1500 WATTS OUTPUT, ALL MODES 160 THROUGH 15 METERS

- Pi-L network with heavy duty components.
- High efficiency bias setting for RTTY/CW.
- ALC compatible with all popular transceivers.
- Peak-reading output meter.
- 32 lb. Peter Dahl hypersil transformer.
- Bridge rectifier supply with computer grade capacitors.
- Inexpensive, instant warm-up tube.
- Full shielding for minimum TVI.



### ATR-10 TUNER

The Ameritron ATR-10 has a unique bandpass network that provides superior harmonic suppression and image rejection. It will safely handle 900 watts of envelope power from 160 through 10 meters. A heavy duty antenna switch permits selection of 5 outputs. It has a peak reading wattmeter, SWR bridge and a dual ratio balun.

duty antenna switch permits selection of 5 outputs. It has a peak reading wattmeter, SWR bridge and a dual ratio balun.

### ATR-15 TUNER

The Ameritron ATR-15 is a 1500 watt "T" network tuner that covers 1.8 through 30 MHz in 10 dedicated bands. Handles full legal power on all amateur bands above 1.8 MHz.

Five outputs are selected from a heavy duty antenna switch. The ATR-15 has a peak reading watt meter, SWR bridge and a dual ratio balun. Size: 6"H. x 13 1/4"W. x 16"D.



### RCS-8 REMOTE COAX SWITCH

The Ameritron RCS-8 is a remote controlled coaxial R.F. switch that allows you to operate up to five separate antennas with only one coax feed line.

The switching box can be tower or mast mounted and the control console is located at your operating station. They are interconnected by a 5 conductor cable (not supplied). 240 volt export model available.



Available at your dealer — Send for a catalog of the complete AMERITRON line.

AMERITRON, Division of Prime Instruments, Inc.

9805 Walford Avenue • Cleveland, Ohio 44102 • (216) 651-1740

**GROTH-Type**  
**COUNTS & DISPLAYS YOUR TURNS**

- 99.99 Turns
- One Hole Panel Mount
- Handy Logging Area
- Spinner Handle Available

Case: 2x4"; shaft 1/4" x 3"

TC2	\$12.50	Model TC2: Skirt 2-1/8"; Knob 1-5/8"
TC3	\$13.50	Model TC3: Skirt 3"; Knob 2-3/8"

Spinner Handle Add \$1.50  
Prices include UPS or Parcel Post in US

**R. H. BAUMAN SALES**  
P.O. Box 122, Itasca, Ill. 60143

174

**Crystal Filters**

For most Ham Rigs from:  
KENWOOD - YAESU - HEATHKIT  
Also DRAKE R-4C/7 Line, COLLINS 75S3-B/C, and ICOM (FL44A Twin Only)

**Finest 8-pole Construction**  
**ALL POPULAR TYPES IN STOCK**  
**CW - SSB - AM**

Phone for information or to Order.  
VISA/MC or COD accepted.

**FOX-TANGO Corp.**  
Box 15944, W. Palm Bch, FL 33416  
Telephone: (305) 683-9587

**ALL BAND TRAP VERTICAL ANTENNAS!**

FULL 1/4th WAVE - All Bands! Automatic Selection with proven Hi-Q Traps. 5 Models - ALL self supporting - Ground or roof mount. HI STRENGTH FIBERGLASS TUBING OVER - ALL NO WOBBLY, LUMPY TRAPS - NO UNSIGHTLY CLAMPS needed - Size 1 1/4" all the way up - Traps hidden inside. You can use it in a 1 ft. sq. Backyard FOR APARTMENTS, MOBILE HOMES - CONDOS etc. where minimum space and neat appearance is MANDATORY! Instant "Drive In" ground mount (included). Use with or without radials (included) (All angle roof mount - Extra) COMPLETELY PRE-TUNED - NO ADJUSTMENTS NEEDED EVER! NO TUNER NEEDED FOR MOST TRANSCEIVERS! Use - RGRU feedline, any length! 2000 Watt PEP input power. Shipped - PREPAID IN USA. Assembles in 10 min. using only screwdriver. WEATHERPROOF!

No. - AVT80-10	5 Band	25'6"	\$199.95
No. - AVT40-10	4 Band	18'9"	\$139.95
No. - AVT20-10	3 Band	11'4"	\$109.95
No. - AVT80-10-3	6 Band	24'8"	\$229.95
No. - AVT40-10-3	5 Band	17'9"	\$159.95

SEND FULL PRICE FOR PP DEL IN USA (Canada is \$10.00 extra for postage, clerical, Customs for order using VISA, MASTER CARD or AMER-EXP Ph 1-308-236-5333) 9AM-5PM weekdays. We ship in 2-3 days. All Antennas Guaranteed for 1 year - 10 day money back trial. Free Inf.

**WESTERN ELECTRONICS**  
Dept. AH Kearney Ne. 68847

178

102

# LEWIS ELECTRONICS COMPANY

THE SOURCE FOR **SATELLITE TV**

## We Are A Name To Remember !

FEB. 22-23  
COME JOIN US FOR THE  
GRAND OPENING CELEBRATION  
LEWIS ELECTRONICS WEST  
6227 EASTSIDE RD.  
ANDERSON, CA 96007  
(916) 365-9136

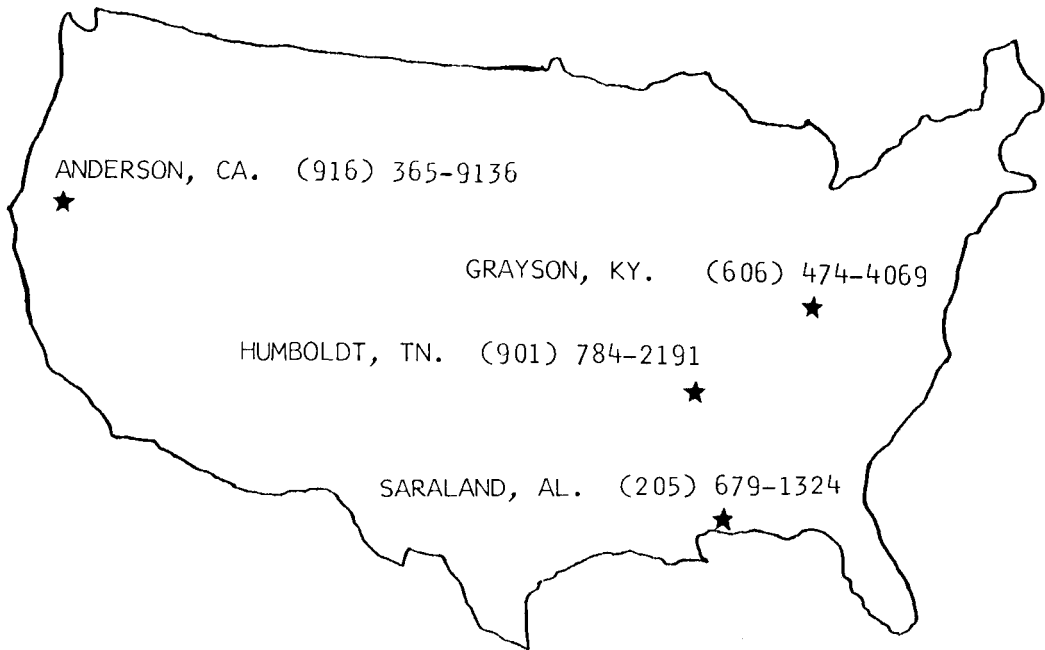

**U.S. ORDER LINE 1-800-972-3474**  
**TENN ORDER LINE 1-800-457-3474**

SEND US A COPY OF YOUR BUSINESS LICENSE FOR OUR NEW DEALER CATALOG AND PRICE LIST.

**LEWIS ELECTRONICS COMPANY**

P. O. Box 100

Humboldt, Tenn. 38343

✓ 140



# ham radio TECHNIQUES

Bill Over  
W6SAI

## what others think of us

When asked about the place of Amateur Radio in today's rapid technological expansion, academician Vladimir Aleksandrovich Kotelnikov, Vice President of the Academy of Sciences of the USSR and Director of the Institute of Radiotechnology and Electronics of the Academy of Sciences of the USSR, said (in part), "One of the needs of man is the need to create. Amateur Radio opens up broad possibilities in this connection for youths as well as for adults. . . ."

"Amateur Radio has been and remains a wonderful school for mass training of personnel for radio electronics. Many young people entered radio electronics via Amateur Radio, judging by our experience. . . ."

"The main goal of Amateur creativity has remained unchanged — to attract youth to active participation in the struggle for technical progress and to teach inventiveness, innovation, and improvements in technology. This is very important for our country." (And for ours, too — Ed.)

## quad falling apart?

One of the problems with the multi-element quad antenna is keeping it in the air during the months of bad weather. The point at which the loop wire and support structure meet is an area of particular weakness in this design. If fiberglass or bamboo poles are used, the copper antenna wire will "saw" back and forth at this point under the movement of the element in the wind. This sawing motion often results in the breaking of either the support pole or the wire, and the whole antenna must be taken down for repairs.

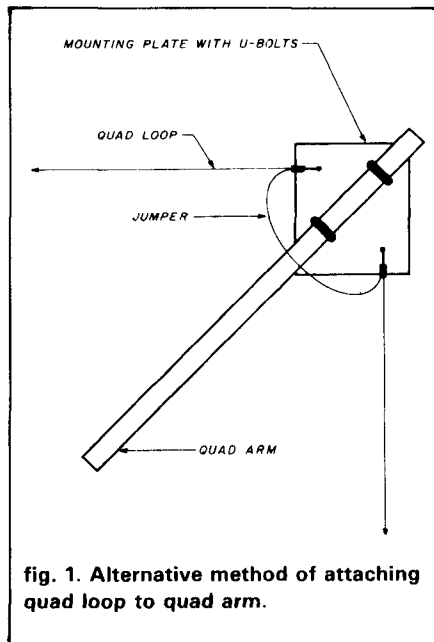

fig. 1. Alternative method of attaching quad loop to quad arm.

Figure 1 shows a novel approach to this problem. An insulating plate (made of fiberglass or formica, for example) is affixed to the quad arm with two U-bolts. The quad wire loop is then attached to holes drilled in the plate and the connection is made as shown in fig. 1. Since I don't have a quad up right now, I can't vouch for the idea, but it looks like a good one, and Amateurs planning to erect quads this spring may be interested in trying out this arrangement.

## the 160-meter antenna at DJ8WL

DJ8WL, who just returned to Germany after three months in Salt Lake City sent me a sketch of the 160-meter antenna he's using in Germany. Those who've heard his signal can attest to the excellence of the antenna design (fig. 2), which he's used since fall, 1984.

His antenna is about 103 feet high (31.4 meters) and is center-loaded by a high-Q coil (L1). A second loading coil is placed at the 19.7 foot (6 meters) level (L2).

Peter uses 50 radials, each 3/8-wave length (205 feet/62.42 meters) long. The feedpoint resistance was measured to be 38 ohms. When only 16 radials were used, the feedpoint resistance was 40 ohms. He estimates his ground resistance to be 9 ohms, so the antenna is about 63 percent efficient.

Antenna response is quite broad, showing less than 1.5:1 SWR over the range of 1800 to 1900 kHz. Peter reports working 9J2JN and LU9EIE the first morning the antenna was on the air!

Peter's antenna was mounted in a tall tree. The top section was made of a fiberglass rod with wire attached, and the lower sections are made of wire. Compared to an inverted-V slung from the same tree at the 80-foot (24.38 meter) elevation, the ground plane produced DX signal reports that were up between 1 to 2 S-units.

DJ8WL's 160-meter DX record with this antenna — as of spring, 1985 — was 135 countries.

## aircraft enhancement of VHF/UHF signals

Why does the 2-meter path between San Francisco and Los Angeles pop open every so often, usually in the evening, for just a few minutes? This interesting opening seems to be duplicated in other parts of the world, apparently on a hit-or-miss basis. Doug McArthur (VK3UM) and Ralph Kettle (VK1RK) noticed strange openings on their path, as well as similar openings to VK2ZAB. Path loss was

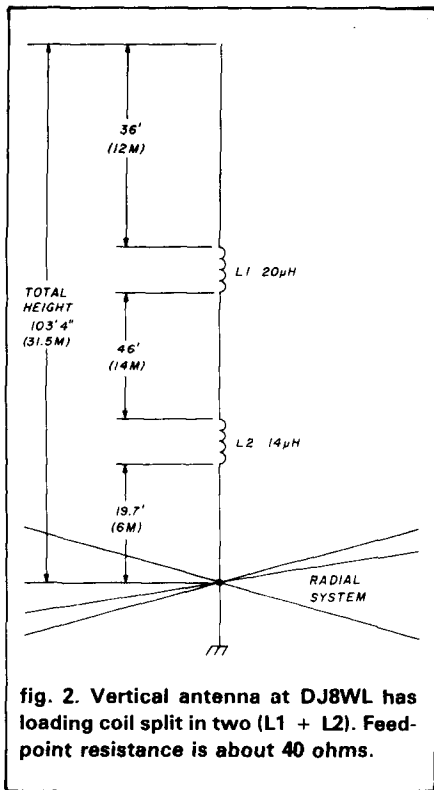

fig. 2. Vertical antenna at DJ8WL has loading coil split in two (L1 + L2). Feed-point resistance is about 40 ohms.

calculated to be  $-245$  dB. The use of medium power, 36-element arrays, and low noise receivers showed that the paths were open for more time than the calculations would indicate. The Melbourne-Canberra path, in particular, had mountainous terrain along the route so direct (i.e., line-of-sight) communication was out of the question, except for occasional tropospheric enhancement. What was causing the strange VHF propagation?

The time of the opening seemed to be related to aircraft passing between the two stations. In particular, two commercial airliners flying from Sydney to Melbourne were midpath at the times of the enhanced propagation.

Upon investigation, it seemed that the height of the flight path and distance of the aircraft from the stations did not tally with the signals received. The signals were too strong and varied markedly with the weather.

VK3UM and his colleagues in the investigation believe that the aircraft are the cause, but not the actual media of the enhanced propagation.

Possible explanations were reflec-

tions caused by the condensation trails ("contrails") left by the aircraft flying at about 30,000 feet, or perhaps refraction caused by the air turbulence wake (temperature effect or vortex turbulence).

The size of the aircraft apparently influenced the enhancement, with the highest level obtained from 747s and DC10s. But even aircraft as small as the Fokker F28 provided a good degree of path enhancement. Multiple aircraft, on the other hand, resulted in multipath effects, making copy difficult.<sup>2</sup>

### some good news?

It's reported in the technical literature that the new AN/TPS-118 over-the-horizon radar under construction in Maine will soon be on the air. It will provide radar detection of planes at ranges from 500 to 1800 miles (804 to 2897 km). The device uses a transmitting antenna more than 3600 feet long and radiates up to 100 Megawatts of power (effective radiated power) in the 5 to 28 MHz frequency range. Two other sites are planned, one covering the Pacific Coast and one in the Midwest to fill in the skip zones of the other two. That adds up to *three* of these giants grinding away in the continental United States. Let's hope they're programmed to stay out of the ham bands!

### a zig-zag dipole antenna

Most compact dipole antennas make use of some form of lumped loading such as an inductor placed in series with the antenna. A few years ago the "zig-zag dipole" was investigated at Hosei University, Tokyo, Japan (fig. 3).

One of the more interesting zig-zag dipoles developed and tested used a 0.5 wavelength wire folded back so that the overall length was about 24 percent less than a full-size dipole. The feedpoint resistance was 46 ohms. The included angle was about 130 degrees and each leg of the configuration was as indicated in fig. 3.

No mention was made of bandwidth, but it seems to me that the

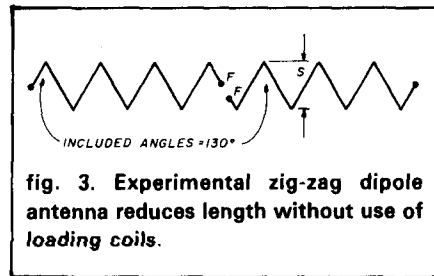

fig. 3. Experimental zig-zag dipole antenna reduces length without use of loading coils.

antenna configuration may provide improved bandwidth because it resembles a "fat" dipole. Some enterprising experimenter should try this antenna on the 80-meter band and see how it performs.

### an inexpensive 160-meter antenna that works

No room for a quarter-wave vertical with 120 radials for 160-meter DX work? Too bad. Join me in crying the blues! About the best I can do is a random-length wire running from the house to my nearby antenna tower. I work it against the residence plumbing system as a ground. Recently I added two 8-foot (2.4 meters) ground rods, one at each end of the house, and tied them to the copper water pipe system. So far, so good.

After I'd been working with various end-fed antenna systems for over six months, the back yard was littered with bits of copper wire. I finally ended up with a wire antenna that worked well, although not quite as well as the antennas the "big guns" were using. But if you share my problem of limited space and don't want to grow an antenna farm, this antenna is ideal for you.

Basically, it's a wire about 155 feet (47.24 meters) long. This makes it longer than a quarter-wavelength at 1.8 MHz (130 feet/39.62 meters). The feedpoint impedance of the longer wire is inductive and slightly higher than that of the quarter-wave wire. The inductive reactance is tuned out by a series-connected capacitor and the feedpoint resistance of the antenna (about 23 ohms) is transformed by a shunt inductor to 50 ohms (fig. 4).

This design provides an inexpensive matching system to provide a 50 ohm

# THE MOST AFFORDABLE REPEATER

ALSO HAS THE MOST IMPRESSIVE PERFORMANCE FEATURES

(AND GIVES THEM TO YOU AS STANDARD EQUIPMENT!)

Band	Kit	Wired
10M,6M, 2M,220	\$680	\$880
440	\$780	\$980



## FEATURES:

- SENSITIVITY SECOND TO NONE; 0.15 uV (VHF), 0.2 uV (UHF) TYP.
- SELECTIVITY THAT CAN'T BE BEAT! BOTH 8 POLE XTAL FILTER & CERAMIC FILTER FOR > 100 dB AT ± 12 KHZ. HELICAL RESONATOR FRONT ENDS TO FIGHT DESENSE & INTERMOD.
- OTHER GREAT RECEIVER FEATURES: FLUTTER-PROOF SQUELCH, AFC TO COMPENSATE FOR OFF-FREQ TRANSMITTERS, SEPARATE LOCAL SPEAKER AMPLIFIER & CONTROL.
- CLEAN, EASY TUNE TRANSMITTER; UP TO 20 WATTS OUT (UP TO 50W WITH OPTIONAL PA).

## HIGH QUALITY XMTR & RCVR MODULES FOR REPEATERS, LINKS, TELEMETRY, ETC.

- **R144/R220 FM RCVRS** for 2M or 220 MHz. 0.15uV sens.; 8 pole xtal filter & ceramic filter in i-f, helical resonator front end for exceptional selectivity, > 100dB at ± 12kHz, best available today. Flutter-proof squelch. AFC tracks drifting xmtrs. Xtal oven avail. Kit only \$138.
- **R451 FM RCVR** Same but for uhf. Tuned line front end, 0.3 uV sens. Kit only \$138.
- **R76 FM RCVR** for 10M, 6M, 2M, or 220. As above, but w/o AFC or hel. res. Kits only \$118. Also avail w/4 pole filter, only \$98/kit.
- **R110 VHF AM RECEIVER** kit for VHF aircraft or ham bands or Space Shuttle. Only \$98.

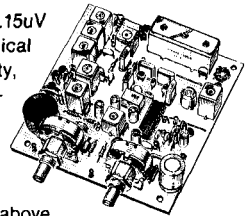

- **T51 VHF FM EXCITER** for 10M, 6M, 2M, or 220 MHz. 2 Watts continuous, up to 3W intermittent. \$68/kit.
- **T451 UHF FM EXCITER** 2 to 3 Watts. Kit only \$78. Xtal oven avail.
- **VHF & UHF LINEAR AMPLIFIERS.** For either FM or SSB. Power levels from 10 to 45 Watts to go with exciters & xmtg converters. Several models. Kits from \$78.

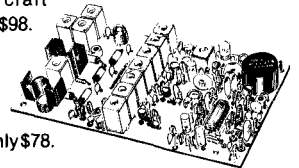

NOW—FCC TYPE-ACCEPTED TRANSMITTERS & RECEIVERS AVAILABLE FOR HIGH-BAND & UHF. CALL FOR DETAILS.

## RECEIVING CONVERTERS

Models to cover every practical rf & if range to listen to SSB, FM, ATV, etc. NF = 2 dB or less.



Antenna Input Range	Receiver Output
28-32	144-148
50-52	28-30
50-54	144-148
144-146	28-30
145-147	28-30
144-144.4	27-27.4
146-148	28-30
144-148	50-54
220-222	28-30
220-224	144-148
222-226	144-148
220-224	50-54
222-224	28-30

### VHF MODELS

Kit with Case	\$49
Less Case	\$39
Wired	\$69

### UHF MODELS

Kit with Case	\$59
Less Case	\$49
Wired	\$75

SCANNER CONVERTERS Copy 806 MHz band on any scanner. Wired/tested ONLY \$88.

## LOW-NOISE PREAMPS

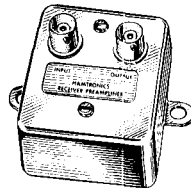

Hamtronics Breaks the Price Barrier!



No Need to Pay \$80 to \$125 for a GaAs FET Preamp.

### FEATURES:

- Very Low Noise: 0.7dB VHF, 0.8dB UHF
- High Gain: 13 to 20dB, Depending on Freq.
- Wide Dynamic Range for Overload Resistance
- Latest Dual-gate GaAsFET, Very Stable

MODEL	TUNES RANGE	PRICE
LNG-28	26-30 MHz	\$49
LNG-50	46-56 MHz	\$49
LNG-144	137-150 MHz	\$49
LNG-160	150-172 MHz	\$49
LNG-220	210-230 MHz	\$49
LNG-432	400-470 MHz	\$49
LNG-800	800-960 MHz	\$49

## MINIATURE PREAMPS

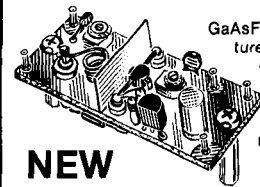

GaAsFET Preamps with features similar to LNG, except designed for LOW COST and SMALL SIZE: only 5/8" W x 1-5/8" L x 3/4" H. Easily mounts inside many radios.

NEW

MODEL	TUNES RANGE	KIT	WIRED
LNW-144	120-150 MHz	\$19	\$34
LNW-160	150-200 MHz	\$19	\$34
LNW-220	200-270 MHz	\$19	\$34
LNW-432	400-500 MHz	\$19	\$34

## IN-LINE PREAMPS

NEW

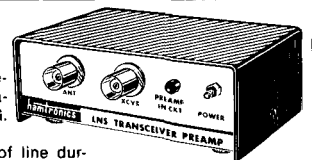

GaAsFET Preamp with features like LNG. Automatically switches out of line during transmit. Use with base or mobile transceivers up to 25W. Tower mtg hdwr incl.

MODEL	TUNES RANGE	KIT	WIRED
LNS-144	120-150 MHz	\$68	\$98
LNS-160	150-180 MHz	\$68	\$98
LNS-220	200-240 MHz	\$68	\$98
LNS-432	400-500 MHz	\$68	\$98

## ACCESSORIES

- **MO-202 FSK DATA MODULATOR.** Run up to 1200 baud digital or packet radio signals through any FM transmitter.
- **DE-202 FSK DATA DEMODULATOR**
- **COR-2 KIT** With audio mixer, local speaker amplifier, tail & time-out timers.
- **COR-3 KIT** with "courtesy" beep".
- **DTMF DECODER/CONTROLLER KITS**
- **AUTOPATCH KITS.** Provide repeater autopatch, reverse patch, phone line remote control of repeater, secondary autopatch.
- **CWID KITS** • **SIMPLEX AUTOPATCH**

## TRANSMIT CONVERTERS

For SSB, CW, ATV, FM, etc. Why pay big bucks for a multi mode rig for each band? Can be linked with receive converters for transceive. 2 Watts output vhf, 1 Watt uhf.

For VHF, Model XV2  
Kit \$79  
Wired \$149  
(Specify band)

Exciter Input Range	Antenna Output
28-30	144-146
28-29	145-146
28-30	50-52
27-27.4	144-144.4
28-30	220-222*
50-54	220-224
144-146	50-52
50-54	144-148
144-146	28-30

For UHF, Model XV4  
Kit \$99  
Wired \$169

Exciter Input Range	Antenna Output
28-30	432-434
28-30	435-437
50-54	432-436
61.25	439.25
144-148	432-436*

VHF & UHF LINEAR AMPLIFIERS. Use with above. Power levels from 10 to 45 Watts. Several models, kits from \$78.

## HELICAL RESONATOR PREAMPS

Low-noise preamps with helical resonators reduce intermod and cross-band interference in critical applications. 12 dB gain.

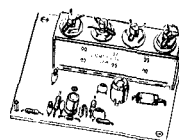

Model	Tuning Range	Price
HRA-144	143-150 MHz	\$49
HRA-220	213-233 MHz	\$49
HRA-432	420-450 MHz	\$59
HRA-( )	150-174 MHz	\$54
HRA-( )	450-470 MHz	\$64

- Send \$1 for Complete Catalog (Send \$2.00 or 4 IRC's for overseas mailing)
- Order by phone or mail • Add \$3 S & H per order (Electronic answering service evenings & weekends)
- Use VISA, MASTERCARD, Check, or UPS COD.

# hamtronics, inc.

65-E MOUL ROAD • HILTON NY 14468

Phone: 716-392-9430

Hamtronics® is a registered trademark

feedpoint, required by today's modern transceivers. The solid-state amplifiers are not very forgiving with respect to oddball antenna feedpoint impedances, and operation of the 160-meter band stretches the capability of the solid-state amplifier, even under the best conditions.

But this antenna solves that problem. You can change the antenna length and compensate for it with the variable capacitor. As the antenna is shortened toward the quarter wavelength point, the capacitor value increases. As the antenna approaches three-quarter wave resonance, the value of the capacitor diminishes. A happy medium is reached when the antenna is about 0.275 wavelength long. If the inductor and capacitor are variable, the operator can scoot from one end of the band to the other in just a few seconds.

Operational bandwidth of the antenna is quite good; an SWR of better than 1.5:1 can be maintained over 50 kHz without touching the network controls. I tune up at 1825 kHz and am able to QSY up and down 25 kHz at the touch of the transceiver dial.

How well does it work? Well, I'll let you know the results after the next 160-meter DX contest! So far, it seems to be the best wire I've ever had on the "low band."

### building the tuner

You can build the tuner on a metal chassis and panel, but it's not necessary (see photo A). My tuner is built on a plywood base with a micarta™ panel. The unit is 8 x 8 inches (25 x 25 x 25 cm). I recommend using a vernier drive on the capacitor because the setting for lowest SWR is quite sharp. The setting of the shunt inductor, on the other hand, is less critical and the counter dial is a luxury. The 3 ampere RF thermocouple meter is very handy for tuneup, so if you can find one at a flea market, buy it and use it. I short mine out with a clip lead after tuneup to keep the meter from jumping around when I'm transmitting.

### the 80-40 meter antenna at CN2AQ

Have you heard the strong signal of CN2AQ on 80 meters? He has an

antenna that doubles as a telephone line! Look at fig. 5. The 328 foot (99.91 meter) wire runs between two buildings. RF chokes at each end of the

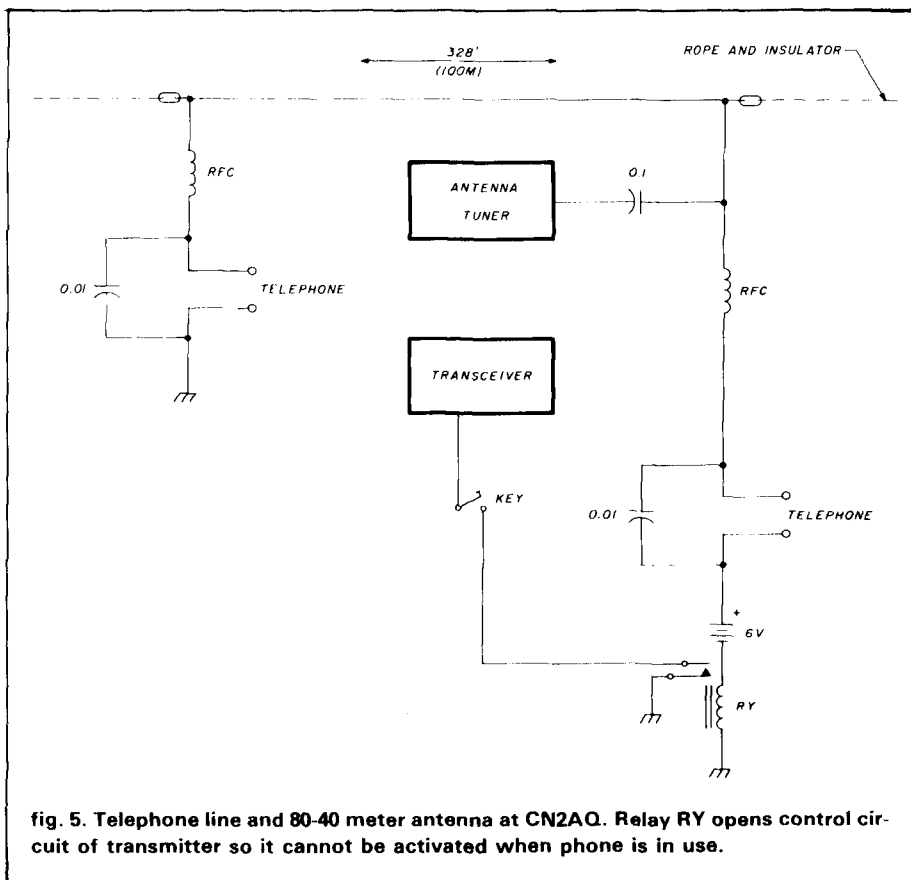
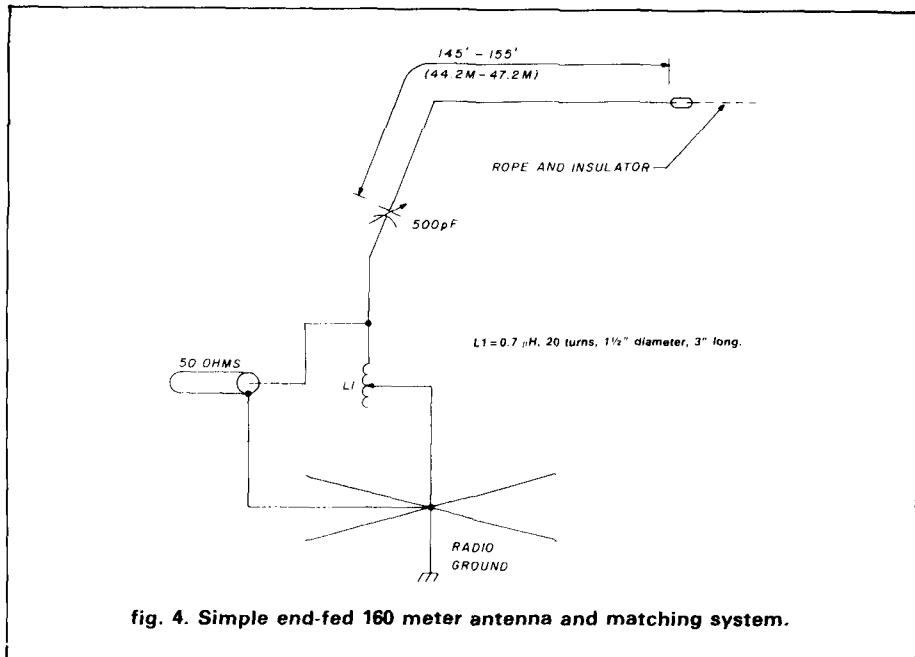

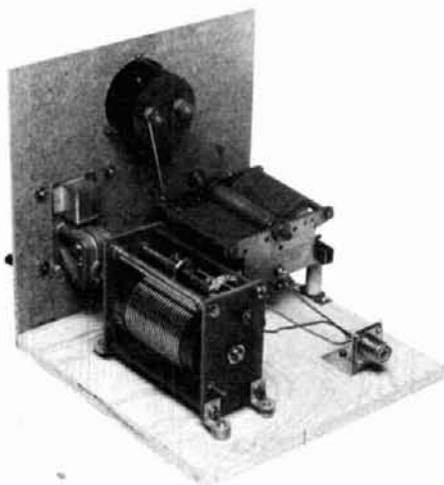

Photo A. W6SAI tuner is built on plywood base.

wire isolate it for the telephone service, in which the return circuit is via ground. In order to prevent the transmitter from being activated when the telephone circuit is in use, a series-connected relay opens the control circuit of the exciter. Now, that seems to be a very practical idea!

### what about your antenna?

The sunspot cycle is at low ebb and interest is growing in the 160 and 80-meter bands. I would be interested in hearing about *your* antenna for the low bands. Please send the information to me, care of *ham radio* magazine; the most interesting antennas will be discussed in this column. I hope to hear from you!

#### references

1. *Amateur Radio*, Journal of the Wireless Institute of Australia, May, 1985.
2. *Amateur Radio*, Journal of the Wireless Institute of Australia, July, 1985.
3. Nakano, Tagami and Yoshizawa, "Shortening Ratios of Modified Dipole Antennas," *IEEE Transactions on Antennas and Propagation*, Volume AP 32, No. 4, April 1984.

### ham radio

#### Invitation to Authors

*ham radio* welcomes manuscripts from readers. If you have an idea for an article you'd like to have considered for publication, send for a free copy of the *ham radio* Author's Guide. Address your request to *ham radio*, Greenville, New Hampshire 03048 (SASE appreciated).

# CUT YOUR LOSSES

Portable radios can be a trade-off. In return for mobility you get loss of performance.

Well now you can cut your losses significantly. All you need is the new Larsen UHF KūLDUCKIE® KD14-HW half-wave antenna.\* It's a mouthful but it'll do your ears a lot of good.

Because it's half-wave, the KD14-HW is fully resonant despite the poor ground plane portables are faced with. Under ideal ground plane conditions, it delivers performance equal to a full quarter-wave. And that's a powerful improvement over most portable antennas!

And because it is inherently resonant, the KD14-HW can also be easily removed with a length of coax.

The KD14's flexible, easy-to-get-along-with radiating element measures a scant 12 inches. At the base is a 3/4 inch impedance transformer that gives added strength.

The KD14 half-wave series is also available in a collapsible 2-meter version.

Cut your losses and improve your gain when you operate with the new Larsen UHF KūLDUCKIE® KD14-HW, with no-nonsense warranty. You can see it at your favorite amateur dealer.

\*For units with BNC output.



## Larsen Antennas

The Amateur's Professional™

See your favorite amateur dealer or write for a free amateur catalog.

IN USA: Larsen Electronics, Inc. / 11611 N.E. 50th Ave. / P.O. Box 1799 / Vancouver, WA 98668 / 206-573-2722  
IN CANADA: Canadian Larsen Electronics, Ltd. / 149 West 6th Ave. / Vancouver, B.C. V5Y 1K3 / 604-872-8517

LARSEN® KūLROD® AND KūLDUCKIE® ARE REGISTERED TRADEMARKS OF LARSEN ELECTRONICS, INC.



# EME link calculator program

Maximize your  
station's performance  
with knowledge  
of tradeoffs

## In trying to set up an EME (moonbounce) station

I found it difficult to make trade-offs in terms of antenna gain, coax line losses, preamplifier placement, and output power. What I needed was an easy way to weigh the different parameters against each other. Looking through a few books, I found what I was looking for in the *ARRL Handbook*, the *RSGB VHF-UHF Manual* and in an article by R. Lentz.<sup>1,2,3</sup>

By taking pieces of information from all three sources, I was able to figure out how to vary all the station information in order to calculate the link budget signal-to-noise ratio. However, it became apparent that getting answers by punching buttons on my hand calculator would take a few nights. Also, I was mixing up the answers and station data so much that I couldn't figure out what answer belonged to what station data. Figuring that there had to be a better way, I looked for a computer program to do the job. Not finding one, I wrote the BASIC program included in this article (fig. 1). I used Microsoft BASIC for the IBM PC, so it should be able to run as is or with little modification on other PCs or compatibles.

After the requested data is entered, the program provides signal-to-noise ratio (SNR), effective isotropic radiated power (EIRP), and the system noise temperature. Using these figures, you can change the input parameters and see how to best assemble your EME system. With the computer doing most of the work, it's easy to use real numbers, rather than using whatever is convenient, as I did with the calculator.

Both the ARRL and the RSGB handbook examples placed the receive preamplifier at the antenna. They then set the line loss at a convenient zero dB. Since no-loss coax phasing lines don't exist, those example calculations don't really show you what is happening in an antenna array. On the other hand, the program shows that even a 0.5 dB phasing line loss will have a significant effect on the performance at 432 MHz. The computer program provides performance infor-

mation about an EME station while allowing you to easily change all the station parameters.

## realistic data is needed

The data requested by the program is generally familiar. The only data I had trouble figuring out was the sky temperature, which is the actual sky temperature the antenna sees. Don't confuse it with the array temperature, which is sometimes given in antenna articles. Try about 10 to 35 degrees Kelvin for 432 MHz and around 175 to 200 degrees Kelvin for 144 MHz.<sup>4</sup> (Use the lower numbers if your system is in the country and the higher numbers if you live in or near an urban area). At low elevations the antenna will see the earth at 290 degrees Kelvin. This program assumes you're looking high enough with your antenna so that the antenna's main and side lobes clear the earth. After a little practice with the program, you can set the sky temperature higher; this will demonstrate earth effects on EME communications at moon rise or moon set. I left the bandwidth as a variable. Most of the time it should be set at 100 Hz, as the ear and mind can provide that much filter capability. You can set the bandwidth to 1800 Hz to see what kind of signal is required for EME SSB.

The program doesn't provide absolute answers. You can't take an existing station, enter its data into the program, and come out exactly with the way the system works. The real world, after all, includes other factors such as Faraday rotation, noise from you don't know where, and systems built not quite the way they should be. The real benefit of the program is to show the relative merit (or lack of merit) of different ways of putting together an EME station. For instance, what's the benefit of running 1.5 kW instead of 800 Watts? How much better is a 0.3 dB noise figure preamp than a 0.6 dB preamp? Does it make any difference if you use Belden 9913 for phasing lines instead of RG-213/U? Try it and see — you may be surprised.

## program structure

The program is divided into six parts: constants, data input, calculations, screen output results, print results and program end. **Lines 10 to 35** contain the program header and set up constant values. **Lines 30 and 35** provide a log to base 10 function as most BASICs have only a log to the base e function. **Lines**

By David Engle, KE6ZE, 1063 Summerwood Court, San Jose, California 95132

```

10 ' Program to calculate signal to noise ratios for EME operations.
11 '     David Engle, KE6ZE           September 1985
12 '
20 K = 1.38E-23 ' Boltzman's constant.
25 TL=290.0 ' Temperature of receive feed line.
30 LOG10E=.434294482 'is log to the base 10 of e.
35 DEF FNLOG10(V)=LOG(V) * LOG10E ' Log to base 10 function
100 ' Get data to set up calculations.
110 PRINT" EME Signal to Noise calculator program" : PRINT
120 INPUT" ENTER FREQUENCY, MHz: ",FREQ
130 INPUT" ENTER TX ANTENNA GAIN, dBi: ",GT
140 INPUT" ENTER TX OUTPUT POWER, WATTS: ",P
150 INPUT" ENTER TX LINE LOSS, dB: ",LT
160 INPUT" ENTER RX ANTENNA GAIN, dBi: ",GR
170 INPUT" ENTER RX LINE LOSS, dB: ",LL
180 INPUT" ENTER RX NOISE FIGURE, dB: ",RN
190 INPUT" ENTER RX BANDWIDTH, Hz: ",B
200 INPUT" ENTER SKY TEMPERATURE, Deg K: ",SKY
210 PRINT
300 'Start calculations.
310 'Transmitter power.
320 PO = 10.0 * FNLOG10(P)
340 'Receiver noise level.
350 TR=((10.0^(RN/10.0)) -1.0 ) * 290.0 'Noise figure to noise temp
360 LR = 10.0^(LL/10.0) ' Noise figure (dB) to noise factor.
370 TS = SKY + ((LR - 1)* TL) + (LR * TR)
380 PN = 10.0 * FNLOG10(K*TS*B)
390 'Path loss.
400 PL = 8.72 * LOG (432/FREQ) - 261
410 'Signal to noise.
420 SNR = PO - LT + GT + PL + GR - PN
430 BAND% = INT (FREQ)
440 EIRP =INT (P*10^((GT-LT)/10.0))
500 'Display the results.
510 PRINT"Transmit EIRP =";EIRP;"Watts,";
520 PRINT" System Noise Temp =";(INT (TS));"Degrees K."
530 PRINT" Signal-to-noise ratio at:"," Perigee","Mid.,","Apogee."
540 PRINT" for ";BAND%;"MHz band is:", SNR, SNR-1, SNR-2
550 PRINT
600 'Print the results.
610 OPEN "LPT1:" FOR OUTPUT AS #1
620 PRINT#1,
630 PRINT#1,"FREQUENCY =";FREQ;"MHz"
640 PRINT#1,"TX ANTENNA GAIN =";GT;"dBi,";
650 PRINT#1," TX OUTPUT POWER =";P;"Watts,";
660 PRINT#1," TX LINE LOSS =";LT;"dB"
670 PRINT#1,"RX ANTENNA GAIN =";GR;"dBi,";
680 PRINT#1," RX LINE LOSS =";LL;"dB"
690 PRINT#1,"RX NOISE FIGURE =";RN;"dB,";
700 PRINT#1," RX BANDWIDTH =";B;"Hz"
710 PRINT#1,"SKY TEMPERATURE =";SKY;"Deg K"
720 PRINT#1,
730 PRINT#1,"Transmit EIRP =";EIRP;"Watts,";
740 PRINT#1," System Noise Temp =";(INT (TS));"Degrees K."
750 PRINT#1,"Signal-to-noise ratio at:"," Perigee","Mid.,","Apogee."
760 PRINT#1," for ";BAND%;"MHz band is:", SNR, SNR-1, SNR-2
770 PRINT#1,
780 CLOSE #1
900 INPUT" Do you wish to continue? (Y/N) ",ANS$
910 IF ANS$="Y" OR ANS$="y" THEN 120

```

fig. 1. EME station optimization program listing.

Frequency = 144 MHz  
 TX Antenna Gain = 21 dBi, TX Output Power = 1500 Watts,  
 TX Line Loss = 0.5 dB

RX Antenna Gain = 21 dBi, RX Line Loss = 0.5 dB

RX Noise Figure = 0.5 dB, RX Bandwidth = 100 Hz

Sky Temperature = 170 Deg K

Transmit EIRP = 168302 Watts, System Noise Temp = 245  
 Degrees K.

Signal-to-noise ratio at:	Perigee,	Mid.,	Apogee
for 144 MHz band is:	6.548783	5.548783	4.548783

fig. 2A. Typical data displayed in run of SNR program.

100 to 210 inquire and retrieve the station data from the operator (you). Lines 300 to 440 do the calculations and come up with the answers. Line 350, which converts the preamplifier gain in dB to noise temperature, is from the RSGB manual. Line 360 converts the receiver (preamplifier) line loss into a ratio.<sup>3</sup> Line 400 provides the path loss. (The path loss is an approximation — a little high at 50 MHz, right on at 432 MHz, and a little low at 2304 MHz. All are within 1 dB.) Lines 500 to 550 display the answers on your screen. Lines 600 to 780 print both the input data and the answers on your line printer. If you have no printer, omit lines 600 to 780. Line 610 sets the printer up. If your computer calls its printer something other than "LPT1," you'll have to change this line accordingly. Lines 900 to 999 re-run or end the program.

### sample run checks program

Figure 2A contains a set of data to run through the program after you get it entered in the computer. This can be used to check the accuracy of what you've typed in. If you don't get the answers listed to within 0.1 dB, exit the program by answering "N" to the question, "Do you wish to continue?" You should still be running BASIC at this point, so you can look at the intermediate answers from the program. Simply type "PRINT PO," "PRINT PL," and those values will be printed on the screen. Any of the intermediate values used in the program (e.g., PO, TR, LR, TS, PN, PL, SNR) may be looked at in this manner. Figure 2B contains the set of intermediate values generated during the fig. 2A example. If your answers are different from these examples, then you have an error in one of the previous lines that works on that variable.

I hope this program can help you demystify the optimization of your EME station. A couple of the more interesting things I noticed were the effects of phasing line loss and preamplifier noise figure on the

PO = 31.760  
 TR = 35.385  
 LR = 1.122  
 TS = 245.088  
 PN = -184.708  
 PL = -251.420  
 SNR = 6.548

fig. 2B. Intermediate values generated for fig. 1 results.

system's performance. These effects are easily noticed in the system noise figure. Fire it up and plug in your numbers. It may be easier to improve your system than you think!

### references

1. Charles Hutchinson, K8CH, Editor, *The ARRL 1985 Handbook for the Radio Amateur*, American Radio Relay League, Newington, Connecticut, 62nd Edition, Chapter 23, pages 11 and 12.
2. D.S. Evans, G3RPE, and G.R. Jessop, G6JP, Editors, *VHF-UHF Manual*, Radio Society of Great Britain, London, 3rd Edition, Chapter 9, pages 12 to 14.
3. R. Lentz, DL3WR, "Noise in Receive Systems," *VHF Communications*, 4/1975, pages 217 to 235.
4. Steve Powlisken, K1FO, "Stacking Yagis Is A Science," *ham radio*, May, 1985, pages 18 to 23.

### ham radio

## One source for amateur radio books, tapes and computer programs.

# PROPAGATION PUBLISHING

Over 125 books, tapes and computer programs to keep you up to date in the ham world, or to help you upgrade for that new ticket. ■ Send your name and address for a FREE copy of the new Propagation Publishing catalog.

### SPECIAL!

#### "Flying Horse" 1986 Callbooks

The new ones with the biggest change in callbook history! Now all of North America, with US possessions, in one book.

- North American Callbook Postpaid in USA \$21.95
- International Callbook Postpaid in USA \$20.95

Please send check or money order. Illinois residents please add 6% sales tax.

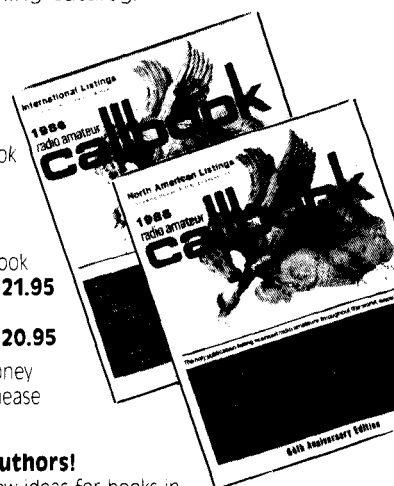

### We are looking for authors!

We want authors with new ideas for books in the amateur radio field. If you have a book in work or just thinking about one, send an outline and sample chapter to us for review. We can give your book the national exposure needed to make it a success.

**PROPAGATION PUBLISHING**  
 PO Box 5255, Morton, Illinois 61550

# ham radio

## Reader Service

For literature or more information, locate the Reader Service number at the bottom of the ad, circle the appropriate number on this card, affix postage and send to us. We'll hustle your name and address to the companies you're interested in.

101 113 125 137 149 161 173 185 197 209 221 233 245 257 269 281 293 305 317 329 341  
102 114 126 138 150 162 174 186 198 210 222 234 246 258 270 282 294 306 318 330 342  
103 115 127 139 151 163 175 187 199 211 223 235 247 259 271 283 295 307 319 331 343  
104 116 128 140 152 164 176 188 200 212 224 236 248 260 272 284 296 308 320 332 344  
105 117 129 141 153 165 177 189 201 213 225 237 249 261 273 285 297 309 321 333 345  
106 118 130 142 154 166 178 190 202 214 226 238 250 262 274 286 298 310 322 334 346  
107 119 131 143 155 167 179 191 203 215 227 239 251 263 275 287 299 311 323 335 347  
108 120 132 144 156 168 180 192 204 216 228 240 252 264 276 288 300 312 324 336 348  
109 121 133 145 157 169 181 193 205 217 229 241 253 265 277 289 301 313 325 337 349  
110 122 134 146 158 170 182 194 206 218 230 242 254 266 278 290 302 314 326 338 350  
111 123 135 147 159 171 183 195 207 219 231 243 255 267 279 291 303 315 327 339  
112 124 136 148 160 172 184 196 208 220 232 244 256 268 280 292 304 316 328 340

*Limit 15 inquiries per request.*

NAME \_\_\_\_\_ CALL \_\_\_\_\_

ADDRESS \_\_\_\_\_

CITY \_\_\_\_\_ STATE \_\_\_\_\_ ZIP \_\_\_\_\_

Please use before March 31, 1986

**February 1986**



AFFIX POSTAGE  
OR  
POST OFFICE  
WILL NOT  
DELIVER

***ham***  
***radio***  
*magazine*

READER SERVICE CENTER  
P.O. BOX 2558  
WOBURN, MA 01888

ATTN: Reader Service Dept.



# COLORADO COMM CENTER

## KENWOOD



### TR-2600

2.5W/300MW (swt) / 400MHz 2-Meter hand-held Transceiver  
• LCD Readout  
• 10 Memories w/ Lift-up Back-up  
• Band and Memory Scan



### TH-21AT

• Compact Pocket Size  
• 1-Watt  
• 0 Pr. 500 M.A. Battery

### TH-2570



• First 70 Watt FM Mobile Autodialer • 23 Channel Memory • Front Panel Programmable CTCSS



### TS-940S "DX-celence"

• Programmable Scanning  
• High Stability Dual Digital VFO's  
• 40 Channel Memory  
• General Coverage Receiver

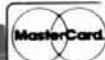

800-227-7373

- AEA
- ALINCO
- ASTRON
- AVANTI
- B&W
- BENCHER
- BUTTERNUT
- CUSHCRAFT
- DAIWA
- HAM-KEY
- HUSTLER
- HYGAIN
- ICOM
- KANTRONICS
- KDK
- KENPRO
- KENWOOD
- KLM
- LARSEN
- MFJ
- MIRAGE
- NYE VIKING
- QUATRON
- SANTEC
- WELZ
- YAESU

**COD'S WELCOME**

## YAESU



### FT-209RH

• 5 Watts  
• 10 Memories  
• LCD  
• Compact

### FT-2700R

• Duo-Band Full Duplex  
• 25 Watt



### FRG-9600



• 100 Memories  
• 60 MHz - 905 MHz Continuous



4262 Lowell Blvd. • Denver, Co. 80211 • 433-3355

✓ 167

33 cm. • 23 cm. • 13 cm.



### LOOP YAGIS AND AMPLIFIERS FROM DOWN EAST MICROWAVE

• TROPO • WEAK SIGNAL  
• EME • OSCAR MODE L & MODE S  
• 902 • 1269 • 1296 • 2304 • 2400 MHz

2345LY 45 el loop Yagi 1296 MHz 20 + dBi \$85  
2445LY 45 el loop Yagi 1269 MHz 20 + dBi \$75  
1345LY 45 el loop Yagi 2304 MHz 20 + dBi \$75  
3333LY 33 el loop Yagi 902 MHz 18.5 dBi \$85

above antennas are assembled and tested.  
All aluminum and stainless construction. Kits also available.  
Add \$8 (\$11 west of Rockies) per antenna for UPS shipping.

2 & 4 way power dividers, complete arrays available  
2316 PA Linear Amp 1w in 18w out 1296 MHz 13.5 V \$230  
2335 PA Linear Amp 10w in 36w out 1296 MHz 13.5 V \$280  
include \$5 for UPS Blue — 48 states.

Write about Higher Power, 2304 lines, GaAs Fet preamps  
Free catalog

### DOWN EAST MICROWAVE

Bill Olson, W3HOT  
Box 1655A, RFD 1, Burnham, ME 04922  
(207) 948-3741

✓ 157

## NEW Alpha Delta Model DX-A 160-80-40 METER QUARTER WAVE TWIN SLOPER ANTENNA

The Model DX-A combines the tremendous firepower of the quarter wave sloper with the wide bandwidth of a half wave dipole. Simple to install, quick to tune. Proven longhaul DX performance.

- Installs like an inverted-V dipole. One leg for 80 meters (67') and the other leg for 160/40 meters (55'). Fed with a single 50 ohm coax. SO-239 connector provided on mounting bracket.
- Configuration provides wide bandwidth on all three bands. Typically 70 kHz on 160 meters, 200 kHz on 80 meters and full band on 40 meters. Much wider than most other loaded slopers, dipoles or verticals. Tuner usually not required.
- Model DX-A also operates on 30-17-12 meters. VSWR of less than 2.5:1. Easily matched with a tuner.
- High-power operation. Rated at 1500 watts P.E.P. output. No traps to break

- down. A single "ISO-RES" isolator-resonator is used in the 160/40 meter leg.
- Current lobe up high for maximum radiation and excellent DX performance. Can be installed from 25 to 40' high.
- The Model DX-A Antenna is fully assembled, uses all stainless steel hardware, a UV-protected "ISO-RES" coil, #12 copper wire and is rated for severe environments. Specially coated wire disappears from your neighbors' view.

**\$49<sup>95</sup>** Available from your local Alpha Delta Dealer or add \$4.00 shipping and handling (USA only).

**ALPHA DELTA COMMUNICATIONS, INC.**

P.O. Box 571 Centerville, OH 45459  
(513) 435-4772 Orders • (513) 376-4180 Antenna Tech Info



current solutions to current problems

**ASTRON — SALE!**

RS-7A	45.00	RS-35A	123.75
RS-12A	62.75	RS-35M	138.95
RS-12M	78.95	VS-35M	156.95
RS-20A	79.95	RS-50A	179.95
RS-20M	96.45	RS-50M	203.25
VS-20M	114.95	VS-50M	223.95

**KLM**

2M16LBX,220-22LBX,432-30LBX-90.50	
2M-14C-85.50	2M-22C-108.50
435-18C-110.90	435-40CX-144.50

**KENPRO ROTORS**

KR400/KR500	125.95/154.95
KR-5400/KR-5600	247.90/309.95

**HENRY AMPS**

2 KD CLASSIC	965.00
2002A/2004A Less Relay	1250./1350.
3002A/3004A Less Relay	2100./2100.

**AMP SUPPLY**

LK-500ZB	1,097.95
LK-800A	2,045.00

**MIRAGE-FREE UPS BROWN ON ALL MIRAGE**

A1015 - 235.50	C-22A - 85.95
B23A - 83.95	C-106 - 169.95
B215 - 245.50	C-1012 - 246.95
B108 - 149.95	D-24N - 177.50
B1016 - 235.50	D-1010N - 279.50
B3016 - 199.50	D-3010N - 251.00
MP-1 - 99.95	MP-2 - 99.95

**TONNA 9F8T ANTENNAS ARE BACK! WE ARE THE EXCLUSIVE U.S. DISTRIBUTOR INTRODUCTORY SPECIAL:**  
1269/1296 QUAD ARRAY COMPLETE WITH 4-23el YAGIS, 'H' FRAME, POWER DIVIDER, PHASING LINES, CONNECTORS, TERRESTRIAL APPLICATIONS. REGULARLY 339.95 SALE PRICE 215.95

**OTHER GREAT, HIGH PERFORMANCE ANTENNAS BY TONNA (CALL FOR SPEC. SHEET!!)**

5 EL. 6 METER YAGI	69.95	13 EL. 2MTR YAGI	59.95	<b>TONNA(CALL FOR SPEC. SHEET!!)</b>	
21 EL. 70cm YAGI	56.95	23 EL. 1296/69 YAGI	46.95	19 EL. 70cm YAGI	44.95
(ATV MODELS IN STOCK)		17 EL. 2MTR SUPER YAGI	88.00	2MTR OSCARTWIST	65.95
70cm OSCARTWIST	68.95	55 EL. 1296 SUPER YAGI	68.95	2 x 9 EL. (18el)	
2 x 19 EL. (38el.)		9 ± 19 el OSCAR ANTENNA 2M & 70cm ON A COMMONBOOM-GREAT FOR STACKING.	75.92		

**WATCH OUR AD FOR NEW LINES!!**

**FOR THE BEST DEAL IN TOWN CALL THE BEST NUMBER AROUND 1-800-HAM-7373**

**CUSHCRAFT AOP-1 OSCAR PAK-133.99 RINGO RANGER II (2-220-440)-33.99**  
**KENWOOD TS-940S/AT - CALL US! YAESU FT-757GX - CALL US!**  
**KENWOOD TR2600A H.T. - CALL US! YAESU FT-726R - CALL US!**

**KENWOOD**  
FACTORY AUTHORIZED DEALER  
CALL US FOR AMERICA'S LOWEST PRICE ON ALL YOUR KENWOOD NEEDS  
(FREE UPS BROWN KENWOOD GEAR)

**CUSHCRAFT**

215WB - 73.00	A-3	200.45
4218XL - 91.00	A-4	267.45
R-3 - 250.95	40-2CD	267.45

OTHER MODELS IN STOCK — CALL

**CUE DEE THE SWEDISH BOOMER**  
USED BY MANY TOP '10' CONTESTERS  
144-15AN 2MTR15EL. 75.95

**PARABOLIC**

1296-28 IW TRANSVERTER	339.95
1269-144 3W UP CONV.	319.95
1296 DUAL TUBE AMP CAVITY	439.95
2PORT POWER DIVIDERS (2-220-432)	50.95
4PORT POWER DIVIDERS (2-220-432)	55.95
1296 2PORT DIVIDER	57.95
1296 4PORT DIVIDER	62.95
1269/96 DISH FEEDS	89.95
2304 DISH FEEDS	89.95
1296 SLUG TUNERS	65.95

**YAESU — FACTORY AUTHORIZED DEALER CALL FOR THE BEST DEAL AROUND ON 'THE RADIO' FULL LINE (FREE UPS BROWN ON YAESU GEAR)**

**MUTEK LTD.**  
DO YOU OWN AN ICOM VHF XCUR? DO YOU WANT TO IMPROVE THE RECEIVER - TRY OUR MUTEK FRONT END BOARD - YOU'LL BE GLAD YOU DID!  
RPCB211/251 RD FRONT END 143.95  
FOR ICOM 211 OR 251  
RPCB271 FRONT END FOR 168.95  
ICOM 271A OR 271H  
RPCB225 FRONT END FOR 143.95  
YAESU 221/225  
SLNA 50S 6MTR PREAMP 84.95  
SLNA-144S 2MTR PREAMP 84.95  
100WRF SWITCHED, N.F. < ldb, GAIN 15db  
SBLA144E 2MTR MAST MOUNT R.F. SWITCHED PREAMP, 250W THRU POWER, N.F. < ldb 15db 169.95  
GLNA 433E 70CM MAST MOUNT R.F. SWITCHED PREAMP, 50W THRU N.F. < ldb G = 15db 172.95  
GFBA-144E 2MTR MAST MT. PREAMP, 1KW THRU POWER G = 15db N.F. < 8db WITH AMP SEQUENCER 289.95  
GLNA-432E 70cm MAST MT. PREAMP, 500W THRU, G = 15db N.F. < ldb. WITH AMP SEQUENCER 299.95  
HIGH D.R. DBM XVRTRS FOR 6 ± 2MTRS COMING SOON!

**SSB ELECTRONIC**

K6001 6 To 10 DBM RCV CONV.	115.95
K2001 2 To 10 DBM RCV CONV.	115.95
K7001 70cm To 10 DBM RCV CONV.	115.95
K2301G 23cm To 10 or 2 RCV CONV. G.F. FRONT END AND DBM	159.95
TV-144-28-10 10W 2MTX XVRTR	209.95
TV-432-28-10 10W 70cm XVRTR	299.95
TV-220-28-10 10W 1 1/4M XVRTR Coming Soon	
DX-144 PREAMP N.F. < 4db	130.95
DX-220 PREAMP N.F. < 5db Coming Soon	
DX-432 PREAMP N.F. < 5db	130.95
(WON DAYTON 1985 N.F. CONTEST)	
DX-1296S PREAMP N.F. 5db	156.95
DX-2320 PREAMP N.F. < 8db	166.95
PA-2310 1269/1296 10W LINEAR AMP	275.95
LT-235 1296 10W LINEAR TRANSVERTER	610.95
2MIF	610.95
LSM-24 1269-2 OSCAR MODE L XMIT CONV. 1W	
OUTPUT, 2M I.F.	299.95
MICROLINE 13 1/2W 2.3GHZ XVRTR SYSTEM 2M I.F.	610.95
MICROLINE 13 3W 2.3GHZ XVRTR SYSTEM 2M I.F.	675.95
SLA-13 2304 3W AMP	285.95

**MAST MOUNTED PREAMPS:**  
MV144V 250W R.F. SWITCH WITH 12V SUPPLY INTERFACE 175.95  
MV432V 150W R.F. SWITCH WITH INTERFACE 185.95  
MV-144S-01 1KW THRU PWR WITH SEQUENCER 309.95  
MV-432S-01 500W THRU PWR WITH SEQUENCER 319.95  
MV-1296S 100WTHRU PWR WITH SEQUENCER 349.95  
OTHER HIGH QUALITY PRODUCTS IN STOCK-CALL FOR CATALOGUE

**GREAT FOR OSCAR MODE 'L' OR** 215.95

**TERMS:** Prices do not include shipping except where indicated and are subject to change without notice. At our discretion some COD's may require a deposit. Returns are subject to a 15% restocking charge. \*Continental USA only

16 S. Mountain Blvd — Rt. 309 HOURS: Monday thru Friday 9 a.m. - 3:30 p.m. "24 HOUR PHONE SERVICE MC/VISA/C O D  
Mountaintop, Pa. 18707 Saturdays 10 a.m. - 12 p.m. FOR YOUR CONVENIENCE!"

**PACKET PICK-IT**

**AEA** PK-64 \$199.00  
HFM-64 \$ 99.00

**NEW** PK-80 \$199.00

**Kantronics**  
KANTRONICS PACKET COMMUNICATOR \$199.00

**MFJ**  
MFJ 1270 PACKET \$115.00

**GO PACKET!**  
**FM of the 80's**

**MADISON**  
**Electronics Supply**

3621 FANNIN  
HOUSTON, TEXAS 77004  
1-713-520-7300 OR 1-713-520-0550

**PRC**

**SERVICE CENTER**  
for  
**ICOM, KENWOOD**  
and **YAESU**

*HAS YOUR WARRANTY GONE SOUTH?*  
When you're in need of service, you can rely on our factory trained experience in Amateur, Marine and Land Mobile.

"Write or phone, you'll be pleasantly surprised by our professional approach to your service needs".

Bob, KG7D

FCC NABER Lic  
Mon-Fri 10:00-4:00 pm  
(206) 776-8993

**PACIFIC RIM COMMUNICATIONS**  
23332 58th Ave. West  
Mountlake Terrace, Wa 98043

VISA & C.O.D.S Welcome 124

**MAKE CIRCUIT BOARDS THE NEW, EASY WAY**

**WITH TEC-200 FILM**

**JUST 3 EASY STEPS:**

- Copy circuit on TEC-200 film using any plain paper copier
- Iron film on to copper clad board
- Peel off film and etch

**SATISFACTION GUARANTEED**  
convenient 8 1/2 x 11 size

**5-Sheets for \$3.95**  
**10 sheets only \$5.95**  
add \$1.00 postage — NY res. add sales tax

**The MEADOWLAKE Corp.**  
Dept. M, P.O. Box 497  
Northport, New York 11768

# John J. Meshna Jr., Inc.

P. O. Box 62 19 Allerton St. E. Lynn, Ma. 01904 Tel: (617) 595-2275

## COMPUTER TERMINAL BUILDING BLOCK \$50.00

This is a great beginning for a computer terminal. It is a brand new, Panasonic, 9" TTL input monitor complete with its own self-contained, switching power supply, and a removeable (four screws) triple output power supply. The whole assembly runs on 115/230 V, 50/60 Hz. Now for some specifics: 9" green phosphor, TTL input monitor, attached regulated 12 VDC, 1.5 A power supply used exclusively to run the monitor and an attached triple output switching power supply with outputs of 5 VDC @ 3.5 A, +12 VDC @ 500 ma, and -12 VDC @ 500 ma. The assembly has mounting feet and should be a snap to make a case for. Comes with hook up data. New, factory boxed. We are offering this to you 4 ways:

- COMPLETE SET-UP AS SHOWN, including monitor, low voltage supply and triple output supply. SPL-116-38, 14 Lbs., \$50.00, 5/\$225.00
- TRIPLE OUTPUT SUPPLY ONLY, SPL-117-38, 3 Lbs. \$15.00
- 9" MONITOR ONLY, (you supply low voltage input) SPL-114-38, 10 Lbs. \$25.00
- 9" MONITOR W/LOW VOLTAGE SUPPLY ONLY, SPL-115-38, 12 Lbs. \$40.00

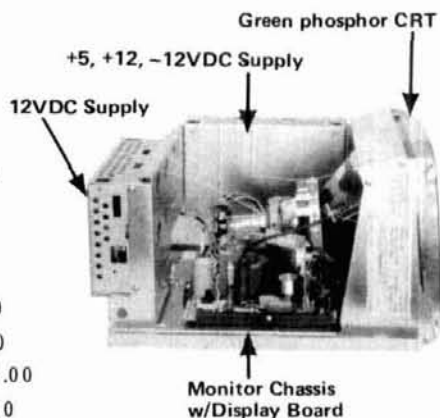

We are now selling guaranteed working, starlight scopes which allow sight in almost total darkness. They are so named because they incorporate a light amplification tube which uses the available star or moon light to allow you to see - without being seen. The scope has a spectral response of 4,500 to 8,000 angstroms, resolution of 50 lines/mm, viewing area of 25mm, standard 50mm F1.4 lens, optional telephoto 135mm F2.8 lens, cross hair reticle and optional carrying case. A great tool for security and naturalist applications. Runs on 9VDC transistor radio battery. Due to the nature of this device and people only having a one time use for it, we cannot accept returns for refund, credit or exchange on this item. To our knowledge, this is the least expensive starlight scope on the market. Includes 90 day warranty.

<b>STARLIGHT SCOPE</b>	<b>SPL-130A-39</b>	<b>\$1,200.00</b>
Optional Telephoto Lens, 135mm F2.8	SPL-131A-39	\$85.00
Optional Fitted Carrying Case	SPL-132A-39	\$65.00

### ATTENTION:

**SECURITY PERSONNEL  
NATURALISTS  
HOBBYISTS**

**NEW SEE-IN-THE-DARK EQUIPMENT!**



### 5 1/4" HARD DRIVE CONTROLLER CARD

Finally, affordable, intelligent disc drive controllers are available at low, low surplus prices. The OMTI 20C controller boards we offer are unused, late style, surplus from a now defunct system house. OMTI is a division of Scientific Micro Systems. These boards will handle up to (2) 5 1/4 inch Winchester type hard drives that utilize a standard 34 pin SASI interface. Perfect for using with the above Seagate ST 506 drive, or other hard drives from 5 megabytes of storage on up. The controllers have buffered slew/seek modes, overlapped seeks, auto seek & verify, extensive fault detection, auto head & cylinder switching, full sector buffering, 256/512 bytes/sector, 33 or 18 sectors/track (jumper selectable), programmable disc parameters and much more. The board runs on +5 vdc & +12 vdc.. We supply users manual & pinout data. Guaranteed O. K.. Shpg. wt. 3 lb. OMTI 20 C \$150.00 each 2/\$275.00 Qty. pricing available.



### HIGH POWER SURVEILLANCE IR SCOPE

This Infra-Red scope was designed specifically for long range surveillance use. The built-in, totally invisible, 50 watt halogen lamp IR source is coupled with a premium grade type 6032 image converter tube, 265 mm f4.2 lens, and 16 power military spec., color corrected eyepiece make this an ideal unit for viewing of clandestine activities or animals. The scope is capable of detection at more than 300 feet, recognition at 300 feet and positive facial identification at 150 feet. It runs on 12 VDC which makes it ideal for mobile use. It comes with a removeable hand grip which allows for tripod mounting, 2 power cords for cigarette lighter or battery terminals, instructions and a 90 day warranty. Listed below are accessories which make this a very versatile instrument. The scope and accessories are new and guaranteed functional. Net wt. 5-1/4 Lbs.

IR Scope part no. ELD Shpg. Wt. 7 Lbs. \$735.00 ea.

#### ACCESSORIES:

12 VDC GELL BATTERY for above. Shpg. Wt. 6 Lbs. \$35.00

BIOCULAR EYEPIECE which can be used in place of the standard eyepiece. This allows the scene being produced by the IR viewer to be seen by the operator up to 4 ft. away. 2 Lbs. \$89.95

MALE "T" f1.6 CAMERA DAPTER for SLR cameras Shpg. Wt. 1 Lb. \$129.00

MALE "C" to FEMALE "T" ADAPTER for CCTV, requires use of above male "T" f1.6 adapter. Shpg. Wt. 1 Lb. \$29.95

Free 72 page catalogue available or send \$1.00 for 1st class service to P. O. Box 62 E. Lynn, Ma. 01904.

Phone (617) 595-2275 to place your order by phone. MC, VISA, or American Express charge cards accepted.



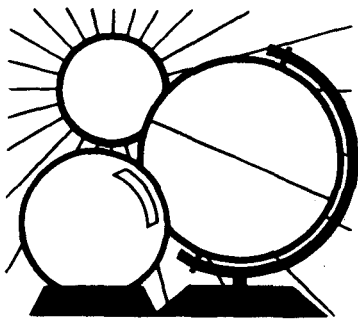

# DX FORECASTER

Garth Stonehocker, KØRYW

## sunspots and MUFs

Because we're nearing the 11-year sunspot number minimum, the Institute for Telecommunication Science study comparing MUF distribution of values for low, medium, and high sunspot numbers should be of interest. **Table 1** (similar to last month's) lists the ratios of the 10- and 90-percentile monthly median MUF values. The data is separated into day and night groups over three solar activity ranges: low (68-88) sunspots in the years 1954-55; medium (90-115) in the years 1961-62; and high (200-285) in the years 1957-58 at various control point latitudes. The upper decile values (90 percent) use the column head + % and the lower decile (10 percent) by - % in the table. A separate listing is provided for daytime and nighttime periods.

Notice that greater deviations from median occur in the high (70 degree) and low (10 degree) latitudes in all sunspot categories regardless of whether it's local daytime or nighttime. However, the largest deviations occur during a high sunspot number year and at night. This increased MUF is from the solar flare particles arriving via the solar wind at the polar ionosphere down the open geomagnetic field lines from the sun (see the geomagnetic field drawing in "DX Forecaster," June, 1985, page 102) on the day side of the earth. On the night side the particles come into the ionosphere from the stored particle areas (Van Allen belts) along the closed and tail geomagnetic field lines.

The exception to the foregoing pattern is the 20-degree latitude night values at low and medium sunspot numbers. Here the geomagnetic variations help the ions drift upward along the closed field lines until within 20 degrees of the geomagnetic equator. This is a winter nighttime effect during medium to low sunspot numbers. Here again is evidence of trans-equatorial DX propagation; it is accompanied by an F-region trough (with low MUFs) just south of the auroral zone. The low MUFs in the trough are shown by the large - % numbers at 70 degrees latitude during the night. The increased geomagnetic variability during low to medium sunspot numbers results from a stronger solar wind stream through a thinning

solar corona while the sun is yet somewhat active. This data, the MUF distribution statistical trends of propagation effects, can be used to understand and improve DX operating skills.

## last minute forecast

The best DX conditions for the higher frequency bands are expected during the first and last weeks of February. The solar flux base level should increase about 5 units in January and February. So look for some increase in MUFs in the midlatitudes as last month's table showed. Trans-equatorial propagation should be good and enhanced by some geomagnetic disturbances around the 10th and 24th of the month. The lower frequency bands are expected to be very good

table 1. Variation in the ratio of monthly median MUF values.

Latitude	Sunspot Range	- % Day	+ %	- % Night	+ %
70	Low	22	23	28	29
	Medium	24	29	23	30
	High	26	29	27	30
50	Low	19	15	21	21
	Medium	21	17	21	21
	High	22	22	21	18
30	Low	17	17	22	26
	Medium	19	17	24	25
	High	14	17	18	18
20	Low	21	19	26	31
	Medium	18	19	27	34
	High	12	14	21	26
10	Low	14	18	26	27
	Medium	15	17	25	27
	High	12	15	20	25



**WESTERN USA**

GMT	WESTERN USA							
	PST	N	NE	E	SE	S	SW	NW
0000	4:00	30*	40	20	10	12	10	10
0100	5:00	20	40	20	10	12	10	10
0200	6:00	20	40	20	12	12	10	10
0300	7:00	30	40	20	15	12	10	12
0400	8:00	30	40	20	20*	12	15	15
0500	9:00	40	40	30	20	15	15	20
0600	10:00	40	40	30	20	20*	20	20
0700	11:00	40	40	30	20	20	20	20
0800	12:00	40	40	30	20	20	20	20
0900	1:00	40	40	30	20	20	20	20
1000	2:00	40	40	30	20	20	20	20
1100	3:00	40	40	30	20	20	20	20
1200	4:00	40	40	30	20	20	20	20
1300	5:00	40	30	15	20	30	30	20
1400	6:00	40	20	12	15	30	30	20
1500	7:00	40	20	10	12*	20	20	20
1600	8:00	40	20	10	10	15	20	20
1700	9:00	40	20	10	10	12	20	20
1800	10:00	40	20	10	10	12	20*	20
1900	11:00	40	20	10	10	12	15	20
2000	12:00	40	30	12*	10	12	12	15
2100	1:00	40	40*	12	10	12	12	15
2200	2:00	40	40	15	10	12	10	12
2300	3:00	40	40	15	10	12	10	12

**MID USA**

GMT	MID USA							
	MST	N	NE	E	SE	S	SW	NW
0000	5:00	40	40	20	10	12	10	10
0100	6:00	30	40	20	12	12	10	12
0200	7:00	30	40	20	15	12	12	15
0300	8:00	30	40	20	15	15	15	20
0400	9:00	40	40	20	20	20*	15	20
0500	10:00	40	40	30	20	20	20	20
0600	11:00	40	40	30	20	20	20	20
0700	12:00	40	40	30	20	20	20	20
0800	1:00	40	40	30	20	20	20	20
0900	2:00	40	40	30	20	20	20	20
1000	3:00	40	40	30	20	20	20	20
1100	4:00	40	30	15	30	30	30	20
1200	5:00	40	20	12	20	20	30	20
1300	6:00	40	20	10	15	20*	20	20
1400	7:00	40	20	10	12*	15	20	20
1500	8:00	40	20	10	10	15	20	20
1600	9:00	40	20	10	10	15	20	20
1700	10:00	40	20	10	10	12	20	20
1800	11:00	40	20	10	10	12	15	20
1900	12:00	40	20	10	10	12	15	20
2000	1:00	40	30	12*	10	12	12	15
2100	2:00	40	40*	12	10	12	12	15
2200	3:00	40	40	15	10	12	10	12
2300	4:00	40	40	15	10	12	10	12

**EASTERN USA**

GMT	EASTERN USA							
	EST	N	NE	E	SE	S	SW	NW
0000	7:00	40	40	20	12	12	12	12
0100	8:00	40*	40	20	15	12	15	15
0200	9:00	40	40	20	15	15	20	20
0300	10:00	40	40	20	20	20*	20	20
0400	11:00	40	40	20	20	20	20	20
0500	12:00	40	40	30	20	20	20	20
0600	1:00	40	40	30	20	20	20	20
0700	2:00	40	40	30	20	20	30	20
0800	3:00	40	40	30	20	20	30	20
0900	4:00	40	40	30	20	20	30	20
1000	5:00	40	30	15	30*	30	30	20
1100	6:00	40	20	12	20	30	30	20
1200	7:00	40	20	10	15	20	30	20
1300	8:00	40	20	10	12	15	20	20*
1400	9:00	40	20	10	12	15	20	20
1500	10:00	40	20	10	10	15	20	20
1600	11:00	40	20	10	10	12	20	20
1700	12:00	40	20	10	10	12	20	20
1800	1:00	40	20	10	10	12	15	20
1900	2:00	40	20	10	10	12	15	20
2000	3:00	40	30	12*	10	12	12	15
2100	4:00	40	40	15	10	12	12	15
2200	5:00	40	40	15	10	12	10	12
2300	6:00	40	40	20	10	12	10	12

The italicized numbers signify the bands to try during the transition and early morning hours, while the standard type provides MUF during "normal" hours.  
 \*Look at next higher band for possible openings.



## Measure Up With Coaxial Dynamics Model 83500 Digital Wattmeter

The "Generation Gap" is filled with the "new" EXPEDITOR, the microprocessor based R.F. AnaDigit System. The EXPEDITOR power computer...you make the demands, it fills the requirements.

- Programmable forward AND reflected power ranges.
- Can be used with the elements you now have.
- Compatible with all Coaxial Dynamics line sizes and power ranges.
- 18 scales from 100 mW to 50 kW.

Contact us for your nearest authorized Coaxial Dynamics representative or distributor in our world-wide sales network.



**COAXIAL  
DYNAMICS, INC.**

15210 Industrial Parkway  
Cleveland, Ohio 44135  
216-267-2233 1-800-COAXIAL  
Telex: 98-0630

*Service and Dependability...A Part of Every Product*



throughout the month, but especially good around mid-month.

No significant meteor showers occur during February. The full moon is on the 2nd and lunar perigee is on the 4th.

### band-by-band summary.

*Ten, twelve, fifteen, and twenty meters* will be open from morning to early evening almost every day, and to most areas of the world. The openings on the higher of these bands will be shorter — to the southern hemisphere — and will occur closer to local noon. Transequatorial propagation on these bands will more likely occur toward evening during conditions of highest solar flux and a disturbed geomagnetic field.

*Thirty and forty meters* will be useful almost 24 hours a day. Daytime conditions will resemble those on 20 meters, except that skip distances and signal strength may decrease during midday on days that coincide with the higher solar flux values. Nighttime DX will be good except after days of high MUF conditions and during geomagnetic disturbances. Look for DX from unusual places on east, north, and west paths during daytime and southern paths at night. The usable distance is expected to be somewhat less than 20 in daytime and greater than on 80 at night.

*Eighty and one-sixty meters* will exhibit short-skip propagation during daylight hours and lengthen for DX at dusk. These bands follow the darkness regions opening to the east just before your sunset, swinging more to the north-south near midnight and ending up in the Pacific areas during the hour or so before dawn on the path of your interest. The 160-meter band opens later and ends earlier than the 80-meter band.

ham radio

**SAY YOU SAW IT  
IN  
HAM RADIO**

✓ 168

## POPULAR PA 19 Wideband Preamp

- Over 8,000 sold since 1976
- 0.5 - 200 MHz bandwidth
- 19 dB gain\*
- 50 Ω in/output
- Increase sensitivity of receivers or counters
- Built, tested & ready-to-go

**ONLY \$9.95 PPD**

## NEW POCKET SIZED 500 MHz Freq. Counter

- Compact design-pocket sized
- Measures frequency from 1 MHz to 500 MHz to within 1 kHz
- Built-in telescoping antenna
- Uses 1 standard 9 volt battery
- All units pre-tested and calibrated to .001%
- Professional and dependable performance at a low cost



**ONLY \$49.95 PPD**

✓ 158

**DIGITREX  
1005 BLOOMER  
ROCHESTER, MI 48063  
WEST COAST DISTRIBUTOR  
R. LUKASZEWICZ**

20610 ALAMINOS DRIVE SAUGUS, CA 91350  
(805) 252-6021

## MULTI BAND TRAP ANTENNAS



### TRAP DIPOLES:

Model	Bands	Traps	Length	Price
D-42	10/15/20/40	2	55	\$59.95
D-52	10/15/20/40/80	2	105	64.95
D-56	10/15/20/40/80	6	99	109.95

### TRAP VERTICALS - "SLOPERS":\*

Model	Bands	Traps	Length	Price
VS-31	10/15/20	1	12	42.95
VS-41	10/15/20/40	1	27	44.95
VS-52	10/15/20/40/80	2	52	59.95
VS-53	10/15/20/40/80	3	49	69.95

\*Can be used without radials.  
\*Feed line can be buried if desired.

\*Permanent or Portable Use

ALL ANTENNAS are Ready to use - Factory assembled - Commercial Quality - Handle full power - Comes complete with Deluxe Traps, Deluxe center connector, 14 ga Stranded CopperWeld ant wire and End Insulators. Automatic Band Switching - Tuner usually never required - For all transmitters, Receivers & Transceivers - For all class amateurs - One feedline works all bands - Instructions included - 10 day trial!

### COAX CABLE: (includes PL-259 connector on each end)

Type	Length	With antenna purchase	Separately
RG-58	50	\$8.00	\$11.95
RG-58	90	12.00	16.95

### DELUXE CENTER CONNECTOR

- NO RUST Brass Terminals
- NO jumper wires used
- NO Soldering
- Built in Lightning Arrestor
- With SO-239 Receptacle
- Handles Full Power
- Completely sealed, weatherproof
- Easy element adjustments
- Commercial quality



ORDER DIRECT FROM FACTORY. All orders shipped US Postpaid  
VISA/MC give card #, Exp. date, Signature



**SPI-RO MANUFACTURING, INC.**  
Room 103, P.O. Box 1538  
Hendersonville, NC 28793



Dealer Inquiries Invited

✓ 113

THE STANDARDS OF EXCELLENCE

# SUPERIOR WEAK SIGNAL PERFORMANCE COMMERCIAL MODEM

## COMPARE with ANY unit at ANY Price

Now Available With  
PACKET RADIO

THE WORLD OF VHF/HF PACKET\*,  
CW, RTTY, ASCII AND NEW DUAL  
AMTOR\*\* IS AS CLOSE AS YOUR  
FINGERTIPS WITH THE BRILLIANTLY  
INNOVATIVE STATE-OF-THE-ART  
MICRO-COMPUTER CONTROLLED  
EXL-5000E.

SPECIAL SALE

**\$649**

With Packet Radio — \$795



SHOWN WITH OPTIONAL PACKET TNC

Everything built in — nothing else to buy!

- AUTOMATIC SEND/RECEIVE—ANY SPEED ANY SHIFT • BUILT IN COMPUTER GRADE 5" MONITOR • EXTERNAL MONITOR JACK • TIME CLOCK ON SCREEN • TIMED TRANSMISSION AND RECEIVING • SELCAL • CRYSTAL CONTROLLED AFSK MODULATOR • PHOTOCOUPLER CW, FSK KEYS • ASCII KEY ARRANGEMENT • 15 CHANNEL BATTERY BACK-UP MEMORY • 1,280 CHARACTER DISPLAY MEMORY • SPLIT SCREEN TYPE-AHEAD BUFFER • FUNCTION SCREEN DISPLAY • PARALLEL PRINTER INTERFACE • SPEEDS: CW 5-100 WPM (AUTOTRACK), 12-300 BAUD (ASCII AND BAUDOT); 12-600 BAUD TTL; 100 BAUD ARQ/FEC AMTOR • ATC • RUB-OUT FUNCTION • AUTOMATIC CR/LF • WORD MODE • LINE MODE • WORD WRAP AROUND • ECHO • TEXT CURSOR CONTROL • USOS • DIDDLE • TEST MESSAGES (RY AND QBF) • MARK AND BREAK (SPACE AND BREAK) SYSTEM • VARIABLE CW WEIGHTS • AUDIO MONITOR CIRCUIT BUILT IN • CW PRACTICE FUNCTION • CW RANDOM GENERATOR • BARGRAPH LED METER FOR TUNING • OSCILLOSCOPE OUTPUTS • BUILT IN 100-120 / 220-240 VAC 50/60HZ AND 13.8VDC POWER SUPPLIES • AND MUCH, MUCH MORE • SIZE: 14W x 14D x 5H • 1 YEAR LIMITED WARRANTY •



SPECIAL SALE \$249

### Θ-777 THE MOST ADVANCED COMPUTER INTERFACE EVER DESIGNED FOR COMMERCIAL AND AMATEUR USE.

RTTY, BIT INVERSION (RTTY), ASCII, AMTOR (MODE A (ARQ), MODE B (FEC AND SEL-FEC), MODE L), CW, ANY SPEED ANY SHIFT (ASCII AND BAUDOT)\*

- AUTO DECODING: Automatically decodes signal and displays mode, speed and polarity on the CRT — **COMPARE!**
- 28 BAR-LED'S and LED'S plus a Bar-Graph Tuning Indicator indicate function, mode, and status — **COMPARE!**
- The awesome power of the Θ-777 is limited only by the imagination of the user and the terminal program of the computer.
- Use with Any computer that has RS232 or TTL I/O, IBM, Apple, Commodore, TRS80, etc.

**Everything Built In - Including Software — Nothing Else To Buy!**

- \*SPEEDS: CW 5-100 WPM (AUTOTRACK), 12-200 BAUD (ASCII AND BAUDOT); 12-600 BAUD TTL, AND RS232 OR TTL LEVEL DATA CONNECTION - 100-2400 BAUD (ASCII) OR 45.5-200 BAUD (BAUDOT) • SELCAL • MEMORY: 15 CHANNELS +768 CHARACTER INPUT BUFFER • AUTO PTT • CW ID • DIDDLE • USOS • ECHO • AUTO CR/LF • ATC • RUB-OUT • CW PRACTICE GENERATOR • VARIABLE CW WEIGHTS • TEST MESSAGE (RY AND QBF) • FULL CRT FUNCTION DISPLAY • MARK - AND - BREAK (SPACE - AND -BREAK) SYSTEM • XTAL AFSK • AUDIO MONITOR • OSCILLOSCOPE OUTPUTS • AND MUCH, MUCH MORE • POWER SUPPLY REQUIREMENTS: 13.8 V DC, 700MA • SIZE: 9W x 10D x 2½H • 1 YEAR LIMITED WARRANTY •

EXCLUSIVE DISTRIBUTOR: DEALER INQUIRIES INVITED FOR YOUR NEAREST DEALER OR TO ORDER:  
**AMATEUR-WHOLESALE ELECTRONICS TOLL FREE...800-327-3102**  
8817 S.W. 129th Terrace, Miami, Florida 33176 Telephone (305) 233-3631 Telex: 80-3356

MANUFACTURER:  
**TONO CORPORATION**  
98 Motosoja Machi, Maebashi-Shi, 371, Japan

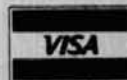

\*PLEASE CALL FOR DETAILS

\*\*Dual Amtor: Commercial quality, the EXL-5000E incorporates two completely separate modems to fully support the amateur Amtor codes and all of the CCIR recommendations 476-2 for commercial requirements.

Specifications Subject to Change.



HF Equipment	Regular	SALE
IC-735 HF transceiver/SW rcvr/mic	849.00	729 <sup>95</sup>
PS-55 External power supply	160.00	144 <sup>95</sup>
AT-150 Automatic antenna tuner	349.00	314 <sup>95</sup>
FL-32 500 Hz CW filter	59.50	
EX-243 Electronic keyer unit	50.00	
IC-745 9-band xcvr w/1.30 MHz rcvr	999.00	769 <sup>95</sup>
PS-35 Internal power supply	160.00	144 <sup>95</sup>
EX-241 Marker unit	20.00	
EX-242 FM unit	39.00	
EX-243 Electronic keyer unit	50.00	
FL-45 500 Hz CW filter (1st IF)	59.50	
FL-54 270 Hz CW filter (1st IF)	47.50	
FL-52A 500 Hz CW filter (2nd IF)	96.50	89 <sup>95</sup>
FL-53A 250 Hz CW filter (2nd IF)	96.50	89 <sup>95</sup>
FL-44A SSB filter (2nd IF)	159.00	144 <sup>95</sup>
HM-10 Scanning mobile microphone	39.50	
SM-6 Desk microphone	39.00	
HM-12 Extra hand microphone	39.50	
MB-12 Mobile mount	19.50	



IC-751 9-band xcvr/1.30 MHz rcvr	1399.00	1089
PS-35 Internal power supply	160.00	144 <sup>95</sup>
FL-32 500 Hz CW filter (1st IF)	59.50	
FL-63 250 Hz CW filter (1st IF)	48.50	
FL-52A 500 Hz CW filter (2nd IF)	96.50	89 <sup>95</sup>
FL-53A 250 Hz CW filter (2nd IF)	96.50	89 <sup>95</sup>
FL-33 AM filter	31.50	
FL-70 2.8 kHz wide SSB filter	46.50	
HM-12 Extra hand microphone	39.50	
SM-6 Desk microphone	39.00	
RC-10 External frequency controller	35.00	
MB-18 Mobile mount	19.50	

IC-720A 9-band xcvr • (CLOSEOUT) •	1349.00	699 <sup>95</sup>
PS-15 20A external power supply	149.00	134 <sup>95</sup>
FL-32 500 Hz CW filter	59.50	
FL-34 5.2 kHz AM filter	49.50	
BC-10A Memory back-up	8.50	
SM-5 8-pin electret desk mic	39.00	
MB-5 Mobile mount	19.50	

Other Accessories:	Regular	SALE
PS-15 20A external power supply	149.00	134 <sup>95</sup>
CF-1 Cooling fan for PS-15	45.00	
EX-144 Adaptor for CF-1/PS-15	6.50	
PS-30 Systems p/s w/cord, 6-pin plug	259.95	234 <sup>95</sup>
OPC Opt. cord, specify 2, 4 or 6-pin	5.50	
SP-3 External base station speaker	49.50	
SP-5 Remote speaker for mobiles	25.00	
CR-64 High stab. ref. xtal (745/751)	56.00	
PP-1 Speaker/patch (specify radio)	139.00	129 <sup>95</sup>
SM-8 Desk mic - two cables, Scan.	69.95	
AT-100 100W 8-band auto. antenna tuner	349.00	314 <sup>95</sup>
AT-500 500W 9-band auto. antenna tuner	449.00	399 <sup>95</sup>
AH-1 5-band mobile antenna w/tuner	289.00	259 <sup>95</sup>
GC-4 World clock • (CLOSEOUT) •	99.95	79 <sup>95</sup>



HF linear amplifier	Regular	SALE
IC-2KL 160-15m solid state amp w/ps	1795.00	1299
6-meter VHF Portable	Regular	SALE
IC-505 3/10W 6m SSB/CW portable	449.00	399 <sup>95</sup>
BP-10 Internal Nicad battery pack	79.50	
BP-15 AC charger	12.50	
EX-248 FM unit	49.50	
LC-10 Leather case	34.95	
VHF/UHF base multi-modes	Regular	SALE
IC-551D 80W 6-meter SSB/CW	699.00	599 <sup>95</sup>
EX-106 FM option	125.00	112 <sup>95</sup>
BC-10A Memory back-up	8.50	
SM-2 Electret desk microphone	39.00	
IC-271A 25W 2m FM/SSB/CW	699.00	569 <sup>95</sup>
AG-20 Internal preamplifier*	56.95	
IC-271H 100W 2m FM/SSB/CW	899.00	759 <sup>95</sup>
AG-25 Mast mounted preamplifier*	84.95	
IC-471A 25W 430-450 SSB/CW/FM xcvr	799.00	699 <sup>95</sup>
AG-1 Mast mounted preamplifier*	89.00	
IC-471H 75W 430-450 SSB/CW/FM	1099.00	969 <sup>95</sup>
AG-35 Mast mounted preamplifier*	84.95	

**For a Limited time!**  
 With the purchase of an IC-271A/H or IC-471A/H get the matching PREAMP\* for only • \$1.00 Extra.

Accessories common to 271A/H and 471A/H	Regular	SALE
PS-25 Internal power supply for (A)	99.00	89 <sup>95</sup>
PS-35 Internal power supply for (H)	160.00	144 <sup>95</sup>
PS-15 External power supply	149.00	134 <sup>95</sup>
SM-6 Desk microphone	39.00	
EX-310 Voice synthesizer	39.95	
TS-32 CommSpec encode/decoder	59.95	
UT-15 Encoder/decoder interface	12.50	
UT-15S w/TS-32 installed	79.95	

VHF/UHF mobile multi-modes	Regular	SALE
IC-290H 25W 2m SSB/FM, TTP mic	549.00	479 <sup>95</sup>
IC-490A 10W 430-440 SSB/FM/CW	649.00	579 <sup>95</sup>

VHF/UHF/1.2 GHz FM	Regular	SALE
IC-27A Compact 25W 2m FM w/TTP mic	369.00	299 <sup>95</sup>
IC-27H Compact 45W 2m FM w/TTP mic	409.00	359 <sup>95</sup>
IC-37A Compact 25W 220 FM, TTP mic	449.00	329 <sup>95</sup>
IC-47A Compact 25W 440 FM, TTP mic	469.00	399 <sup>95</sup>
PS-45 Compact 8A power supply	112.95	99 <sup>95</sup>
UT-16/EX-388 Voice synthesizer	29.95	
SP-10 Slim-line external speaker	29.95	
IC-3200A 25W 2m/440 FM w/TTP	549.00	489 <sup>95</sup>
UT-23 Voice synthesizer	29.95	
AH-32 2m/440 Dual Band antenna	32.95	
Larsen PO-K Roof mount	20.00	
Larsen PO-TLM Trunk-lip mount	20.18	
Larsen PO-MM Magnetic mount	19.63	
IC-1271A 10W 1.2 GHz SSB/CW Base	999.00	889 <sup>95</sup>
ATV-1200 ATV interface unit	TBA	
PS-25 Internal power supply	99.00	89 <sup>95</sup>
EX-310 Voice synthesizer	39.95	
UT-15S CTCSS encoder/decoder	79.95	
IC-120 1W 1.2 GHz FM Mobile	499.00	449 <sup>95</sup>
ML-12 1.2 GHz 10W amplifier	339.00	299 <sup>95</sup>

Repeaters	Regular	SALE
RP-3010 440 MHz, 10W FM, xtal cont.	999.00	899 <sup>95</sup>
RP-1210 1.2 GHz, 10W FM, 99 ch. synth	1199.00	1089
Duplexer 1210 1.2 GHz duplexer	1199.00	1089
Cabinet for RP-1210	249.00	



**Order Toll Free**  
**Use your Credit Card!**

Hand-held Transceivers	Regular	SALE
Deluxe models		
IC-02AT for 2m	349.00	289 <sup>95</sup>
IC-04AT for 440 MHz	379.00	319 <sup>95</sup>
Standard models	Regular	SALE
IC-2A for 2m	239.50	189 <sup>95</sup>
IC-2AT with TTP	269.50	199 <sup>95</sup>
IC-3AT 220 MHz, TTP	299.95	239 <sup>95</sup>
IC-4AT 440 MHz, TTP	299.95	239 <sup>95</sup>

Accessories for Deluxe models	Regular	SALE
BP-7 425mah/13.2V Nicad Pak - use BC-35	67.50	
BP-8 800mah/8.4V Nicad Pak - use BC-35	62.50	
BC-35 Drop in desk charger for all batteries	69.00	
BC-60 6-position gang charger, all batts	359.95	SALE
BC-16U Wall charger for BP7/BP8	10.00	
LC-11 Vinyl case	17.95	
LC-14 Vinyl case for Dlx using BP-7/8	17.95	
LC-02AT Leather case for Dlx models w/BP-7/8	39.95	

Accessories for both models	Regular	SALE
BP-2 425mah/7.2V Nicad Pak - use BC35	39.50	
BP-3 Extra Std. 250 mah/8.4V Nicad Pak	29.50	
BP-4 Alkaline battery case	12.50	
BP-5 425mah/10.8V Nicad Pak - use BC35	49.50	
CA-2 Telescoping 2m antenna	10.00	
CA-5 5/8-wave telescoping 2m antenna	18.95	
FA-2 Extra 2m flexible antenna	10.00	
CP-1 Cig. lighter plug/cord for BP3 or Dlx	9.50	
DC-1 DC operation pak for standard models	17.50	
LC-2AT Leather case for standard models	34.95	
RB-1 Vinyl waterproof radio bag	30.00	
HH-SS Handheld shoulder strap	14.95	
HM-9 Speaker microphone	34.50	
HS10 Boom microphone/headset	19.50	
HS-10SA Vox unit for HS-10 & Deluxe only	19.50	
HS-10SB PTT unit for HS-10	19.50	
ML-1 2m 2.3w in/10w out amplifier	79.95	SALE
SS-32M Commspec 32-tone encoder	29.95	

Receivers	Regular	SALE
R-7000 25-2000 MHz, 117V AC	899.00	789 <sup>95</sup>
RC-12 Infrared remote controller	TBA	
R-71A 100 kHz-30 MHz, 117V AC	\$799.00	649 <sup>95</sup>
RC-11 Infrared remote controller	59.95	49 <sup>95</sup>
FL-32 500 Hz CW filter	59.50	
FL-63 250 Hz CW filter (1st IF)	48.50	
FL-44A SSB filter (2nd IF)	159.00	144 <sup>95</sup>
EX-257 FM unit	38.00	
EX-310 Voice synthesizer	39.95	
CR-64 High stability oscillator xtal	56.00	
SP-3 External speaker	49.50	
CK-70 (EX-299) 12V DC option	9.95	
MB-12 Mobile mount	19.50	



**HOURS • Mon. thru Fri. 9-5:30; Sat. 9-3**  
 Milwaukee WATS line: 1-800-558-0411 answered evenings until 8:00 pm Monday thru Thursday.  
**Please use WATS lines for Ordering**  
 use Regular lines for other Info and Service dept.

All Prices in this list are subject to change without notice.

**Order Toll Free: 1-800-558-0411** In Wisconsin (outside Milwaukee Metro Area) 1-800-242-5195

# AMATEUR ELECTRONIC SUPPLY<sup>®</sup> Inc.

4828 W. Fond du Lac Avenue; Milwaukee, WI 53216 - Phone (414) 442-4200

## AES BRANCH STORES

<b>WICKLIFFE, Ohio</b> 44092 28940 Euclid Avenue Phone (216) 585-7388 Ohio WATS 1-800-362-0290 Outside Ohio 1-800-321-3594	<b>ORLANDO, Fla.</b> 32803 621 Commonwealth Ave. Phone (305) 894-3238 Fla. WATS 1-800-432-9424 Outside Florida 1-800-327-1917	<b>CLEARWATER, Fla.</b> 33575 1898 Drew Street Phone (813) 461-4267 No In-State WATS No Nationwide WATS	<b>LAS VEGAS, Nev.</b> 89106 1072 N. Rancho Drive Phone (702) 647-3114 No In-State WATS Outside Nevada 1-800-634-6227	<b>CHICAGO, Illinois</b> 60630 ERICKSON COMMUNICATIONS 5456 N. Milwaukee Avenue Phone (312) 631-5181 Outside Illinois 1-800-621-5802
--	---	---	---	--



AEAEAEAEAEAEAEAEAEAEAEAE  
 AEAEAEAEAEAEAEAEAEAEAEAE  
 AEAEAEAEAEAEAEAEAEAEAEAE  
 AEAEAE

# DOCTOR QSO<sup>TM</sup>

Relieves All Symptoms Of  
 Morse Code Phobia!



\$79.95 AM NET

## A Realistic Simulation of On-the-Air, Two-Way Morse Code 'Ragchew' Contacts (QSOs).

- Makes Upgrading of Morse Skills Easy and Fun
- Does Away With Drudgery
- Skilled Operators Enjoy the Realism
- Operate Anytime—Requires Only a Commodore C-64 (or C-128) and A TV Set
- Removes the "Mystery" of what to Say in On-the-Air Contacts
- Excellent Practice for Beginners and Old "Pro's"
- Standard Format and Common Abbreviations Used for All Exchanges
- Send Morse with your keyboard
- Select Appropriate QRM and QRN Levels
- Select the Portion of the 'Band'—Novice or Low End

Prices and Specifications Subject to Change Without Notice or Obligation

ADVANCED ELECTRONICS APPLICATIONS, INC.  
 P.O. Box C-2160, Lynnwood, WA 98036

TELEX: 6972496  
 AEA INTL UW  
 (206) 775-7373

**AEA** BRINGS YOU THE  
 BREAKTHROUGH





Falcon Communications, Well Known for MOSFET Repeater Power Amplifiers, Also Makes A Hard Working Line Of Bipolar Power Amplifiers For Mobile Use. Our 2 Meter Amplifiers Include:

Model 5121	2 Watts in = 150 out 1 Watt in = 90 out	List \$285
Model 5122	10 Watts in = 150 out 2 Watts in = 50 out	List \$275
Model 5123	30 Watts in = 150 out 10 Watts in = 90 out	List \$235
Model 6126	10 Watts in = 75 out 2 Watts in = 30 out	List \$170
Model 4109	plug in receive pre-amp 12 db gain 2 db noise figure	List \$36

**A FEW FEATURES:**

1) Made in the USA	4) Automatic COR or remote keying
2) All mode (FM, SSB, CW)	5) Built in thermal protection
3) Optional plug-in receive preamp	6) Full 1 Year warranty

*For Information On Our Complete Line See Your Local Dealer Or Call Factory Direct*

**P.O. Box 8979 • Newport Beach, CA 92658**  
**(714) 760-3622**



**STILL LOOKING FOR QUALITY  
 WIRE & CABLE  
 AT THE RIGHT PRICE?**

RG-213 MIL SPEC 97% SHIELD	28 50/ft
RG-214 MIL SPEC DBL SILVER SHIELD	\$1 50/ft
RG-174 MIL SPEC 97% SHIELD	100c/ft
RG-8X (MINI 8) FOAM 95% SHIELD	12 50c/ft
RG-8U FOAM 95% SHIELD	24 50c/ft
RG-58A/U MIL SPEC 97% SHIELD	12c/ft
RG-11A/U MIL SPEC 97% SHIELD	28c/ft
RG-59U MIL SPEC 97% SHIELD	12c/ft
300 OHM KW TWIN LEAD	16c/ft
450 OHM HD LADDER LINE POLY INS	100c/ft
450 OHM HD LADDER LINE BARE 100 ft ROLL	\$13 00
4 CONDUCTOR ROTOR CABLE	80c/ft
6 CONDUCTOR ROTOR CABLE	140c/ft
8 CONDUCTOR ROTOR CABLE (2#18/6#22)	16 50c/ft
8 CONDUCTOR ROTOR CABLE HD (2#16/6#18)	34c/ft
14 GA STRANDED COPPERWELD 70 ft ROLL	\$6 50
14 GA STRANDED COPPERWELD 140 ft ROLL	\$12 00
14 GA HD STRANDED COPPER	9c/ft
12 GA HD SOLID COPPERWELD	10c/ft
14 GA HD SOLID COPPERWELD	8c/ft
18 GA HD SOLID COPPERWELD	4c/ft

\*SOLD IN CONTINUOUS LENGTHS TO 5000 FT. IN 50 FT. MULTIPLES ONLY.

**LA CUE, INC.**  
 132 Village Street  
 Johnstown, PA 15902  
 orders only  
**1-800-637-3300**

PUBLISHED BY:  
 THE AMERICAN RADIO  
 RELAY LEAGUE



THE ARRL  
 1986 HANDBOOK  
 FOR THE RADIO AMATEUR



STATE OF  
 THE ART

*The ARRL 1986 Handbook For The Radio Amateur carries on the tradition of the previous editions by presenting 1192 pages of comprehensive information for the radio amateur, engineer, technician and student. Paper edition: \$18 in the U.S., \$19 in Canada, and elsewhere. Clothbound \$27 in the U.S., \$29 in Canada and elsewhere.*

THE AMERICAN RADIO RELAY LEAGUE  
 225 MAIN ST.  
 NEWINGTON, CT 06111

# Don't buy from Hamtronics . . .

Unless you want the best possible equipment at the lowest possible price! !

The "wheeler-dealer" is back and he's beating everyone else's "deals."

We all know there's no such thing as a free lunch . . . so How Can We Do This?

- **We don't** run alot of ads featuring sale items
- **We don't** spend alot of money on full page ads
- **We don't** have sales on just the fastest selling products
- **We don't** short cut you on service. We are a factory warranty repair facility for everything we sell!
- **We don't** mail out free catalogs
- **We don't** have a free WATS number.

You and every other Ham customer is paying for all these do-dads and sales gimicks.

**Hamtronics** puts the savings into your pocket.

**Hamtronics** guarantees to meet or beat any advertised price on every item we sell.

## Hamtronics Has It All!

Let **Hamtronics** be your Ham Radio equipment dealer. We're celebrating our 35th year in the Ham business at the same location.

ICOM DAY JANUARY 25, 1986

# HAMTRONICS, INC.

A DIVISION OF TREVOSE ELECTRONICS  
4033 BROWNSVILLE RD., TREVOSE, PA 19047  
(215) 357-1400







**OC-1 ONLY \$59.95**

Complete with Shipping/Handling USA



**OC-2 ONLY \$79.95**

**ON CALL** is a complete selective call system so you don't have to monitor the frequency, or it can be used as a decoder for controlling equipment at the repeater site and at home.

Compare these features:

- 4 digit 16 tone sequential decoder programmable, 43,680 different codes, DTMF Format with Auto reset
- 1 AMP SPST relay output, momentary or latched for external paging device, such as Auto horn, tape recorder, speaker Audio etc.
- Flashing LED call indicator. (Energizes when your code has been accessed).
- easy connection to any radio
- 12-16 volt DC operation
- Size: OC-1 - 3.1 x 2.15 x .5 in.  
OC-2 - 2.3 x 3.75 x .875 in.
- can be used for clubs or emergency groups for help situations

To Order Send Check or Money Order To: **URGENT DEVELOPMENT CORPORATION**

MC/VISA  
NYS Residents Add Sales Tax

E. Carter Rd.  
PO Box 384  
Westmoreland, NY 13490  
or Phone 315-733-3719

## REPEATER VOTER

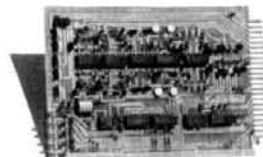

### 4RV Four Channel Repeater Voter

- Signal to Noise Type
  - Expandable to 32 Channel by Just Adding Cards
  - Designed for Commercial and Amateur Service
  - Continuous Instant Voting
  - Dual or Single 12 Volt Supply
  - LED Indicators of COR and Voted Signals
  - Front Mounted Level Pots
  - Built in Calibrator
  - Remote Voted Indicators Pinned Out
  - 4 1/2" x 6" Double Sided Gold Plated 44 Pin Card
  - Unswitched Audio Input
  - On Board Audio Switching and Mixing
  - Audio Mixer Input Available for External Input
  - Open Collector or Relay Contact Input
  - Open Collector NPN Output
  - Remote Disable Inputs
  - More
- 4RV Kit including board and parts with 20 page manual . . . \$200.00**  
**Built, tested, and calibrated with manual . . . \$350.00**
- For more information call or write: **(614) 261-8871**  
**VOTER Hall Electronics**  
815 E. Hudson Street  
Columbus, Ohio 43211

## SPECIAL SALE — SAVE \$5 EACH

**Have a name — but need the Call Sign?  
Traveling — and want to meet local Hams?**

1985-1986 Amateur Radio

### NAME INDEX

By Name and Call 583 pages

1985-1986 Amateur Radio

### GEOGRAPHICAL INDEX

By State, City, Street No. and Call 653 pages

No frills directories of over 462,000 U.S. Radio Amateurs. 8 1/2 x 11, easy to read format.

NAME INDEX — ~~\$25.00~~ \$19.95

GEOGRAPHICAL INDEX — ~~\$26.00~~ \$19.95

**BUY BOTH SPECIAL \$35.95**

Add \$1.50 shipping to all orders.

**ham radio** magazine

**BOOKSTORE**

Greenville, NH 03048

## THE COMMODORE COMBINATION!

THE COMMODORE HAM'S COMPANION

COMMAND POST

As featured on Radio Sweden, Radio Netherlands and the WSTI Report.

The Commodore Ham's Companion: A 160 page paperback guide to using your Commodore computer in the ham shack. Good solid information on where to find software and hardware to use for CW, RTTY, AMTOR, SSTV, packet propagation, prediction, antenna modeling, satellite tracking and much more. Includes a list of over 80 sources of Commodore amateur radio software and hardware and a bibliography of over 60 magazine articles and reviews about using Commodore machines in the ham shack.

Command Post: A 32 page reprint of the popular Command Post column that includes Basic language program listings you can type in for CW and RTTY send and receive, dupe checking, program exchange and more. It also serves as a tutorial on the basics of interfacing Commodore machines for control operations.

Commodore Ham's Companion \$15.95

Command Post \$9.95

**SPECIAL \$19.95** for both books when ordered together

**\$2.50 First Class shipping and handling applies on all US orders**

Mastercard and Visa accepted. 121

**QST**  
PUBLISHING

P.O. Box 3042  
Springfield, IL 62708

# quartz crystal resonators

## Learn how to specify crystals using frequency/temperature relationships

**This article provides** tools for specifying, testing, and controlling the parameters of piezo-electric crystals. This data is designed to allow you to specify your requirements exactly to the crystal supplier. Also included are TI-55-II calculator programs showing examples that reduce the burden of calculations.

The article is based on practical experience with thousands of crystals used in the communications industry. Because of the competitive nature of the business and the large quantities involved, crystals must be both low in cost and usable, in that they must be capable of being placed on the specified frequency and remain on frequency (within the limits specified) despite changes in both time and temperature.

### the crystal impedance meter

When crystals are ordered from catalogs, problems frequently arise. Invariably the crystals quoted are to a military specification. There is nothing wrong with this as long as the circuit in which the crystal has to work matches it and provides the exact conditions specified. In practice this is generally not the case, and as a result, crystals that arrive may be within the specifications when tested in the standard Crystal Impedance (CI) meter, but may not meet your requirements when used in the actual oscillator circuit.

A quick look at some typical crystals listed in a vendor's catalog can give us some clues. We find among the specifications a variety of capacitances quoted. The values shown are frequently relics from the days of vacuum tubes and are used in the CI meter, selectable by a switch. This is all very convenient; the CI meter, however, looks at the crystal and measures it

as an impedance — hence its name, “crystal impedance” meter. It is therefore not operating under the conditions that an oscillator places on it. You will also note that some crystals are series resonant. In this case, there is no loading capacitor, because the crystal is being driven and is operating into a purely resistive load. These crystals are thus on frequency only if used under those conditions.

As we go above 20 MHz, we get into the realm of overtone crystals. These crystals are, however, not an exact third or fifth or higher multiple of the fundamental. If the use of multipliers is to be avoided, these crystals can serve a very useful purpose, but there are advantages and disadvantages that must be considered.

### example using 10-MHz crystal

We will now look at a typical requirement and consider a crystal that operates at 10 MHz in the parallel or antiresonant mode. (The series configuration is referred to as the resonant mode.) The crystal will therefore operate with a loading capacitance of 20 pF and in the fundamental mode. The crystal cut will typically be AT-cut, operating temperature 78.8 degrees F (26 degrees C) and frequency tolerance  $\pm 20$  ppm (other specifications we will consider later.) After obtaining samples from three different vendors and measuring them in the CI meter, we found each crystal to be at 10.000150 MHz, thus 15 ppm high. All crystals meet specifications, appear to be identical. However, all are not identical because the compliance,  $C_S$  has values of 0.01, 0.02, and 0.04 pF, respectively. ( $C_S$ ,  $L$ , and  $R$  are inherent in the crystal.) **Figure 1** shows the electrical equivalent; this is the crystal without any electrodes attached. Inductance  $L$  is the electrical equivalent of the crystal mass. Capacitor  $C_S$  is the compliance and  $R$  is due to the losses by mechanical friction of the crystal. This electrical circuit is series resonant. **Figure 2** shows the crystal with its deposited electrical contacts. This is achieved by placing a small spot of a conducting material, such as silver, on each

By Peter Boddaert, 11 Blossom Road, Braintree, Massachusetts 02184



table 1.

			crystal 1			
$C_S$ (pF)	$C_L$ (pF)	$C_S/2C_L$ (pF)	$F_S$ (MHz)	$F_P$ (MHz)	$\Delta F$ (Hz)	L (mH)
0.01	31	0.0001613	9.998243	9.999855	- 145	
0.01	26	0.0001923	9.998243	10.000166	+ 166	25.339
0.01	21	0.0002381	9.998243	10.000624	+ 624	
total pulling = 769 Hz = $\pm 38.5$ ppm						
			crystal 2			
0.02	31	0.0003226	9.996310	9.999535	- 466	
0.02	26	0.0003845	9.996310	10.000154	154	12.674
0.02	21	0.000476	9.996310	10.001068	1068	
total pulling = 1533 Hz = $\pm 76.665$ ppm						
			crystal 3			
0.04	31	0.0006452	9.992487	9.998934	- 1068	
0.04	26	0.0007692	9.992487	10.000174	+ 176	6.342
0.04	21	0.0009524	9.992487	10.002004	+ 2,004	
total pulling figure = 2,004 + 1066 = 3070 Hz = $\pm 153.5$ ppm						

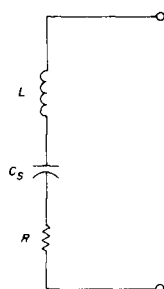

fig. 1. Crystal blank showing relationship of parameters inherent in the crystal: compliance,  $C_S$ ; electrical equivalent of the crystal mass,  $L$ ; and losses caused by mechanical friction of the crystal,  $R$ .

side and making electrical connections to these. As a result a capacitor is now formed, which together with the holder  $C$ , appears in parallel with the series resonant circuit, producing a parallel or antiresonant circuit. This capacitance is shown as  $C_P$  with a typical value of 6 pF.  $C_L$  is the load capacitance of 20 pF. The crystal thus sees the sum of  $C_P$  and  $C_L = 26$  pF as a total load capacitance. In a practical circuit  $C_L$  is usually made variable so that the oscillator can be adjusted to frequency. A trimmer capacitor typically provides a minimum variation from 15 to 25 pF. Thus the actual load capacitance can vary between 21 and 31 pF.

We will now calculate the pulling figure or pulling ability of each crystal using the above values of loading  $C$  for each of the three crystals. We will also calculate the series resonant frequency,  $F_S$ , and the value for  $L$ . (See table 1.)

A convenient formula for parallel-resonant frequency is

$$F_P = F_S [1 + (C_S/2C_L)] \quad (1)$$

We see that the pulling ability or the ability to place the oscillator on frequency, is greatly influenced by  $C_S$ . Failure to control its value can result in being unable to place units on frequency without making modifications or, if the  $C_S$  is large such as in crystal 3, the pulling ability can become excessive. Such crystals are prone to frequency jump more so than those that have a smaller value of  $C_S$ . It must be remembered that *all* crystals have spurious responses not too far removed from the desired frequency. Such spurs can show up under certain conditions such as when a change in temperature occurs. A simple rule of thumb is: a crystal has a maximum pulling ability of 100 ppm.

We find that crystal 2 meets our requirement of being able to set it to frequency with a sufficient amount of overlap at each end. Crystal 1 would also be suitable; however, at the low end, things are tight. Allowing for component variations in production, together with the fact that the crystal frequency could be higher by another 50 Hz and still be within specifications, it would be desirable to be able to reject those at the incoming inspection. A simple solution to this problem is to specify pulling ability rather than the loading capacitance. The crystal specification would include:

- The frequency.
- Pulling ability in the test circuit (minimum =  $\pm 35$  ppm, maximum =  $\pm 85$  ppm).
- Approximate loading capacitance (*for reference only*), 20 pF.

There is, therefore, no reference to frequency tolerance because this is now taken care of by the pulling ability. In addition, the value of the loading capacitance is now used as a general guideline rather than an absolute value.

Of course, the vendor must now be supplied with a test circuit. This will consist of the complete oscillator plus all of its associated circuitry; an isolating stage, mixer, and such. It must be identical with the production units. Keep in mind that any test equipment such as a frequency counter connected to the circuit will have some influence on it, so the coupling must be as loose as possible to minimize these effects. Also be aware that any tuned circuits may have some effect on the frequency. Before shipping the test circuit to your supplier, check for the correlation between it and the in-house standard. There are bound to be some variations between them, and allowance must be made for this.

### the overtone crystal

As mentioned, the overtone crystal operates on an odd harmonic of its resonant frequency such as third, fifth, seventh and higher. These crystals are more frequently employed in the series-resonant mode (although they can, of course, also operate in the parallel mode).  $C_S$  is extremely small. For example, in a fifth overtone crystal,  $C_S$  is on the order of 0.0005 pF at 70 MHz. Hence these crystals are much more difficult to pull on frequency by using a capacitor and consequently, are relatively unaffected by changes in the rest of the circuit because of temperature variations. With these crystals, however, a test circuit should be used and supplied to the vendor.

### drive level

In general, crystal levels should be kept low. Some manufacturers specify a maximum level for AT-cut crystals operating in the fundamental mode, as 5 milliwatts. But whatever the maximum level quoted, it is better and safer to stay well below that value for a number of reasons:

- Excessive drive levels can break the crystal.
- The frequency stability is poor because of crystal heating, which causes excessive drifting.
- The crystal is much more susceptible to jump frequency or to operate on one of the crystal spurs, or to deliver an output at two or more frequencies simultaneously. These effects are most likely to show up with temperature variations.
- Note that the drive level will have some effect on the frequency; generally, doubling drive level will cause 2 ppm change.

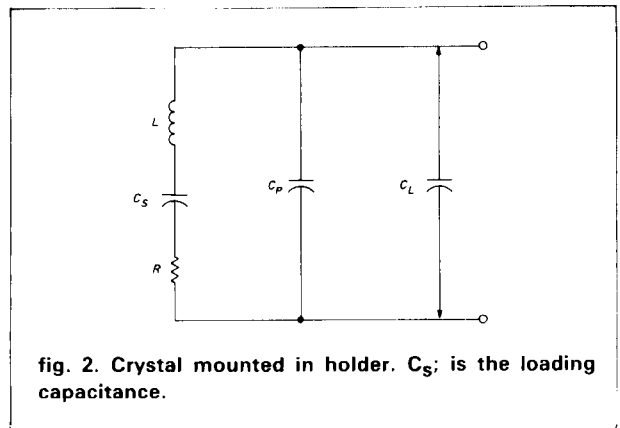

### frequency-temperature characteristics

The AT-cut crystal has been cut at an angle of 35 degrees. **Figure 3** shows the frequency/temperature/angle-of-cut characteristics. Note that the turnover points are placed almost symmetrically on either side of the center point, 79 degrees F (26 degrees C). For example, with the cut at +20 minutes, the upper turnover point (UTP) is at 223 degrees F (106 C) and the lower turnover point (LTP) is at -47 degrees F (-44 C). Thus at 144 degrees F (80 C) and -126 degrees F (-70 C), they are on either side of the center point.

At times, then, one would specify these points — for example, if the crystal were to be placed in an oven that operates at, say 176 degrees F (80 degrees C). It would then be a good policy to have the crystal *on frequency at the turnover point* of 176 degrees F (80 C), for at that point the rate of change is least, thus improving frequency stability. Bear in mind, however, that components that are not temperature controlled, but form a part of the frequency-determining network, will still have an influence on frequency stability; thus, if at all possible, they too should be inside the oven.

Another frequently called specification states that the frequency must be within  $\pm 10$  ppm over the temperature range of 158 degrees F (70 C) to -22 degrees F (-30 C). Inspection of **fig. 3** shows that the cut at +4 minutes can meet this, but only barely. There is no margin for error in the angle of cut or for external component changes or tolerances. As a consequence, in the test area, the rejection rate is likely to be high. Generally, oscillators of this nature incorporate some form of temperature correction circuit consisting of thermistors or varactor diodes.

Unfortunately, these circuits invariably have to be adjusted during test, thus causing an added expense.

### using NTC capacitors

**Figure 4** shows a typical oscillator. Assuming the capacitances due to the transistor are small and can be ignored, we have a 20 pF loading capacitance made

table 2. Results.

temperature	-2.0 F (-19 C)	25 F (-4 C)	52 F (11 C)	79 F (26 C)	106 F (41 C)	133 F (56 C)	160 F (71 C)
F <sub>P</sub> (MHz)	9.999804	9.999879	9.999954	10.000031	10.000109	10.000189	10.000270
ΔF (ppm)	-19.550	-12.137	-4.589	3.045	10.914	18.866	26.951
C <sub>L</sub> (pF)	21.755	21.059	20.385	19.732	19.101	18.490	17.899

table 3. Corrected figures.

temperature	-2.0 F (-19 C)	25 F (-4 C)	52 F (11 C)	79 F (26 C)	106 F (41 C)	133 F (56 C)	160 F (71 C)
ΔF (ppm)	-22.595	-15.182	-7.634	0	7.869	15.821	23.906

up by the trimmer in series with the two 150-pF capacitors. Most mobile radio equipment is required to operate over the temperature range of -22 degrees F (-30 degrees C) to 158 degrees F (70 C). Thus with a total temperature change of 180 degrees F (100 C) the N2200 capacitors will change by: TC × change in degrees F × 5/10,000 × 9 equals percent. (TC × change in degrees C/10,000 = percent), where TC is the temperature coefficient. Thus 2200 × 100/10,000 = 22 percent, so that the total value of the two 150-pF capacitors in series = 75 ± 11 percent. At -22 degrees F (-30 C) the capacitance is 83.25 pF; at 158 degrees F (70 C) it is 66.75 pF.

The trimmer, which has a value of 27 pF, will change by 7.5 percent over the temperature range, thus at -22 degrees F (-30 C) it will be 28.01 pF and at 158 degrees F (70 C) it will be 25.99 pF. The total C that the crystal thus works into at 158 F (70 C) is the series combination of 66.75 + 25.99 pF in parallel with a C<sub>P</sub> of 6 pF, or a total of 18.71 + 6 = 24.71 pF. At -22 degrees F (-30 C) this becomes 20.96 + 6 pF = 26.96 pF.

If we use these capacitors in conjunction with crystal 2, which has a C<sub>S</sub> of 0.02 pF and F<sub>S</sub> = 9.99631 MHz, we thus obtain F<sub>P</sub> at 158 F (70 C) = F<sub>S</sub> × 1.0004048 = 10.000357 MHz, and at -22 F (-30 C) = F<sub>S</sub> × 1.0003709 = 10.000018 MHz. The total frequency change thus brought about = 339 Hz, a variation of 33.9 ppm. With the help of fig. 3, we can now locate a crystal that has its turnover points at ± 17 ppm. The chart shows an 8 minutes cut to be close, with turnover points at -11.2 degrees F and 168.8 degrees F (-24 C and 76 C, respectively) and a frequency variation of + and -20 ppm. The frequency changes due to the crystal would thus be reduced to approximately ± 3 ppm by the use of NTC capacitors, a very worthwhile improvement obtained without any increase in cost or number of components. Of course, the example given here is not the only combination. Had we

chosen crystal 3, with a C<sub>S</sub> of 0.04 pF, we would have obtained twice as much pulling ability, and thus use capacitors with a smaller NTC. Using a 12 minute angle places the turnover points further out thus extending the usable temperature range of the oscillator. Do not, however, lose sight of the fact that any circuit variations brought about by temperature changes will have an effect on the frequency so that bypass capacitors, layout and component placement, and good engineering principles must be taken into account.

### long-term stability

Some manufacturers publish figures for their crystals. In general the cold weld type holder will have better long-term stability. It is not easy to determine as it is a matter of time; however, to achieve the greatest stability the oscillator should operate continuously. It should also be subjected to a program of temperature cycles with the oscillator operating before setting it to frequency. How much aging can one expect? It is not unreasonable to look for a ± 3 ppm/year figure, which in most applications is very acceptable.

### resistance and temperature

The series resistance of the AT-cut crystal tends to go down in value as the frequency increases when operating in the fundamental mode. With overtone-mode crystals the reverse occurs. In the range of 5 to 20 MHz, a maximum value of 50 ohms is reasonable. Overtone crystals tend to have series R values about 50 percent higher. The resistance tends to be temperature sensitive and can easily double in value at 158 F (70 C). In some cases this could lead to oscillator failure or to a considerable reduction in output power. Specifying the maximum R over the operating temperature range rather than at 79 F (26 C) can avoid any misunderstandings with the manufacturer over this matter. Keep in mind, however, that over-specifying costs money. The tighter the specifications, the

**ICOM****KENWOOD YAESU**

IC-735 New, compact HF Transceiver ..... **Regular SALE**  
 IC-751 9-band Xcvr/1.30 MHz Rcvr ..... **Call**  
 IC-745 9-band Xcvr/1.30 MHz Rcvr ..... **\$1399.00 Call**  
 IC-745 9-band Xcvr/1.30 MHz Rcvr ..... **\$ 999.00 Call**



IC-271 hi 100w 2m FM/SSB/CW Xcvr ... **\$899 Call**  
 IC-271A 25w 2m FM/SSB/CW Xcvr. **\$699.00 Call**  
 IC-471A 10w430-450 SSB/CW/FM Xcvr **\$799.00 Call**



IC-02AT **Call**  
 IC-04AT **Call**  
 IC-2AT **Call**  
 IC-3AT **Call**  
 IC-4AT **Call**

**IC-R71A  
GENERAL  
COVER RCVR**

TS-940S/AT ..... **Regular SALE**  
 TS-930S/AT ..... **\$1995.00 Call**  
 TS-930A ..... **\$1799.00 Call**  
 TS-930A ..... **\$1599.00 Call**



TS-711A TS-811A ..... **Call**



TR-2600A **Call**  
 TH-21A **Call**  
 TH-21AT **Call**  
 TH-41A **Call**  
 TH-41AT **Call**

**R-2000  
GENERAL  
COVER**

FT-980 ..... **Regular SALE**  
 FT-0NG ..... **\$1659.00 Call**  
 FT-0NG ..... **Call**



FT-726R ..... **\$ 899.00 Call**



FT-209RH **Call**  
 FT-709RH **Call**  
 FT-203RH **Call**  
 FT-103R **Call**  
 FT-703R **Call**

**FRG-8800  
GENERAL  
COVER RCVR****SALE!!  
NEW RTTY/CW  
COMPUTER  
INTERFACES****BIRD****THIS MONTH'S  
SPECIALS**

ICOM R71A  
 LIST \$799.95 — **SALE \$599.95**  
 Call for Kenwood R-2000  
 YAESU FT-2700 RH  
 with FTS8  
**SALE \$499.95**  
**LIMITED QUANTITIES!**

**MIRAGE  
AMPLIFIER****SALE!****AMERITRON  
AL-80**

**JUN'S**  
**ELECTRONICS**  
 800-882-1343  
 INCLUDES ALASKA  
 HAWAII  
 Calif. Call  
 Collect  
 for Order

- AMATEUR ● TWO WAY ● MARINE
- CELLULAR MOBILE PHONE ● SCANNER
- ★ Free U.P.S. Cash Order (Most Item, Most Place)
- ★ Shoppers, call us last, save \$\$
- ★ SE HABLA ESPANOL

**(213)390-8003** 3919 Sepulveda Blvd.  
 Culver City, CA 90230

## HF ANTENNAS — The Easy Way

by John Haerle, WB5IIR

This book has been published as a memorial to WB5IIR's work as an Amateur Radio teacher.

Originally given as a series of speeches or papers, this tutorial is an excellent source book on antenna theory and applications. Examples of areas covered are: *Fundamentals*, antenna and feedline

terminology, baluns, ground systems, lightning protection, *The Basic Antenna*, the dipole, the zepp, G5RV, Windom, *Special Antennas*, the sloper, DDDR, Beverage, folded unipole, *Beams*, WBJK, Yagi, two element quad, and the *160 meter band story*. John's writing is in an easy-to-understand conversational style and is full of examples and handy tips and hints. There are no drawings or illustrations but John's prose paints pictures for clear and complete understanding of the information being presented. ©1984 1st Edition.

JH-AT

**Softbound \$11.95**

Please add \$3.50 for shipping and handling.

**ham  
radio** magazine  
 GREENVILLE, NH 03048

**BOOKSTORE**  
 (603) 878-1441

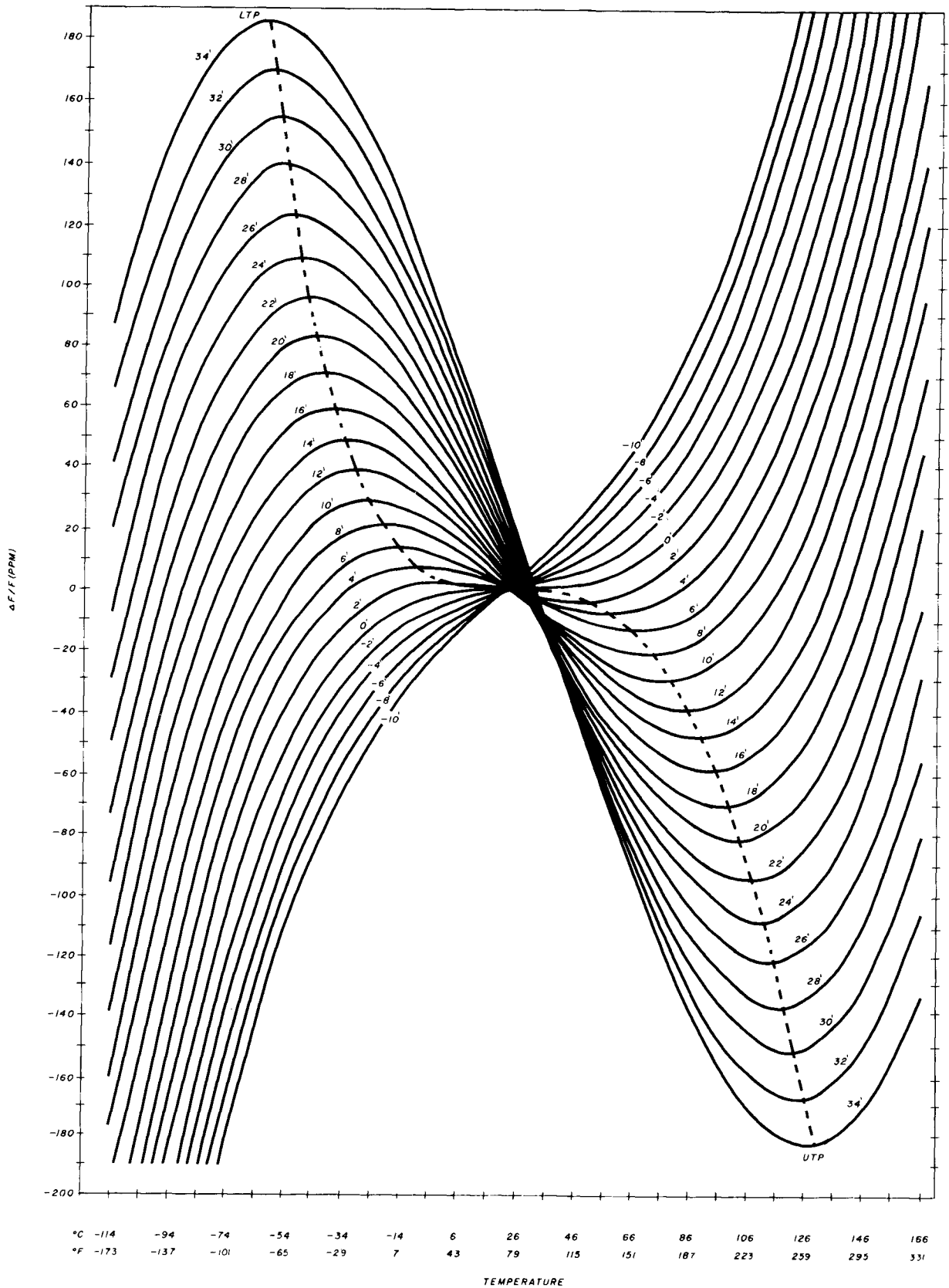
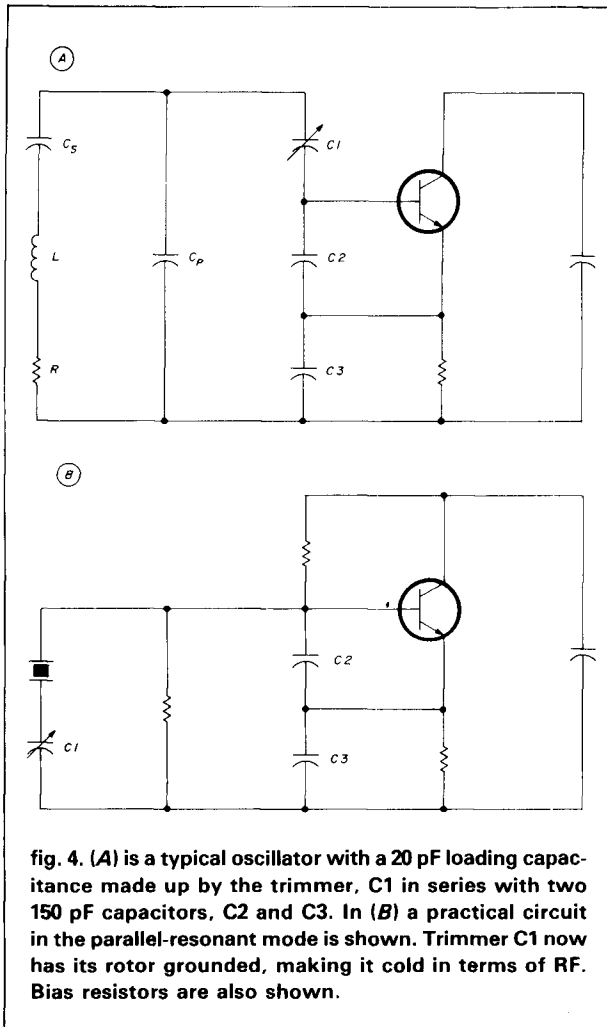

fig. 3. Frequency/temperature angle of cut characteristics for quartz crystal resonators. LTP and UTP are respectively lower and upper turnover points. Chart is for AT-cut crystals.





more expensive the product. Very low series R is also possible, which in some cases can lead to oscillator squegging. Placing a lower limit on the R value can avoid this problem.

### spurious responses

As mentioned earlier, all crystals have a number of resonances at unwanted frequencies and in some instances located close to the desired frequency. In some situations this can present a problem, with the oscillator suddenly jumping to one of these. A consultation with the vendor on this matter and a thorough testing of the initial design for this potential trouble is most desirable. If necessary the spurious response characteristics of the crystal should be included in the specifications. Experience shows that these precautions can save a lot of headaches later on.

### vendor selection

The vendor is most important; good rapport is essential. Make it clear at the onset that you will not accept units that fail to meet the specifications and

that he owns *all* rejects no matter how large the quantity. Also let him know that you intend to conduct inspection tests for compliance to specifications. For small quantities, every unit will be tested; for large quantities testing will be conducted on a sampling basis. The sampling method plus the amount of rejects found in the sample size before rejection should be explained and agreed upon by all concerned, because this will be part of the purchase contract.

Crystal manufacturers tend to specialize; consequently, the vendor who makes excellent low-frequency crystals may not produce the best high-frequency crystals. This can be especially true for overtone crystals so make sure that you select a vendor who demonstrates both the ability and willingness to produce crystals that consistently meet all your requirements. It is a mistake to press a supplier to make something that he is not really comfortable or experienced with; sooner or later, things will go wrong, spoiling a good relationship.

Today, computers and software that will determine the pulling ability of the crystals and print out a histogram of the results as well are easily available. A copy of this information sent to the supplier will enable him to make any slight modifications to his next production run if necessary.

### determining $F_p$ , $\Delta F$ , $C_L$

We have looked at quartz crystals in general and at some of the desirable parameters. I also proposed the use of NTC capacitors to compensate the frequency deviation of the crystal with temperature. I then showed that pulling ability is important, much more so than is generally realized. By placing a minimum/maximum limit on it, we get the Series C, a property of the crystal under manufacturing control, ensuring consistency of the product as well as the ability to place the crystal on frequency in our circuit and to apply temperature compensation.

In the previous example the minimum/maximum pulling ability was specified as  $\pm 35$  ppm and  $\pm 85$  ppm. Statistically the mean is thus  $\pm 60$  ppm. Inspection of the formula for  $F_p$  and the example crystals 1, 2, and 3 shows that the pulling ability of the crystal is directly proportional to the value of  $C_S$ .

Taking crystal 1 as an example with  $C_S$  at 0.01 pF and pulling ability at  $\pm 38.5$  ppm, then  $C_S$  for the average crystal with  $\pm 60$  ppm pulling ability =  $(60/38.5) \times 0.01 = 0.016$  pF. We can now also calculate  $F_S$  for this crystal using the formula for  $F_p$  and transposing:  $F_S = F_p/[1 + C_S/2 C_L]$ , which, with  $F_p = 10$  MHz and  $C_L = 26$  pF = 9.996923 MHz. As this is the crystal we will be working with, and for easy reference, we place the parameters on one line:  $F_S = 9.996923$  MHz,  $C_S = 0.016$  pF,  $F_p = 10.000,000$  MHz,  $C_L + C_p = 26$  pF.

**table 4. Results.**

temperature	-2.0 F (-19 C)	25 F (-4 C)	52 F (11 C)	79 F (26 C)	106 F (41 C)	133 F (56 C)	160 F (71 C)
crystal $\delta'$ (ppm)	21	18	10	0	-10	-17	-21
corrected (ppm)	-22.595	-15.182	-7.634	0	7.869	15.821	23.906
error (ppm)	-1.595	2.818	2.366	0	-2.131	-1.179	2.906

**table 5. Results.**

temperature	2.0 F (-19 C)	25 F (-4 C)	52 F (11 C)	79 F (26 C)	106 F (41 C)	133 F (56 C)	160 F (71 C)
$F_p$ (MHz)	9.999905	9.999945	9.999985	10.000026	10.000067	10.000108	10.000150
$\Delta F$ (ppm)	-9.474	-5.485	-1.460	2.604	6.704	10.842	15.017
$C_L$ (pF)	20.817	20.463	20.115	19.773	19.437	19.107	18.782

**table 6. Corrected figures.**

temperature	-2.0 F (-19 C)	25 F (-4 C)	52 F (11 C)	79 F (26 C)	106 F (41 C)	133 F (56 C)	160 F (71 C)
$\Delta F$ (ppm)	-12.078	-8.089	-4.064	0	4.1	8.238	12.413

Next, determine and tabulate the values of  $C_L$ ,  $F_p$ , and the change of  $F_p$  (from that at 79 degrees F (26 C) in frequency and ppm with temperature. Except for the frequency, it serves no practical purpose to tabulate beyond three decimal points; similarly, there is little to be gained in making the temperature steps closer than 27 degrees. An operating range of 81 degrees F (45 C) above and below 79 degrees (26 C) is sufficient for most applications.

### capacitors with N2200 temperature coefficients

In the following example,  $C_1$ ,  $C_2$ , and  $C_3$  have an N2200 temperature coefficient. And since they are all in series (fig. 4A) it is a simple matter to calculate  $C_L$  at 79 degrees F (26 C).  $C_L = 1/(1/27 + 1/75) = 1/(0.0370 + 0.0133) = 19.853$  pF. Next, calculate the new value of  $C_L$  at a temperature 27 degrees F (15 C) below 79 degrees F (26 C). We can use either the formula above or use the calculator program shown in appendix A. As this calculation is very simple (there being no mixture of TCs) we will use the formula, thus:  $2200 \times 15/10,000 = 3.3$  percent. The new capacitive value is  $= 19.853 \times 1.033 = 20.508$  pF. That is, for every 27 F (15 C) degree decrease in temperature, the capacitance increases by 3.3 percent. Conversely, the capacitance decreases in value by 3.3 percent for every 27 F (15 C) degree increase in temperature. Hence the multiplier is then  $1/1.033 = 0.968$ . It is this value that is used in the calculator program in appendix B as the capacitance multiplier.

To use the program we enter in lines 02, 03, 04 the capacitance multiplier 968 plus the other values as shown (which belong to the crystal.) We then start

calculations by entering into the calculator display the value of  $C_L$  at 15 degrees C below the lowest temperature of interest, thus in the example at  $-60$  C ( $\Delta T$ ),  $(-29$  F or  $-34$  C)  $= 1.132 \times 19.853 = 22.47$  pF. Note that the value of  $C_L$  at 79 degrees F (26 C) (19.853 pF) is not used in the program.

We now have the calculated values of  $F_p$  in MHz at every 15-degree C interval as well as the change in  $F_p$  ( $\Delta F$ ) in ppm (table 2). We find at the 26-degree C point an error of 3.045 ppm. In practice, correction is by adjusting  $C_1$  to pull it on frequency. On paper, we do it by subtracting 3.045 ppm from each figure (see table 3).

Our next step is to look at the curves of figs. 3 and 5. These are the frequency/temperature curves for AT-cut crystals. Note the dashed line which intersects the upper and lower turnover points with the various angles of cut. For our purpose, fig. 5 is more convenient to use. Now project on this set of curves, at the  $-2.2$  F ( $-19$  C) point, the  $-22.595$  ppm obtained from the corrected figures in table 3, but with a change of sign. Thus as a + quantity, it intersects the LTP just above the 8 minute cut and in the other direction, at 160 F (72 C), it is close to intersecting the UTP of a 9 minute cut.

A crystal with an LTP at  $-2.2$  F ( $-19$  C) of 22 ppm would appear to be our best bet, (approximately an 8 minute cut). Tabulating the figures for this crystal and subtracting the corrected figures from them, we obtain the results shown in table 4.

We have thus improved the frequency/temperature performance of the system from a maximum variation of 42 ppm to one with a change of 5.037 ppm, about an 8:1 improvement.

**DO YOU  
KNOW  
WHERE  
TO FIND  
REAL  
BARGAINS**



**on NEW and USED  
ELECTRONIC Equipment?**

**You'll Find Them  
in the Nation's No. 1  
Electronic Shopper Magazine**

# NUTS & VOLTS

**Now in Our 5th Year**

Nuts & Volts is published MONTHLY and features:  
**NEW STATE-OF-THE-ART PRODUCTS •  
SURPLUS EQUIPMENT • USED BARGAINS  
• LOW COST AD RATES • PRIVATE AND  
COMMERCIAL CLASSIFIEDS • NATIONAL  
CIRCULATION • NEW PRODUCT NEWS  
SECTION • AND A FREE CLASSIFIED AD  
WITH YOUR SUBSCRIPTION**

### SUBSCRIPTION RATES

- One Year - 3rd Class Mail ..... \$10.00
- One Year - 1st Class Mail ..... \$15.00
- One Year - Canada & Mexico (in U.S. Funds) .. \$18.00
- Lifetime - 3rd Class Mail (U.S. Only) ..... \$35.00

### ORDER NOW!

SEND:     CHECK     MONEY ORDER  
           VISA         MASTERCARD

TO:        **NUTS & VOLTS MAGAZINE  
             P.O. BOX 1111-H  
             PLACENTIA, CALIFORNIA 92670  
             (714) 632-7721**

Name \_\_\_\_\_  
Address \_\_\_\_\_  
City \_\_\_\_\_  
State \_\_\_\_\_ Zip \_\_\_\_\_  
Card No. \_\_\_\_\_  
Exp. Date \_\_\_\_\_

**IF YOU'RE INTO ELECTRONICS,  
THIS MAGAZINE WILL SAVE YOU MONEY!**

Dealer Inquiries Invited

✓ 128

# ORLANDO HAMCATION AND COMPUTER SHOW MARCH 7, 8, 9, 1986 500 W. Livingston FLORIDA STATE ARRL CONVENTION



## REGISTRATION

**\$5.00 ADVANCE • \$7.00 AT DOOR  
SUN., MARCH 9, FCC EXAMS**

**FREE PARKING AVAILABLE ALSO  
FOR R.V. AND CHARTER BUSES**

**FOR SWAP TABLES,  
COMMERCIAL BOOTHS  
ADVANCE REGISTRATION**

**OR**

## INFORMATION

**PLEASE SEND  
SELF ADDRESSED STAMPED ENVELOPE  
TO:**

**HAMCATION CHAIRMAN  
P.O. BOX 15142  
ORLANDO, FL 32858  
(305) 422-ARRL**

**ALL IN AIR-CONDITIONED COMFORT**

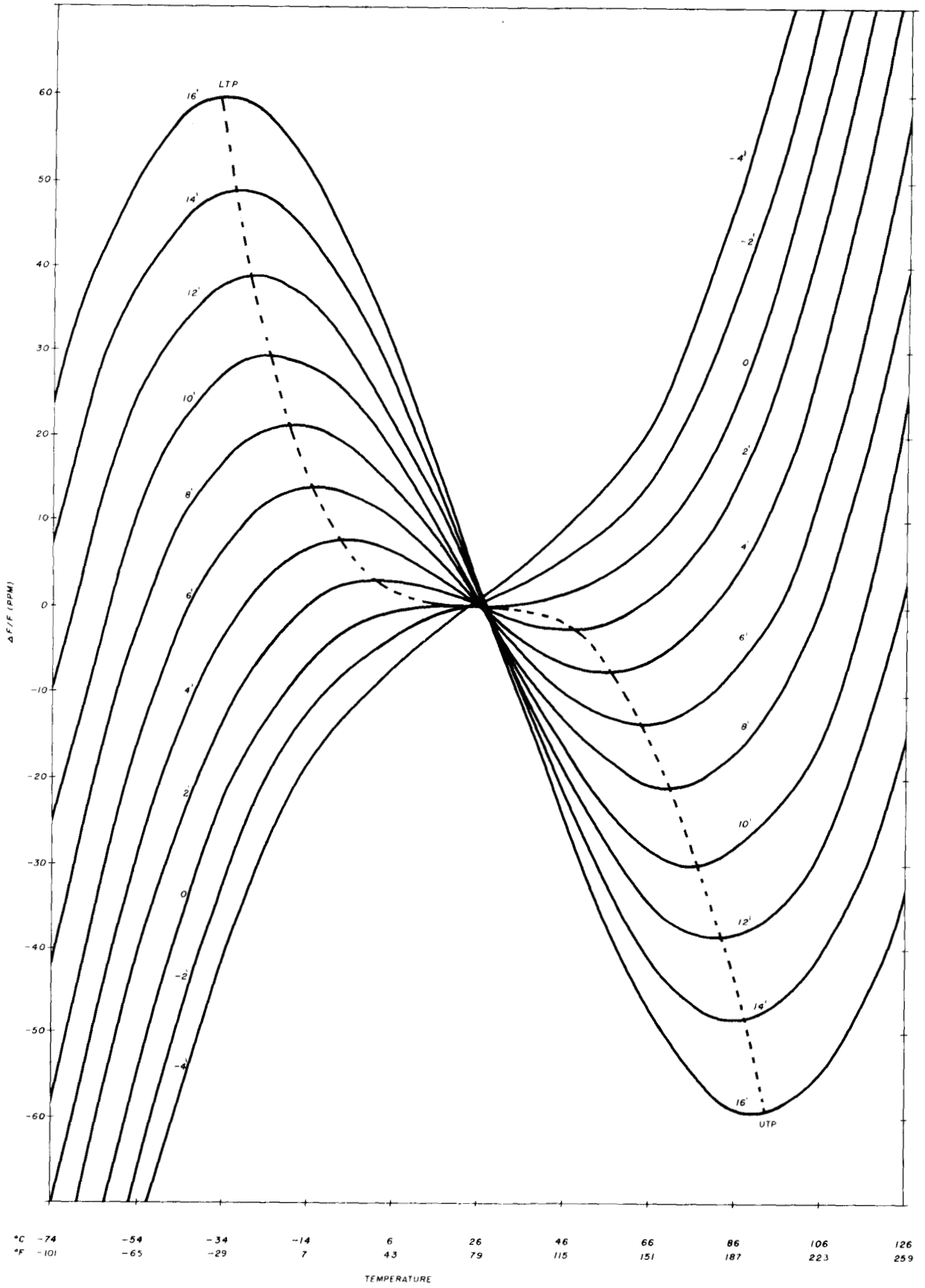

fig. 5. Frequency/temperature curves used to demonstrate crystal performance. (A text example. Chart is for AT-cut crystals.)

table 7. Results.

	- 2.0 F (- 19 C)	25 F (- 4 C)	52 F (11 C)	79 F (26 C)	106 F (41 C)	133 F (56 C)	160 F (71 C)
crystal 5.5' (ppm)	12	11	7	0	- 6.5	- 11	- 12
corrected (ppm)	- 12.078	- 8.089	- 4.064	0	4.1	8.238	12.413
error (ppm)	- 0.078	2.911	+ 2.938	0	- 2.400	- 2.762	0.413

## N750 temperature coefficient material

In the next example, the TC of C1 is changed to an N750 material. Because we are now employing two different TC materials in the capacitors forming C<sub>L</sub> it is easier to make use of the program in **appendix A**. Calculate the value of C<sub>L</sub> at 15 C and at - 60 C | - 29 F (- 34 C) below 79 F (26 C). The rest of the calculations are the same as for our first example. The value of C<sub>L</sub> at 79 F (26 C) is of course, still 19.853 pF. Capacitors C2 and C3, being identical and in series, are thus treated as one capacitor of 75 pF.

temperature	52° F (11°C)	- 29° F (- 34°C)
C1 (pF)	= 27.304	28.215
C2,3 (pF)	= 77.475	84.900
C <sub>L</sub> (pF)	= 20.189	21.177

The capacitance multiplier =  $20.189/19.853 = 1.017$  and the value used in the calculator program is  $1/1.017 = 0.983$ . Start the calculations by entering into the display C<sub>L</sub> at - 29 F (- 34 C) = 21.177 pF.

We have now the calculated values of F<sub>P</sub> (in MHz) (see **table 5**) at every 15 C-degree interval, also the change in F<sub>P</sub> (ΔF) in ppm. We now correct for the shift at 79 F (26 C), by subtracting 2.604 from each reading see (**table 6**).

Turning now to the curves (**fig. 5**) locate at - 2.2 F (- 19 C) the + 12.078 ppm point. This is located just below the + 6 minutes cut, which has its LTP at 7 F (- 14 C) and at the 13.5 ppm point. Thus a crystal, having an angle of cut just a fraction below this would probably be our best bet, a cut having its LTP at: 14 F (- 10 C) degrees with + 12 ppm (approximately a 5.5 minutes cut). Tabulating the figures for this crystal and subtracting the "corrected figures" from them, we obtain the results shown in **table 7**. We have thus improved the frequency/temperature performance from a 24 ppm change to 5.848 ppm, an improvement of 4:1.

## summary

The improvement in frequency drift with temperature is considerable and obviously desirable. Instead of specifying the angle of cut, specify either the LTP or the UTP (whichever is more important), giving both the temperature and the amount of change desired from the 79 F (26 C) degree point. Since these points

are easily measured using standard test equipment, the manufacturer decides on the angle of cut. Crystals tend to show hysteresis, or inability to retrace reverse conditions, so temperature/frequency measurement should always be made from the same direction in terms of temperature.

To obtain the greatest frequency stability with temperature and time variations, and if power conservation is of secondary importance, place the complete oscillator in a temperature controlled oven, specify the crystal frequency and the UTP at the oven temperature, and allow both to operate continuously.

Where power preservation is important, such as in portable equipment, use NTC capacitors to compensate the crystal and specify the upper and lower turn-over points. Place the capacitors close to the crystal so that they also "feel" the same temperature, keeping them clear from heat generating parts.

Overtone crystals are frequently used in the resonant mode. It is generally desirable to tune out C<sub>p</sub> with an inductance to prevent oscillations at a frequency determined by this capacitance. Frequency adjustment by the addition of a small amount of inductance is possible.

## appendix A

### TI-55-II programming

Calculates capacitance with change of temperature. Requires three data memories that contain the numerical values of C, the temperature change or the temperature coefficient, and the number 1,000,000. Displays the new capacitance value.

step	key	line no.	key code	remarks
1	x	00	65	
2	RCL	01	71	
3	1	02	01	memory 1, stores TC or temperature change
4	÷	03	55	
5	RCL	04	71	
6	2	05	02	memory 2, stores 1,000,000
7	=	06	95	
8	x	07	65	
9	RCL	08	71	
10	0	09	00	
11	=	10	95	memory 0, stores the value of C
12	..	11	75	
13	RCL	12	71	
14	0	13	00	
15	=	14	95	memory 0, stores the value of C
16	±	15	94	
17	RST	16	22	displays the new value of C and resets the calculator to start
18	LRN			takes the calculator out of the learning mode.



Now, key in the value of  $C(27)$  and STO in 0. Place  $TC(750)$  in STO 1 and 1,000,000 in STO 2. Clear display and press RST. Key into the display the temperature  $-50$  C. press R/S. The display should show 28.0125, thus the capacitance increased with a reduction of  $-50$  C in temperature.

Next place into the display 50, then R/S, and the display will show 25.9875, thus a decrease in capacitance with increasing temperature. Thus, by placing the TC of the capacitor into memory 1, and with the capacitor's value stored in memory 0, we can conveniently find the new value with any change of temperature. Interchanging TC with temperature, thus placing the temperature change in memory 1 and keying the TC into the display, will show the effect of changing TC on the capacitance value with various temperature coefficients.

## appendix B

### TI-55-II programming

Calculates and displays each new value of  $F_p$ ,  $\Delta F$  from  $F_p$  at 26 C degree, and the new value of  $C_L$  (in pF). Note that F is shown in + or - ppm. Requires three data memories. Memory 0 stores the new (decremented) value of  $C_L$ , memory 1 contains  $F_S$  in MHz (to six decimal places), and memory 2 contains the value of  $F_p$  at 26 degrees C also to six decimal places.

step	key	line no.	key code	remarks	example
1	x	00	65		
2	.	01	93		
3	*	02	*		9
4	*	03	*	enter: capacitive multiplier	6
5	*	04	*		8
6	=	05	95		
7	STO	06	61	memory 0 must be empty (0) at the start	
8	0	07	00		
9	+	08	85		
10	*	09	*	value of $C_p$ (6 pF)	6
11	=	10	95		
12	x	11	65		
13	2	12	02		
14	=	13	95		
15	÷	14	55		
16	*	15	93		
17	*	16	*	value of $C_S$ (0.016 pF)	0
18	*	17	*		1
19	*	18	*		6
20	x-y	19	52		
21	+	20	85		
22	1	21	01		
23	=	22	95		
24	x	23	65		
25	RCL	24	71	enter $F_S$ in memory 1	9.996923
26	1	25	01		
27	=	26	95		
28	R/S	27	12		
29	-	28	75		
30	RCL	29	71	enter $F_p$ at 26 degrees C in memory 2	10.000000
31	2	30	02		
32	-	31	95		
33	+	32	55		
34	RCL	33	71		
35	2	34	02		
36	=	35	95		
37	2nd Eng	36	47		
38	R/S	37	12		
39	RCL	38	71		
40	0	39	00		

End of program. Automatically resets and displays the new value of  $C_L$ , which is now in memory 0.

To start, press RST, enter  $F_S$  in memory 1 and  $F_p$  in memory 2. Check that memory 0 is 0. Enter into the display the value of  $C_L$  at  $-76$  F ( $-60$  C). Example 22.474. Press R/S. Displays  $F_p$  at  $-2$  F ( $-19$  C) = 9.999804. Press R/S, display  $-19.550706$ . This is the change in frequency from  $F_p$  at 26 C =  $-19.550$  ppm. Press R/S, display = 21.754832 00; thus 21.755 pF, which is  $C_L$  at  $-2$  F ( $-19$  C). Press R/S again. This repeats the calculations, using this time  $C_L$  at  $-2$  F ( $-19$  C), calculates all the 25 F ( $-4$  C) parameters, and so on, saving a lot of repeating calculations.

## appendix C

### TI-55-II programming

To calculate  $F_p = F_S [1 + (C_S/2C_L)]$  requires four data memories that will contain the numerical values of  $C_S$ ,  $C_L$ ,  $F_S$ , and  $F_p$  at 26 C degrees in this order. In the same order will be displayed the values of  $C_S/2C_L$ ,  $F_p$  and the difference between  $F_p$  and the  $F_p$  at 79 F (26 C), thus  $\Delta F$ . Partition four memories and place the calculator in the learn mode.

step	key	line no.	key code	remarks
1	RCL	00	71	
2	0	01	00	memory 0 stores $C_S$
3	÷	02	55	
4	(	03	53	
5	2	04	02	
6	x	05	65	
7	RCL	06	71	
8	1	07	01	memory 1 stores $C_L$
9	)	08	54	
10	-	09	95	
11	R/S	10	12	displays value of $C_S/2C_L$
12	+	11	85	
13	1	12	01	
14	-	13	95	
15	x	14	65	
16	RCL	15	71	
17	2	16	02	memory 2 stores the value of $F_S$ in MHz
18	-	17	95	
19	R/S	18	12	displays the value of $F_p$ in MHz
20	-	19	75	
21	RCL	20	71	
22	3	21	03	memory 3 stores $F_p$ at 26 C degree point, (thus with a total $C_L$ at 26 pF). Example 10.000000 MHz)
23	-	22	95	
24	RST	23	22	displays the difference between $F_p$ and the value contained in memory 3 takes calculator out of learning mode.
25	LRN			

Key in the value of  $C_S$  (0.01) and STO in 0. Place  $C_L$  (26) in STO 1,  $F_S$  in STO 2, and in STO 3. Place 10,000,000. Now press ON/C to clear the display. Check the contents of each memory for errors. If OK again clear the display and press R/S to run the program. The first stop should be  $C_S/2C_L = 0.0001923$ . Press R/S again, up comes  $F_p = 10.000166$  and finally the frequency difference at 0.0001667 MHz. Press 2nd, Fix 6, which will fix the display to 6 decimal points.

ham radio

# W6SAI BOOKS

published by Bill Orr, W6SAI and Stu Cowan, W2LX

### BEAM ANTENNA HANDBOOK

Completely revised and updated with the latest computer generated information on BEAM Antenna design. Covers HF and VHF Yagis and 10, 18 and 24 MHz WARC bands. Everything you need to know. 204 illustrations. 268 pages. ©1985. Revised 1st edition.

IRP-BA

Softbound \$9.95

### SIMPLE LOW-COST WIRE ANTENNAS

Primer on how-to-build simple low cost wire antennas. Includes invisible designs for apartment dwellers. Full of diagrams and schematics. 192 pages. ©1972 2nd edition

IRP-WA

Softbound \$7.95

### ALL ABOUT CUBICAL QUAD ANTENNAS

Simple to build, lightweight, and high performance make the Quad at DX'ers delight. Everything from the single element to a multi-element monster. A wealth of information on construction, feeding, tuning and installing the quad antenna. 112 pages. ©1982. 3rd edition.

IRP-CQ

Softbound \$6.95

### THE RADIO AMATEUR ANTENNA HANDBOOK

A wealth of projects that covers verticals, long wires, beams as well as plenty of other interesting designs. It includes an honest judgement of gain figures, how to site your antenna for the best performance, a look at the Yagi-Quad controversy, baluns, slopers, and delta loops. Practical antenna projects that work! 190 pages. ©1978. 1st edition.

IRP-AH

Softbound \$7.95

Please enclose \$3.50 for shipping and handling.



ham  
radio magazine BOOKSTORE  
GREENVILLE, NH 03048 (603) 878-1441

# HOT ROD ANTENNA

Achieve 1 or 2 db gain over ANY 1/4 wave two meter telescopic antenna. The AEA model HR-1 Hot Rod™ antenna was designed by Dr. D.K. Reynolds (designer of the IsoPole) to deliver maximum performance for any hand-held transceiver with a BNC fitting.

The factory-tuned HR-1 is 20% shorter, lighter and places far less stress on your hand-held connector and case. It will easily handle over 25 watts of power, making it an excellent emergency base or mobile antenna. In the collapsed position, the Hot Rod antenna will perform like a helical quarter wave.

The Hot Rod antennas can be expected to make the same improvement to hand-held communications that the IsoPole brand antennas have made to base station operations. Why pay more when the best costs less?

Prices and Specifications subject to change without notice or obligation.

## ADVANCED ELECTRONIC APPLICATIONS, INC.

P.O. Box C-2160,  
Lynnwood, WA 98036  
(206) 775-7373  
Telex: 152571 AEA INTL

# AEA Brings you the Breakthrough!

186

**OUT NOW!**

**FREE**

**THE DICK SMITH ELECTRONIC ENTHUSIASTS CATALOG**

132 PAGES CRAMMED WITH KITS, BOOKS, COMPONENTS, DATA-HAM GEAR AND MORE PLUS BONUS COUPONS WORTH \$2 REDEEMABLE OFF YOUR 1st ORDER

Rush me my copy of the Dick Smith Catalog, I enclose \$1 to cover shipping

Name .....

Address .....

City .....

Zip .....

DICK SMITH ELECTRONICS INC.  
P.O. Box 2249 Redwood City CA 94063



# ENGINEERING CONSULTING

583 CANDLEWOOD ST.  
BREA, CALIFORNIA 92621

**COM-SHACK 64  
SIMPLEX AUTO-PATCH  
& REMOTE H.F. BASE**

MODEL CS-64

**\$229<sup>95</sup>**

Includes Software (Program Disk), Hardware Interface & Instruction Manual

**NEW!**

TELEPHONE 714-671-2009

CQ DX, CQ DX 20 Meters

This is NI6R Auto-patch On!

This is NI6R Remote Base Auto-patch On

- Simplex autopatch and H.F. remote base with clear voice messages
- Control your Yaesu FT 757 transceiver with your VHF/UHF portable or mobile
- Switch between the H.F. remote and the autopatch with DTMF tones
- Voice ID & all control functions & H.F. frequency are voice announced with your programmable access codes
- Autopatch works on any telephone line — tone or dial pulse
- Call waiting compatibility — after beep answer second incoming call while on the patch!
- Automatic redial last number (in dial pulse mode)
- Ring detect & automatic voice alert of incoming telephone call
- Inactivity timer turns off system (user programmable)
- Store 8 H.F. memory frequencies + shift VFO's & change bands
- Fast scan & slow scan + dial up any frequency with DTMF tones all from your handheld VHF/UHF portable or mobile
- Use the autopatch or the remote base both for the price of one!
- User defined timing window, access codes, call sign
- Simple to install hardware interface cables, connectors supplied
- Hook mic input, PTT, spkr outputs & FM squelch connection 3 pin H.F. data cable and you are in control
- You supply — 1 Commodore 64 or 128 & 1 disk drive + base station
- No additional power supply required
- With human voice synthesized by Covox™

Send Check of M.O. to  
**ENGINEERING CONSULTING**  
583 CANDLEWOOD STREET  
BREA, CA 92621

## TOUCHTONE™ DECODER KIT

MODEL TTK

**\$22<sup>95</sup>**

- SSI201 DTMF Receiver
- Receive all 16 DTMF digits
- No additional filtering
- Output BCD or hex format
- Low power (29 ma @ 12V)
- Kit includes 3.58 Mhz crystal, 22 pin IC socket, resistor, capacitors, data sheet and schematics

## 4-DIGIT SEQUENCE DECODER

WIRED & TESTED MODEL TSD

**\$59<sup>95</sup>**

- Completely wired & tested
- User programmable • LED status indicator
- Open collector output
- Control relays; mute audio
- Control link on/off
- Custom IC insures high reliability & small size!
- Fits inside most rigs: runs on 12 VDC (35 ma)
- All 16 digits allow more than 50,000 combinations
- Makes excellent private call on busy repeaters!
- Use it to turn on audio or sound an alarm
- Momentary and latching outputs

Mastercard and Visa accepted  
Prices include postage & handling, U.S.A.  
California addresses add 6%

## "DECODE-A-PAD"

MODEL DAP-1

**\$89<sup>95</sup>**

- Use your computer to decode DTMF touchtones
- Receive all 16 digits as fast as they can be transmitted
- Easily program your computer in BASIC to decode multidigit "strings", display digits, sound alarms, observe secret codes, control relays
- Simple to use; just provide +12 VDC and audio, hook two wires to the RS-232-C serial input on your computer, enter a simple BASIC program and begin to decode
- Sample BASIC program and instructions included
- Data indicator
- Wired and tested

## TUNE THE WORLD FROM YOUR HANDHELD VHF/UHF RADIO

2 FOUR DIGIT DTMF DECODERS, PLUS 16 DIGIT KEYPAD CONTROL

Model RAP-1  
**REMOTE-A-PAD™ \$149<sup>95</sup>**

- Audio tones from any source, are converted to solid state switches which control any 16 digit keypad of a radio or other device
- Some examples you can control include the Pro-Search™ Rotator (rotate beam remotely); Remote controls: ICOM IC-701 or ICOM IC-211 when using the RM-2 controller; Kenwood 7950 & 751; Azden PCS 4000; handhelds such as Yaesu FT-208; FT-708; ICOM IC-D2AT; and many more.
- Two (four-digit) programmable access codes are used to operate relays or other on/off functions
- LED decoder status indicators and momentary plus steady state decoder outputs are provided
- All CMOS low power drain (30ma); S.S.1 201 Decoder
- Hook eight wires (4 rows and 4 columns) in parallel with the existing keypad of the radio you wish to control remotely
- Connect audio from any source, 12 volts D.C. and you are in control
- The dual 4 digit decoders will turn your links on and off using your programmable access code.

Send Check of M.O. to  
**ENGINEERING CONSULTING**  
583 CANDLEWOOD STREET  
BREA, CA 92621

## ICOM IC-D2AT USER'S "AUDIO BLASTER" MODULE

1000's of Satisfied Customers

**\$19<sup>95</sup>**



- Module installs inside the radio in 10 minutes
- Boost audio to nearly one watt!
- Low power drain (4ma stand-by)
- Complete step-by-step instructions included
- Corrects the LOW audio problem!
- Drive external speakers to full volume, even signals with low deviation!

## AMATEUR RADIO MAIL LISTS

Sell-stick 1x3 labels

\*\*\* NEWLY LICENCED HAMS \*\*\*  
\*\*\* ALL NEW UPGRADES \*\*\*  
\*\*\* UPDATED EACH WEEK \*\*\*

Total List = 462,728 (ZIP sorted)  
Price is 2.5 cents each (4-up Cheshire)

BUCKMASTER PUBLISHING  
Mineral, Virginia 23117  
703:894-5777

172

## MULTI-BAND SLOPERS

ALSO DIPOLES & LIMITED-SPACE ANTENNAS

Outstanding performance of WINN antennas is well known. Now enjoy low SWR • Coax feed • 3kw power • Compact • FULLY ASSEMBLED to your specified center frequency each band • Easy to INSTALL • Very low profile • Complete instructions • Your personal check accepted

4 BAND SLOPER 160, 80, 40, 30, or 20M	60 ft long	\$ 48 ppd
3 " " " " " " " " " " " "	60 ft "	\$ 43 "
2 " " " " " " " " " " " "	40 ft "	\$ 35 "
1 " " " " " " " " " " " "	113 ft long	\$ 71 "
2 " " " " " " " " " " " "	80 40M	\$ 55 "
4 BAND SPACE SAVER DIPOLE 160 thru 10M*	\$ 81 long	\$ 85 ppd
* Requires wide-range tuner (80, 40, 20, 15M without tuner)		

SEND SASE for complete details of these and other unique antennas

WINN ANTENNAS 312-394-3414  
BOX 393-H MT. PROSPECT, IL 60056

103

# NEMAL ELECTRONICS INTL., INC.

NOW AUTHORIZED BELDEN DISTRIBUTOR

your one stop coax supplier!



**Exclusive**

## SATELLITE CONTROL CABLE

5 TYPES AVAILABLE!

NEW!!! Lowest Loss

AVAILABLE IN  
250-500-1000  
FT. ROLLS  
OR BY  
THE FOOT

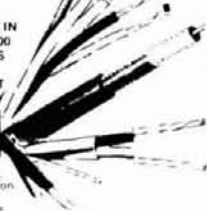

Designed for easy, one-step installation providing the required cables for most earth station equipment all in a direct burial jacket

TYPE 1 (General Purpose)	TYPE 2 (M/I)	TYPE 3 (Internal)	TYPE 4	TYPE 5
1- RG59/U 96% Copper Braid	1- RG59/U 96% Copper Braid	2- RG59/U 96% Copper Braid	1- RG6/U 18 Gauge 96% Copper Shield	2- RG6/U 18 Gauge 96% Copper Shield
2- 18 Gauge	2- 12 Gauge	2- 12 Gauge	2- 17 Gauge	2- 12 Gauge
3- 22 Gauge	3- 18 Gauge	3- 18 Gauge	3- 18 Gauge	3- 18 Gauge
4- 20 Gauge	4- 20 Gauge	4- 20 Gauge	4- 20 Gauge	4- 20 Gauge
Shielded plus Tinned Copper Drain Wire	Shielded plus Tinned Copper Drain Wire	Shielded plus Tinned Copper Drain Wire	Shielded plus Tinned Copper Drain Wire	Shielded plus Tinned Copper Drain Wire
55¢ FT	75¢ FT	95¢ FT	79¢ FT	89¢ FT

Only Nemal offers the quality construction RG59/U copper shielding made to mil spec JAN C 17 12 gauge conductors, tinned copper drain wires, and a true direct burial polyethylene jacket

### HARDLINE

Two styles, two sizes for all installation needs

- Aluminum Outer Conductor with Polyethylene Jacket**
  - 1/2 inch loss 48 dB/100 ft @ 30 MHz
  - 3.68 dB/100 ft @ 1000 MHz \$1.25/ft
  - 7/8 inch loss 28 dB/100 ft @ 30 MHz
  - 2.54 dB/100 ft @ 1000 MHz \$3.25/ft

- Corrugated Copper Outer Conductor with Polyethylene Jacket**
  - 1/2 inch loss 38 dB/100 ft @ 30 MHz
  - (FLC12-50J) 2.78 dB/100 ft @ 1000 MHz \$1.59/ft
  - 7/8 inch loss 13 dB/100 ft @ 30 MHz
  - (FLC12-78J) 1.3 dB/100 ft @ 1000 MHz \$3.92/ft

COMPARE RG 213 1.25 dB/100 @ 30 MHz  
8.5 dB/100 @ 1000 MHz

### HARDLINE CONNECTORS

- 1/2 inch aluminum UHF M/F \$19.00 Type N M/F \$22.00
- 7/8 inch aluminum UHF M/F \$49.00 Type N M/F \$49.00
- 1/2 inch copper UHF M/F \$22.00 Type N M/F \$22.00
- 7/8 inch copper UHF M/F \$49.00 Type N M/F \$49.00

### shipping

Cable — \$6.00 per 100 ft.  
Connectors — \$3.00 per order.  
Orders under \$20 add \$2 additional plus shipping.  
Charge card — orders over \$30 only.  
COD add \$2.00. Florida Residents add 5%.

FACTORY AUTHORIZED DISTRIBUTOR  
AMPHENOL, CABLEWAVE, COLUMBIA, KINGS  
BLONDER-TONGUE, TYTON, B&K

- COAXIAL CABLE
- MULTICONDUCTOR CABLE
- CONNECTORS-ADAPTERS
- HARDLINE
- CABLE TIES
- SMATV PRODUCTS
- COAX-SEAL
- COMPUTER CABLE
- CRIMP TOOLS
- FIELD STRENGTH METER

### COAXIAL CABLE SALE POLYETHYLENE DIELECTRIC

RG-8/U 96% shield Mil Spec	(\$29.00/100) or	31¢/ft
RG11U 96% shield 75 ohm mil spec		25¢/ft
RG-55B/U double shield (RG-58 size) 50 ohm		45¢/ft
RG58U mil spec 96% shield (\$10.00/100) or		11¢/ft
RG62A/U 96% shield mil spec 93 ohm		12¢/ft
RG174/U min. 50 Ω mil spec		10¢/ft
RG213 noncontaminating 96% shield mil spec		36¢/ft
RG214/U double shield silver shield 50 ohm		\$1.65/ft
RG214/U tinned copper		65¢/ft
RG217/U double shield 50Ω 5/8" OD		85¢/ft

### LOW LOSS FOAM DIELECTRIC

RG-8X (Mini 8) 95% shield	(\$15.00/100) or	17¢/ft
RG8U 80% shield	(\$19.00/100) or	22¢/ft
RG-8/U 97% shield 11 ga. (eq. Belden B214)		31¢/ft
RG58U 80% shield		07¢/ft
RG58U 95% shield		10¢/ft
RG59/U 100% foam shield TV type		10¢/ft
RG59/U 70% copper shield		09¢/ft
HEAVY DUTY ROTOR CABLE 2-16 ga 6-20 ga		36¢/ft
Rotor cable 2-18 ga 6-22 ga Poly burial Jkt.		19¢/ft

### CONNECTORS MADE IN USA

Amphenol PL 259		89¢
PL 259 and/or SD-239	65¢ ea or	10/\$5.99
Double Male Connector		\$1.79
PL 258 Double Female Connector		98¢
PL 259 Silver-Teflon Kings		\$1.59 ea
Reducer UG 175 or 176	22¢ or	10/\$2.00
UG-255 (PL 259 to BNC)		\$2.95
Elbow (M359) UHF Elbow		\$1.79
F59A (TV type)	24¢ or	10/\$2.00
UG 21 D/U Type N Male for RG8, Amphenol		\$3.00
UG-88C/U BNC Male for RG-58, Amphenol		\$1.25
UG 273 BNC-PL259 Amphenol		\$3.00
3/16 inch Mike Plug for Collins etc. (cutoff)		\$1.25

### shipping

Cable — \$3.00 per 100 ft.  
Connectors — add 10%, \$3.00 minimum.  
Orders under \$20 add \$2 additional plus shipping.  
Charge card — orders over \$30 only.  
COD add \$2.00. Florida Residents add 5%.

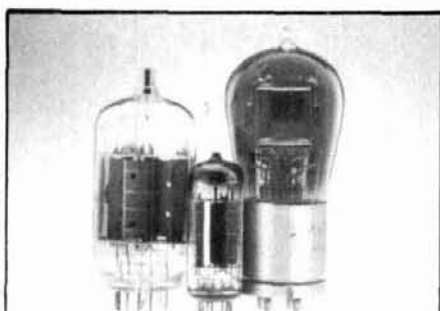

## TUBES—2,000 TYPES DISCOUNT PRICES!

New 20-pg. wholesale catalog for the radio collector/hobbyist. Antique, hard-to-find and modern tubes. Also transformers, capacitors and parts for tube equipment, and books, etc.

### Antique Electronic Supply

688-F W. First Street  
Tempe, AZ. 85281  
602/894-9503

✓ 176

## 40m Phased Array —the Easy Way!

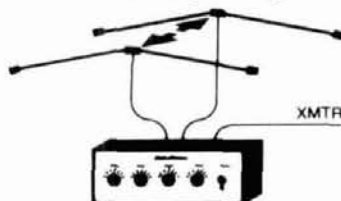

### OPTI-PHASOR™ by BaileyTech

- Change direction instantly
- High F/B, adjustable phasing
- Low SWR over entire 40m band
- Just 2 dipoles gives 4 db gain

\$119.95 Also available with matched dipoles and feed lines.

Check, MO, VISA, M/C  
Call or Write for Complete Catalog.  
TET Antennas, Larsen, Hy-Gain,  
Alpha Delta, etc.

## SULTRONICS

1587 U.S. 68 N Xenia, OH 45385  
(513) 376-2700

✓ 111

## AUTHORIZED KENWOOD I-COM RADIO DEALER



✓ 151

H. L. HEASTER, INC., 203 Buckhannon Pike, Clarksburg, W. Va. 26301 Clarksburg Phone (304) 624-5485 or W. Va. Toll-Free 1-800-352-3177

HAROLD HEASTER, K80HX, 91 Ridgefield Place, Ormond Beach, Fl. 32074 Florida Phone (904) 673-4066

NEW NATION-WIDE TOLL-FREE TELEPHONE 1-800-84-RADIO  
1-800-84-72346

Call us for a quotation, WE WILL SAVE YOU MONEY!

## GUS BROWNING, W4BPD's DX'ERS MAGAZINE

For over 17 years, Gus's DX'ERS MAGAZINE has brought thousands of DX'ERS worldwide, timely, pertinent information on when and where to find those elusive DX stations.

Gus's personable, chatty writing style and his years of DX operating experience makes the DX'ERS MAGAZINE a unique publication. One year \$14.00 USA, Canada & Mexico.

Gus also prints high quality QSLs and other related items.

Write today for a free sample of his QSLs and DX'ERS MAGAZINE.

Gus Browning, W4BPD • PO Drawer 405 • Cordova, SC 29039



✓ 156

# NEW products

## MFJ-815 cross-needle SWR/wattmeter

MFJ's new cross-needle SWR/wattmeter, the MFJ-815, enables hams to read SWR, forward, and reflected power at a single glance. No SWR setting is needed at any range.

The average forward and reflected power can be read in three ranges: 20/200/2000 watts forward and 5/50/500 watts reflected. SWR can be read from 1:1 to 5:1 on a two-color scale. This unit works from 1.8 to 30 MHz, and accuracy



is  $\pm 10$  percent full scale. The MFJ-815 also features easy push-button range selectors.

The MFJ-815 sells for a retail price of \$59.95 each, and can be found at many of the MFJ dealerships nationwide. All MFJ products are backed by a one-year unconditional warranty and an additional 30-day guarantee covering products purchased directly from the company.

For further information, contact MFJ Enterprises, Inc., P.O. Box 494, Mississippi State, Mississippi 39762.

Circle #302 on Reader Service Card.

## questions about satellite TV? free booklet has the answers

Seventy-eight of the most frequently asked questions about satellite TV are answered in a new 16-page, 6 by 9-inch booklet available free from Luxor.

Arranged in an easy-to-follow question & answer format, *Everything You Need To Know About Home Satellite TV* is divided into seven sections: "Getting Started," "The Channels," "The 'Birds,'" "Satellite TV Programming," "The Dish," "Satellite TV Receivers," and "Tuning In." Diagrams such as shown in **fig. 1** illustrate the basic operation of a home satellite TV system, the location of the Clarke satellite belt, and a typical satellite "footprint."

## HOW DOES A SATELLITE TV SYSTEM WORK?

TV signals (picture and sound) are transmitted by a studio to one or more satellites. These satellites orbit the earth at a distance of 22,300 miles above the equator. The orbit of communications satellites is geosynchronous, that is, their locations remain fixed in relation to the earth. The satellites re-transmit the signals to earth where they reach a dish. The dish reflects or focuses them to a low-noise amplifier (LNA). From the amplifier, signals go to a downconverter, which lowers the frequency. Signals are then brought into the home by coaxial cable to a satellite TV receiver. This receiver processes the signals, permits selection of one of 24 channels transmitted by the satellite, and sends the signal to a TV set where the picture is viewed.

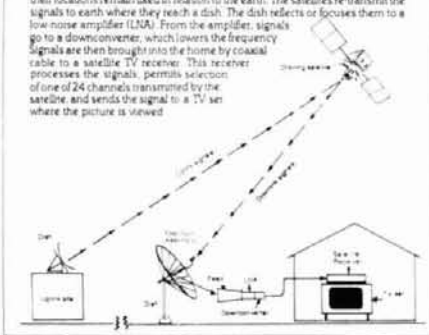

Dish with a clear line of sight to the domestic satellites.

**fig. 1. Luxor's free 16-page booklet answers commonly-asked questions about home satellite TV, using text and illustrations such as this.**

Free copies are available from Luxor North America Corporation, 600 108th Avenue N.E., Bellevue, Washington 98004.

Circle #304 on Reader Service Card.

## tough tool kits

A selection of best-selling field engineer's tool kits from Jensen Tools, Inc. is now available in rugged military style cases. Designed to endure rough handling and harsh industrial or military environments, these cases are molded of high-density polyethylene and are 20 to 25 per cent thicker than conventional cases, and can withstand temperature extremes ranging from 200 F to +185 F.



Unique features include a permanent olive drab (FFD-STD-595) finish; heavy-duty tongue and groove aluminum valance with gasket to seal out dirt and moisture; combination lock and padlock loops for added security; spring-loaded handles, low profile, quarter-turn latches; and molded-in stacking lugs to provide strength and secure stacking during storage.

These cases are offered with the Jensen JTK-17, JTK-87 or JTK-99 tool and pallet selections, or they can be bought separately without tools.

For more information or a free catalog, contact Jensen Tools Inc., 7815 South 46th Street, Phoenix, Arizona 85044.

Circle #305 on Reader Service Card.

# RF TRANSISTORS

FRESH STOCK - NOT SURPLUS  
TESTED - FULLY GUARANTEED

P/N	Rating	2-30 MHz 12V (* - 28V)	Each	Match Pr.
MRF406	20W		\$14.50	\$32.00
MRF412/A	80W		18.00	45.00
MRF421	100W		25.00	56.00
MRF421C	110W		—	60.00
MRF422*	150W		38.00	82.00
MRF426/A*	25W		18.00	42.00
MRF428**	150W		55.00	125.00
MRF433	12.5W		12.00	30.00
MRF435*	150W		42.00	90.00
MRF449/A	30W		12.50	30.00
MRF450/A	50W		14.00	31.00
MRF453/A	60W		15.00	35.00
MRF454/A	80W		16.00	36.00
MRF455/A	60W		12.00	28.00
MRF458	80W		20.00	46.00
MRF460	60W		18.00	42.00
MRF464*	80W		25.00	60.00
MRF466*	40W		18.75	48.00
MRF475	12W		3.00	9.00
MRF476	3W		2.75	8.00
MRF477	40W		11.00	25.00
MRF479	15W		10.00	23.00
MRF485*	15W		6.00	15.00
MRF492	90W		18.00	40.00
SFR2072	75W		15.00	33.00
SFR3662	110W		28.00	60.00
SFR3775	75W		15.50	34.00
SFR3795	85W		16.50	37.00
CD2545	50W		23.00	52.00
SD1076	70W		17.00	40.00
SD1451	50W		15.00	36.00

Selected High Gain Matched Quads Available

VHF/UHF TRANSISTORS				
Rating	MHz	Net Ea.	Match Pr.	
MRF212	10W	136-174	\$16.00	—
MRF221	15W	136-174	10.00	—
MRF222	25W	136-174	14.00	—
MRF224	40W	136-174	13.50	32.00
MRF231	3.5W	66-88	10.00	—
MRF234	25W	66-88	15.00	39.00
MRF237	4W	136-174	3.00	—
MRF238	30W	136-174	12.00	—
MRF239	30W	136-174	15.00	—
MRF240	40W	136-174	18.00	—
MRF245	80W	136-174	28.00	65.00
MRF247	75W	136-174	27.00	63.00
MRF250	50W	27-174	20.00	46.00
MRF260	5W	136-174	7.00	—
MRF261	10W	136-174	9.00	—
MRF262	15W	136-174	9.00	—
MRF264	30W	136-174	13.00	—
MRF607	1.75W	136-174	3.00	—
MRF641	15W	407-512	22.00	—
MRF644	25W	407-512	24.00	54.00
MRF646	40W	407-512	26.50	59.00
MRF648	60W	407-512	33.00	69.00
2N3866*	1W	30-200	1.25	—
2N4427	1W	136-174	1.25	—
2N5591	25W	136-174	13.50	34.00
2N5642*	20W	30-200	13.75	34.50
2N5945	4W	407-512	10.00	—
2N5946	10W	407-512	12.00	—
2N6080	4W	136-174	6.25	—
2N6081	15W	136-174	7.50	—
2N6082	25W	136-174	8.90	—
2N6083	30W	136-174	9.30	24.00
2N6084	40W	136-174	11.75	28.50

Selected, matched finals for Kenwood, Yaesu, Icom, Atlas, etc. Technical assistance and cross-reference information on CD, PT, RF, SRF, SD P/Ns

QUANTITY DISCOUNTS AVAILABLE  
WE SHIP SAME DAY C.O.D./VISA/MC  
INFORMATION AND CALIF. ORDERS: (619) 744-0728  
OUTSIDE CALIF. ORDER DESK: 800-854-1927



## RF PARTS

1320-16 Grand Ave., San Marcos  
California 92069 (619) 744-0728



# High Performance vhf/uhf preamps

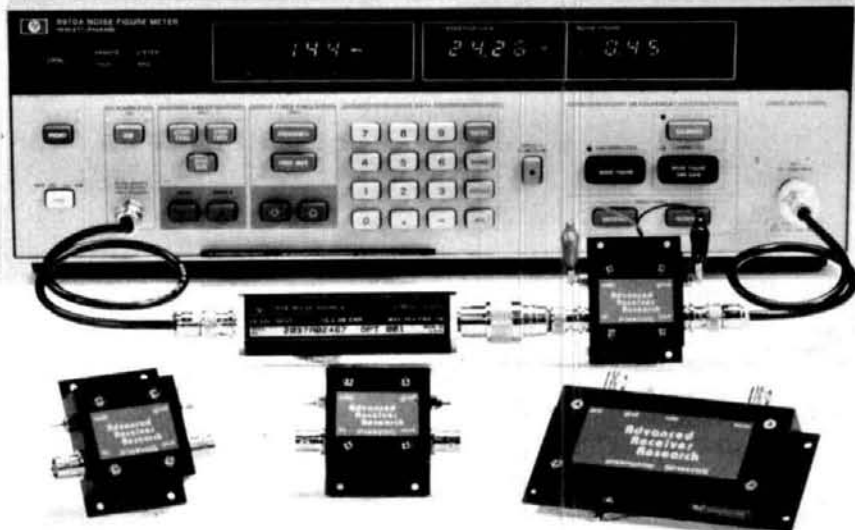

Receive Only	Freq. Range (MHz)	N.F. (dB)	Gain (dB)	1 dB Comp. (dBm)	Device Type	Price
P28VD	28-30	<1.1	15	0	DGFET	\$29.95
P50VD	50-54	<1.3	15	0	DGFET	\$29.95
P50VDG	50-54	<0.5	24	+12	GaAsFET	\$79.95
P144VD	144-148	<1.5	15	0	DGFET	\$29.95
P144VDA	144-148	<1.0	15	0	DGFET	\$37.95
P144VDG	144-148	<0.5	24	+12	GaAsFET	\$79.95
P220VD	220-225	<1.8	15	0	DGFET	\$29.95
P220VDA	220-225	<1.2	15	0	DGFET	\$37.95
P220VDG	220-225	<0.5	20	+12	GaAsFET	\$79.95
P432VD	420-450	<1.8	15	-20	Bipolar	\$32.95
P432VDA	420-450	<1.1	17	-20	Bipolar	\$49.95
P432VDG	420-450	<0.5	16	+12	GaAsFET	\$79.95
<b>Inline (rf switched)</b>						
SP28VD	28-30	<1.2	15	0	DGFET	\$59.95
SP50VD	50-54	<1.4	15	0	DGFET	\$59.95
SP50VDG	50-54	<0.55	24	+12	GaAsFET	\$109.95
SP144VD	144-148	<1.6	15	0	DGFET	\$59.95
SP144VDA	144-148	<1.1	15	0	DGFET	\$67.95
SP144VDG	144-148	<0.55	24	+12	GaAsFET	\$109.95
SP220VD	220-225	<1.9	15	0	DGFET	\$59.95
SP220VDA	220-225	<1.3	15	0	DGFET	\$67.95
SP220VDG	220-225	<0.55	20	+12	GaAsFET	\$109.95
SP432VD	420-450	<1.9	15	-20	Bipolar	\$62.95
SP432VDA	420-450	<1.2	17	-20	Bipolar	\$79.95
SP432VDG	420-450	<0.55	16	+12	GaAsFET	\$109.95

Every preamplifier is precision aligned on ARR's Hewlett Packard HP8970A/HP346A state-of-the-art noise figure meter. RX only preamplifiers are for receive applications only. Inline preamplifiers are rf switched (for use with transceivers) and handle 25 watts transmitter power. Mount inline preamplifiers between transceiver and power amplifier for high power applications. Other amateur, commercial and special preamplifiers available in the 1-1000 MHz range. Please include \$2 shipping in U.S. and Canada. Connecticut residents add 7-1/2% sales tax. C.O.D. orders add \$2. Air mail to foreign countries add 10%. Order your ARR Rx only or inline preamplifier today and start hearing like never before!

## Advanced Receiver Research

Box 1242 • Burlington, CT 06013 • 203 582-9409



✓ 187

## ENGINEERING PROGRAMS FOR THE IBM-PC

RF-CAD ELECTRONICS DESIGN PROGRAM Version 3.51

by Joe Reisert, W1JR and Gary Field, WA1GR  
For IBM PC and compatible computers

This software package has been written by electronic engineers and contains nearly 40 tested and proven programs that will help the Radio Amateur or engineer design many common types of radio circuitry. Emphasis has been placed upon ease of use. Wherever possible, menus of choices with examples are displayed. Should the user be computer literate, the programs are not copy protected so they can be modified to meet your specific requirements. (Full documentation is also provided.) Programs include: Filters, LC, active-LP,HP,BP; Inductor design, toroid, solenoid, straight wire, Matching networks, Crystal oscillators; Microstrip; Transmission lines; Antennas, Yagi-Uda, helix, dish, horn, element scaling, Pi and T attenuators; Also included: Radio Path calculations; FM modulation analysis; Miscellaneous conversions; Geostationary satellite pointing; Moon tracking aids; Receiver noise figure calculations and Spurious receiver response prediction. Requires IBM-PC with at least one floppy drive and 128k of RAM. © 1985

RF-CAD

\$39.95

Please enclose \$3.50 to cover shipping, handling

ham radio magazine

BOOKSTORE GREENVILLE, NH 03048



## STATION MANAGER/ADVANCED A General Purpose Logging Program

Designed for the IBM® PC,® XT,® enhanced PC jr.® Menu driven; prompts for easy use; full color displays; multiple logs (each up to 1,000 entries with user editing), several reporting methods including one by partial call sign.

\$59.00 includes: 90 pg. User's Guide & Diskette (source code included)

\$20.00 — User's Guide only (may be applied to full purchase price)

Ohio residents include sales tax

WATCH FOR STATION MANAGER/CodeTutor ✓ 127  
To be released soon

## OMEGA CONCEPTS

Professional software for the Radio Amateur™

P.O. Box 615  
Troy, OH 45373



T.L. Jones (KB80A)  
Author

IBM is a registered trademark of International Business Machine Corp.

## DRAKE R-4/T-4X OWNERS AVOID OBSOLESCENCE

PLUG-IN SOLID STATE TUBES!

Get state-of-the-art performance.  
Most types available

INSTALL KITS TO UPGRADE PERFORMANCE!

- BASIC Improvement
- Audio Bandpass Filter
- Audio IC Amplifier

TUBES \$23 PPD KITS \$25 PPD

OVERSEAS AIR \$7

SARTORI ASSOCIATES, W5DA  
BOX 832085  
RICHARDSON, TX 75083  
214-494-3093 ✓ 116

## "HAM HOTLINE" THE PROVEN MONEYMAKER

The "Ham Hotline" is a complete mailing list of novice amateur radio operators and current hams who have renewed, upgraded or modified their FCC licenses. These ham enthusiasts have proven to be excellent prospects for radio equipment, accessories and publications.

The Hotline is **UPDATED EVERY TWO WEEKS** with an average of 8,000 names and addresses each month. And, because we know the Hotline is the most up-to-date amateur radio listing available, we'll guarantee 98% deliverability.

Target your sales efforts to your most likely buyers. Call DCC Data Service today and begin your subscription to the "Ham Hotline" . . . the proven moneymaker. ✓ 159

DCC Data Service  
1990 M Street, N.W. Suite 610  
Washington, D.C. 20036

Toll-free 1-800-431-2577

In DC & AK 202-452-1419

# NEW products

## CW manual

This manual (with tape) from Gordon West is a complete guide to assist you in passing the 5, 13<sup>W</sup> and 20 WPM code exams. This is not a Morse Code training or speed building kit, but rather a program of successfully applied exercises to help you understand and deal with problem areas.

*How to Read What You Writ!* addresses many topics including why students do not pass the code exams; how to avoid the common errors; setting goals in code practice; reading the material and finding answers once you've copied the code; dealing with code opposites and letters and numbers that are easily confused; word and sentence techniques; overcoming plateaus, and what to do when test day finally arrives.

*How To Read What You Writ!* is available directly from Loraine McCarthy, Code Programs Manager, Gordon West's Radio School, 315 1/2 Ruby, Balboa Island, California 92662. The price is \$14.95. All orders are shipped by first class mail the same day. (Add \$2.00 postage and handling.) Circle #301 on Reader Service Card.

## Heathkit catalog

Several new products are featured in Heath's new catalog. Included are four new Amateur Radio products: an antenna noise bridge for pinpointing the cause of mismatches in antenna systems; a VLF Converter for receiving the 10 to 500 kHz band between 3.5 MHz and 4.0 MHz on a receiver; an active SWL Antenna for receiving signals between 30 kHz and 30 MHz; and a new touchtone decoder for eliminating extraneous monitor racket.

Six new test instruments have also been added: a new radiation monitor, the RM-4, is a handheld device for measuring radiation in the alpha, beta, gamma, and X-ray spectrums. The new PMK-130 RS-232 hand-held Breakout Box, designed for troubleshooting computer interface problems, allows access to all 25 communication lines. The Heath Digital LC Bridge, model IT-2240 Dual Trace Oscilloscope provides a wide DC to 25 MHz bandwidth.

More than 400 products are available. For a free copy contact Heath Company, Dept. 150-597, St. Joseph, MI. (In Canada, contact Heath Company, 1020 Islington Avenue, Dept. 3100, Toronto, Ontario, M8Z3.

Circle #303 on Reader Service Card.

# Barry Electronics Corp.

WORLD WIDE AMATEUR RADIO SINCE 1950  
Your one source for all Radio Equipment!

For the best buys in town call:  
212-925-7000  
Los Precios Mas Bajos en Nueva York...

KITTY SAYS: WE ARE NOW OPEN 7 DAYS A WEEK.  
Saturday & Sunday 10 to 5 P.M.  
Monday-Friday 9 to 6:30 PM Thurs. to 8 PM  
Come to Barry's for the best buys in town.



Save BIG DOLLARS At Barry's G.W. Birthday Sale  
See You at the LIMARC Flea Market February 16th

### KENWOOD

A-3 Cushcraft  
Hustler KLM  
MTZ Mini-Products  
Mobile  
R-600, R-1000, R-2000, TS-940/SAT  
TS-430S, TR-3600A, TM-2570A/50A/30A  
TW-4000A, Kenwood Service/Repair.  
TH213141AT, TM-211A  
411A & TS-711A/B11A

COMPI-FIRE EXTINGUISHERS  
EXL-5000E RTTY/MOTOR TERMINAL

VoCom/Mirage/Daiwa  
Tokyo Hy Power  
Amplifiers &  
5/8" HT Gain  
Antennas IN STOCK

Soldering Station,  
48 Watts, \$68  
JRC soldering iron in stock  
MICROLOG AIR I, Air Disk,  
SWL, Morse Coach

KANTRONICS  
UTU, Interface II, UTU-XT,  
Challenger, Packet Comm.  
EIMAC  
3-500Z  
572B, 6J56C  
12BY7A &  
4-400A

BIRD  
Wallmeters &  
Elements  
In Stock

AEA 144 MHz  
AEA 220 MHz  
AEA 440 MHz  
ANTENNAS

ONV Safety belts-in stock



FT-ONE, FT-980, FT-757GX, FRG-8800  
FT-726R, FRG-9600, FT-270RH, FT-2700RH

Land Mobile HT  
Midland/Standard  
Wilson Maxon  
Yaesu FT-C 2203, FT-4703  
Icom IC-12 (Marine) M700  
Tempo M-1



Yaesu FTR-2410, Wilson  
ICOM IC-RP 3010 (440 MHz)  
ICOM IC-RP 1210 (1.2 GHz)

Computer Interfaces  
stocked: MFJ-1224  
AEA CP-1, PK-80, DR.DX  
CP-100, PK-64, Dr. QSO,  
Morse University

ALPHA AMPLIFIERS  
Complete Butternut Antenna  
Inventory In Stock!

DIGITAL FREQUENCY COUNTERS  
Pro-Line Engineering  
Model FT-1000: 0-1 GHz 120000  
0-600 MHz 0-1.5 GHz 120000  
Long range Wireless  
Telephone for export in stock

BENCHER PADDLES,  
BALUNS, AUDIO FILTERS,  
IN STOCK  
MIRAGE AMPLIFIERS  
ASTRON POWER SUPPLIES  
Saxton Wire & Cable



IC-R71A, 751, 745, 27A/H, 37A, 47A, R-7000,  
127A, 271A/H, 3200A, 471A/H, 735

SMART PATCH  
100 Single Alignment USA Quality Kit  
Manufacture By: Neal Telephone Great Kit  
Telephone Calls From Mobile To Base Simple  
4-1/2" \$19.95

PRIVATE PATCH III in stock  
CELLULAR 'PHONES STOCKED  
FLUKE 77 Multimeter



Nye MBV-A 3 Kilowatt Tuner

SAITEC  
ST-222/UP  
ST-20T  
ST-442/UP  
HT-7

MFJ Models  
422, 313, 980, & 941D

MURCH Model  
2000 A,  
A.I.S. B  
in stock

SANGEAN Portable Shortwave Radios

HEIL EQUIPMENT  
IN STOCK

Tri Ex Towers  
Hi Gain Towers & Antennas, and  
Fluores will be shipped direct to you FREE of shipping cost

New TEN TEC  
2591HT, Corsair II, Argosy II, Century 22

MAIL ALL ORDERS TO BARRY ELECTRONICS CORP., 512 BROADWAY, NEW YORK CITY, NY 10012.

## New York City's LARGEST STOCKING HAM DEALER COMPLETE REPAIR LAB ON PREMISES

"Aqui Se Habla Espanol"  
BARRY INTERNATIONAL TELEX 12-7670  
MERCHANDISE TAKEN ON CONSIGNMENT  
FOR TOP PRICES  
Monday-Friday 9 A.M. to 6:30 P.M. Thursday to 8 P.M.  
Saturday & Sunday 10 A.M. to 5 P.M. (Free Parking)  
AUTHORIZED DIST. MCKAY DYMEK FOR  
SHORTWAVE ANTENNAS & RECEIVERS  
IRITILEX "Spring St. Station"  
Subways: BMT "Prince St. Station"  
IND - "F" Train-Buy Station"  
Bus: Broadway #6 to Spring St.  
Path--9th St. 4th Ave. Station

Commercial Equipment  
Stocked: ICOM MAXON  
Midland Standard  
Wilson, Yaesu. We serve  
multiprofessionals. Busi-  
nesses, Civil Defense, etc.  
Portables, mobiles,  
bases, repeaters.

We Stock: AEA, ARRL, Alpha, Ameco, Antenna Specialists, Astatic,  
Astron, B & K, B & W, Bash, Bencher, Bird, Butternut, CDE, CES, Collins,  
Communications Spec. Connectors, Covercraft, Cushcraft,  
Daiwa, Dentron, Digimax, Drake, ETO (Alpha), Eimac, Encornum, Heil  
Sound, Henry, Hustler (Newtronics), Hy-Gain, Icom, KLM, Kantronics,  
Larsen, MCM (Daiwa), MFJ, J.W. Miller, Mini-Products, Mirage,  
Newtronics, Nye Viking, Palomar, RF Products, Radio Amateur Callbook,  
Robot, Rockwell Collins, Saxton, Shurk, Telex, Tempo, Ten-Tec,  
Tokyo Hi Power, Trionyx TUBES, W2AU, Waber, Wilson, Yaesu Ham and  
Commercial Radios, Vocom, Vibroplex, Curtis, Tri-Ex, Wacom Duplexers,  
Repeater, Philips Dodge, Fanon Intercoms, Scanners, Crystals, Radio  
Publications.

WE NOW STOCK COMMERCIAL COMMUNICATIONS SYSTEMS  
DEALER INQUIRIES INVITED. PHONE IN YOUR ORDER & BE REIMBURSED  
COMMERCIAL RADIOS stocked & serviced on premises.  
Amateur Radio Courses Given On Our Premises, Call  
Export Orders Shipped Immediately. TELEX 12-7670

ALL SALES FINAL

## TWO NEW ONES FROM ARCSOFT

### QUICK-N-EASY ELECTRONICS PROJECTS



by Bob Green  
Here's a neat book to help while away a rainy afternoon. Contains 40 quick and easy to build projects using commonly found electronic components. Learn-by-doing format is a boon to beginners while advanced builders will enjoy the range of projects included. Projects include: CPD, high VSWR alarm, three battery charger, body bug and sun spotter to name just a few. Also includes list of mail order and local parts supplier suggestions. 1st edition 1985 96 pages

AS-QN Softbound \$7.95

### EASY-TO-BUILD ELECTRONICS PROJECTS

by Bob Green  
40 more electronics projects to work on! Complete plans and schematics and easy-to-locate parts means that you can usually complete these projects in an evening. Projects include: Ad silencer, Muggger bugger, radio-tester, fuse telltale plus 36 more. More practice for the beginner and more fun for the advanced builder. 1st edition 1985 96 pages



AS-ET Softbound \$7.95  
Please enclose \$3.50 to cover shipping and handling

ham radio BOOKSTORE  
GREENVILLE, NH 03048 (603) 878-1441



## LEARN ALL ABOUT TROUBLESHOOTING MICROPROCESSOR-BASED EQUIPMENT AND DIGITAL DEVICES

Attend this 4-day seminar and master the essentials of microprocessor maintenance. Gain a firm understanding of microprocessor fundamentals and learn specialized troubleshooting techniques. Fee is \$695.00

### CURRENT SCHEDULE

- Dallas, TX — Feb 18-21
- Albuquerque, NM — Feb 25-28
- Atlanta, GA — Mar 18-21
- Tampa, FL — Mar 25-28
- Chicago, IL — April 15-18
- Cincinnati, OH — April 21-24

### MICRO SYSTEMS INSTITUTE

Garnett, Kansas 66032  
(913) 898-4695

✓ 133

### SIMPLEX / DUPLEX AUTOPATCH



NOVAX I \$89.95

NOVAX II \$189.95

**IT'S NOT JUST ANOTHER  
AUTOPATCH**

**NOVAX**  
MOBILE CONNECTION

**YOUR OWN PRIVATE AUTOPATCH**

NOVAX interfaces your standard 2 meter, 220-450, etc. base station and telephone, using a high speed scan switching technique so that you can make and receive calls automatically from your automobile or with your HT. Easy installation. Use it as half duplex, using two transceivers, interface HF or other audio sources, remote switch, emergency alert etc. etc.

FEATURES	NOVAX I	NOVAX II
• 3 min. Call duration timer	YES	YES
• Up to 45 sec. activity timer	YES	YES
• Single digit Access Control	YES	NO
• DTMF (Touch Tone)* phone connection	YES	YES
• 4 digit Access Control (Programmable)	NO	YES
• Tail Retract	NO	YES
• LED Display Drive	NO	YES
• Vinyl covered aluminum case	8" x 8" x 2"	10" x 8" x 1 1/2"
• Dynamic Interfaces with Receiver	NO	YES
• Memory Dial System (with 100-01 feature)	NO	YES - \$29.95
• Ring Back Inverse autopaatch	YES	YES
• Price	\$89.95 incl. 170 phone & ring, 100-01 feature & P.T. 100-01	\$189.95 incl. 4-10 & 100-01 & 100-01 feature & P.T. 100-01

N.Y.S. Res. add approx. Sales Tax

To order, send check, money order or MASTERCARD AND VISA ACCEPTED

CURRENT DEVELOPMENT CORPORATION  
E. Carter Rd. - P.O. Box 384  
Westwood, N.Y. 13490  
or Phone 215-333-3119

✓ 161

## MICROCOMPUTER REPEATER CONTROL



**\$129**

✓ 123

Introducing the MICRO REPEATER CONTROLLER RPT-2A, a new concept in LOW COST, EASY TO INTERFACE, microcomputer repeater control. Replace old logic boards with a state of the art microcomputer that adds NEW FEATURES, HIGH RELIABILITY, LOW POWER, SMALL SIZE, and FULL DOCUMENTATION to your system. Direct interface (drop in) with most repeaters. Detailed interface information included. Original MICRO REPEATER CONTROL article featured in QST Dec. 1983.

- Two CW ID Messages
- Time Out Timer
- Pre Timeout Warning MSG
- Post Timeout CW MSG
- Courtesy Beep
- Auxiliary Inputs
- Reconfigurable COR Input
- High Current PTT Interface
- Sine Wave Tone Generator
- Low Power 9.15 VDC @ 200 ma
- Size 3.5" x 3.5"
- All Connectors Included

RPT-2A Kit Only \$129 plus \$3.00 shipping

**PROCESSOR CONCEPTS**  
P.O. BOX 32908  
MINNEAPOLIS, MN 55432  
(616) 780-0472 7pm-10pm evenings

MASTERCARD VISA

CALL OR WRITE FOR FREE CATALOG AND SPECIFICATIONS

# 1986 CALLBOOKS



## The "Flying Horse" has a great new look!

It's the biggest change in Callbook history!  
Now there are 3 new Callbooks for 1986.

The North American Callbook lists the amateurs in all countries in North America plus those in Hawaii and the U.S. possessions.

The International Callbook lists the calls, names, and address information for licensed amateurs in all countries outside North America. Coverage includes Europe, Asia, Africa, South America, and the Pacific area (exclusive of Hawaii and the U.S. possessions).

The Callbook Supplement is a whole new idea in Callbook updates. Published June 1, 1986, this Supplement will include all the activity for both the North American and International Callbooks for the preceding 6 months.

Publication date for the 1986 Callbooks is December 1, 1985. See your dealer or order now directly from the publisher.

☐ North American Callbook  
incl. shipping within USA \$25.00  
incl. shipping to foreign countries 27.60

☐ International Callbook  
incl. shipping within USA \$24.00  
incl. shipping to foreign countries 26.60

☐ Callbook Supplement, published June 1st  
incl. shipping within USA \$13.00  
incl. shipping to foreign countries 14.00

### SPECIAL OFFER

☐ Both N.A. & International Callbooks  
incl. shipping within USA \$45.00  
incl. shipping to foreign countries 53.50

\*\*\*\*\*

Illinois residents please add 6 1/4% sales tax.  
All payments must be in U.S. funds.

### RADIO AMATEUR callbook INC.

Dept. F  
925 Sherwood Dr., Box 247  
Lake Bluff, IL 60044, USA

Tel: (312) 234-6600



✓ 120

### MICROWAVE MODULES TRANSVERTERS & CONVERTERS

MMT1296/144G	1296MHZ, 144IF, 2W, GAASFET	\$319
MMT432/28-S	432MHZ, 28 or 50 IF, 10W	\$269
MMT220/28	220MHZ, 28 or 50 IF, 15W	\$219
MMT144/28	144MHZ, 28 or 50 IF, 15W	\$179
MMT144/28R	144MHZ, 28IF, GAASFET, DBM, 25W	\$299
MMC144/28HP	144MHZ, 28IF, GAASFET, DBM	\$ 79

### SSB ELECTRONIC TRANSVERTERS, PREAMPS, LINEARS

MICROLINE-13	2304MHZ, 144IF, GAASFET, 0.5W	\$319
LT235	1296MHZ, 144IF, GAASFET, 10W	\$599
LT305	902MHZ, 144IF, GAASFET, 10W	\$599
DX2320	2304MHZ, GAASFET, 0.8DB NF	\$159
DX1296	1296MHZ, GAASFET, 0.6DB NF	\$149
MV1296	1296MHZ, GAASFET, 1.0DB NF, SW	\$269
DX432	432MHZ, GAASFET, 0.5 DB NF	\$129
MV432S01	432MHZ, GAASFET, 0.7DB NF, SW	\$239
DX220	220MHZ, GAASFET, 0.4DB NF	\$129
MV220S01	220MHZ, GAASFET, 0.5DB NF, SW	\$229
DX144	144MHZ, GAASFET, 0.3DB NF	\$129
MV144S01	144MHZ, GAASFET, 0.5DB NF, SW	\$229
PA2310	1296/1269MHZ LINEAR, 10W OUT	\$269
SLA-13	2304MHZ LINEAR, 3W OUT	\$279
DCW15A	SEQUENCER for MW PREAMPS	\$ 79

### TUBE AMPLIFIERS

T1296/200	1296MHZ, 200 + W, 2tube	\$275
PA2325	2304MHZ, 25 + 1tube	\$325
WATER COOLING	JACKETS for 2C39, 7289, etc.	\$ 10

ALL PRICES IN U.S. AIR MAIL SHIPPING INCLUDED

## TRANSVERTERS UNLIMITED

BOX 6286 STATION A  
TORONTO, ONTARIO HANS PETERS (VE3CRU)  
CANADA M5W 1P3 (416) 759-5562 EVENINGS

✓ 110

## Electronic Repair Center Servicing

Amateur Commercial Radio

The most complete repair facility on  
the East Coast.

Large parts inventory and factory  
authorized warranty service for  
Kenwood, Icom and Yaesu.

## SEND US YOUR PROBLEMS

Servicing "Hams" for 30 years, no rig  
too old, or new for us.

## HAMTRONICS, INC.

4033 Brownsville Road

Trevose, Pa. 19047

215-357-1400

## DX EDGE

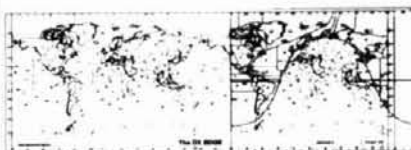

**\$16.95**

GRAYLINE AND LONG PATH  
PREDICTOR

### Great Circle Overlays

20°, 30°, & 40° Latitude (NSS)

\$5 each

\$3 When purchased with slide rule DX Edge

Please enclose \$3.50 shipping and handling

**Ham Radio's Bookstore**  
Greenville, NH 03048

Tell 'em you saw it in HAM RADIO!

# flea market



**RATES** Noncommercial ads 10¢ per word; commercial ads 60¢ per word **both payable in advance.** No cash discounts or agency commissions allowed.

**HAMFESTS** Sponsored by non-profit organizations receive one free Flea Market ad (subject to our editing) on a space available basis only. Repeat insertions of hamfest ads pay the non-commercial rate.

**COPY** No special layout or arrangements available. Material should be typewritten or clearly printed (**not** all capitals) and must include full name and address. We reserve the right to reject unsuitable copy. **Ham Radio** cannot check each advertiser and thus cannot be held responsible for claims made. Liability for correctness of material limited to corrected ad in next available issue.

**DEADLINE** 15th of second preceding month.

**SEND MATERIAL TO:** Flea Market, Ham Radio, Greenville, N. H. 03048.

**SCHEMATIC:** Radio receivers 1920's/60's. Send brand name, model No., SASE Scaramella, PO Box 1, Woonsocket, RI 02895-0001.

**TEMPO SST** mint, with case, ducks, 5/8 gain antenna, charger, S30 amplifier, all manuals \$225 or best offer. Dennis, KA1BYQ. (203) 243-9458 or 528-9756

**THE GOOD SAM HAMS** invite RV operators to check in the Good Sam Ham net 14.240 Sundays 1900Z also 3.880 Tuesdays at 2359Z. Net control N5BDN, Clarksville, IN

**OLD RADIO** transcription discs wanted. Any size, speed. W7FIZ, Box 724 HR, Redmond, WA 98073-0724.

**RTTY-EXCLUSIVELY** for the Amateur Teleprinter. One year \$10.00. Beginners RTTY Handbook \$8.00. PO Box RY, Cardiff, CA 92007.

**IBM-PC RTTY/CW.** CompRtty II is the complete RTTY/CW program for the IBM-PC and compatibles. Virtually any speed ASCII, BAUDOT, CW. Text entry via built-in editor! 10,000 character transmit/receive buffers. Adjustable split screen display. Instant mode/speed change. Hardcopy, diskcopy, break-in buffer, select calling, text file transfer, customizable full screen logging, 24 programmable 1000 character messages. Now with WRU (simple mailbox). Ideal for MARS and traffic handling. Requires 128k PC, XT, AT, PCjr, PC-DOS, serial port, RS-232C T/U \$65. Send call letters (including MARS) with order. Mention Ham Radio Magazine and take \$10 off. David A. Rice, KC2HO, 7373 Jessica Drive, North Syracuse, NY 13212.

**UHF PARTS.** We stock GaAs Fets, Trimmers, and many of those impossible to find parts for the UHF builder. For example: MGF 1202 at \$10.00, Finger Stock at \$7.50 per 16" strip. SASE brings list, Microwave Components, 12126 Cape Cod, Taylor, MI 48180.

**IMRA, International Mission Radio Association** helps mission aries. Equipment loaned. Weekday net, 14.280 MHz, 2-3 PM Eastern. Eight hundred Amateurs in 40 countries. Brother Frey, 1 Pryer Manor Road, Larchmont, New York 10538.

**RUBBER STAMPS:** 3 lines \$4.50 PPD. Send check or MO to G. L. Pierce, 5521 Birkdale Way, San Diego, CA 92117. SASE brings information.

**ELECTRON TUBES:** Receiving, transmitting, microwave... all types available. Large stock. Next day delivery, most cases. Daily Electronics, PO Box 5029, Compton, CA 09224. (213) 774-1255.

**CUSTOM MADE EMBROIDERED PATCHES.** Any size, shape, colors. Five patch minimum. Free sample, prices and ordering information. Hein Specialties, Inc., Dept 301, 4202 N. Drake, Chicago, IL 60618.

**RESISTORS** any value/quantity, 1/4 watt @ \$0.1, 1/2 watt @ \$0.15 (\$1.00 minimum). Quantity discounts, 1,000+. Send wattage(s), value(s), quantity(s), and remittance to T. O. R. C. C. Electronics, box 47148, Chicago, Illinois 60647. (312) 342-9171.

**ELECTRON TUBES** Radio & TV types 75% off list price - huge inventory! Also industrial types. Send for Free Catalog today or call Toll Free (800) 221-5802. Box HC Transleteronics, Inc, 1365 39th Street, Brooklyn, NY 11218

**NEW PACKET RADIO PROGRAM** for IBM PC's. A telecom program for interfacing your PC with your packet controller. Special functions for GLB's: 5 page scrolling screen with cursor control. Two types Binary File Transfers. 300 9600 bps. Keyboard Macros. 50 page manual. Split screens. Windows! Much more. NON COPY PROTECTED. \$49.95 + \$3.00 shipping and handling. Kalt & Associates, Suite#138, 2440 E. Tudor Rd., Anchorage, AK 99507. (907) 248-0133. Write for more info.

**RECONDITIONED TEST EQUIPMENT** \$1.25 for catalog. Waltho, 2697 Nickel, San Pablo, CA 94806.

**PRINTED CIRCUIT BOARDS** and kits for QST articles. Call or write for information. A&A Engineering, 7970 Orchard Drive, Buena Park, CA 90620. (714) 521-4160.

**R-390A RECEIVER.** 5-30 MHz all modes, 4 mechanical filters, meters sealed (Government removed, operation unaffected): complete/checked \$195, complete/repairable \$115, spare parts unit (80% complete) \$65. CPRC 26 Manpack Radio (described in March 1985 Ham Radio), transceivers 46-54 MHz FM, with battery box, antenna, crystal, handset: \$22.50 apiece, \$42.50/pair. Info SASE. CPRC-26 add \$4/unit shipping. R 390A shipping charges collect. Baytronics, Dept. HR, Box 591, Sandusky, OH 44870. (419) 627-0460 evenings.

**CIRCUIT BOARDS** Guaranteed lowest quotes and Free twelve hour prototypes. Single and double sided boards. Small through large production quantities. Mail specifications. Hobbyists - any schematic 6" x 9" maximum, etched on a 3" x 4" board \$1.50. (larger boards \$2.50). Send remittance and schematic or art work or, print your own circuit boards. Kits of all sizes. Guaranteed lowest prices. Basic kit \$2.75. Materials for two 3" x 4" boards (included) or SASE for catalog. T. O. R. C. C. Electronics, Box 47148, Chicago, Illinois 60647. (312) 342-9171.

**PACKET/ASCII/BAUDOT/CW** for IBM-PC. SASE to: Emile Alline, 773 Rosa, Metairie, LA 70005.

**PRINTED CIRCUIT BOARDS** TORCCC Electronics will print any schematic, 6" x 9" maximum, on a circuit board for \$1.50 (larger schematics - add \$1.25 per additional 50 square inches). Send check and schematic to: TORCCC Electronics, 2161 North California, Chicago, Illinois 60647.

**WANTED** NC400 receiver. Any condition W2PUA, 112 Tilford Road, Somerdale, NJ 07083. (609) 783 4175

**DRAKE! DRAKE! DRAKE!** Complete station with late model TR7A/DR7 transceiver and R7A receiver, speech processor, speaker, power supply, fans, cross connect cables, manual. Asking \$1550. Guaranteed excellent condition or I pay for repair. Gary Jordan, WA6TKT, 1012 Olmo Court, San Jose, CA 95129 (408) 257-2222.

**CABLE TV CONVERTERS/DESCRAMBLERS.** Guaranteed lowest prices in US. Jerrold, Hamlin, Zenith. Many others. Lowest dealer prices! Orders shipped within 24 hours! Complete illustrated catalog, \$2.00. Pacific Cable Co., Inc., 7325 1/2 Reseda Blvd, #1009, Reseda, CA 91335. (818) 716 5914.

**WANTED: NEED URGENTLY** schematic operations manual for Honeywell 6869 VLF Receiver. H. Weber, 2605 W. 82nd Place, Chicago, IL 60652.

**CHASSIS** and cabinet kits. SASE K3IWK.

**IC-25A FOR SALE:** \$225 or best offer. Good condition, used only as a mobile radio. Call Craig (603) 878 1441, 9.5 EST. M-F only.

**DIGITAL AUTOMATIC DISPLAYS.** All transceivers. Six 1/2" digits. 5" wide by 1-1/4" by 9" cabinet! Send \$1.00 for information. Be specific. Grand Systems, POB 2171, Blaine, Washington 98230.

**CB to 10M CONVERSIONS.** FM kits, frequency modification hardware, books, plans, high performance CB accessories. Free catalog CBCI, Box 31500HR, Phoenix AZ 85046. (602) 996 8700.

**CABLE TV CONVERTERS & EQUIPMENT:** Plans and parts. Build or buy. FREE information. C & D Electronics, PO Box 1402, Dept. HR, Hope, AR 71801.

**R1W-19** 432 MHz beams by K3IPW. SASE for information.

**HP606B SIGNAL GENERATOR.** 50 kHz - 65 MHz. Excellent condition, with manual. \$290. VE3EAA, Box 2980, Str. D, Ottawa, Ontario K1P 5W9.

**FOR SALE:** Bearcat 160, 16 channel, 5 band programmable scanner with memory backup. Needs IC. \$109.00. (812) 342-6740.

**TEST EQUIPMENT:** Lab calibrated signal generators: HP 8640B 500 kHz thru 1024 MHz, AM/FM, with options 002, 003, and 323 portable field carrying case \$5,500.00. Marconi HF 10668/B, 10 MHz thru 470 MHz AM/FM, \$550.00, HP 606A 50 kHz thru

65 MHz \$375.00, military TS-510A 10 MHz thru 420 MHz \$295.00, military URM 25D, 10 kHz thru 50 MHz \$245.00, URM 26B, 4 MHz thru 405 MHz \$245.00, HP: Boonton 202H, 54 MHz thru 216 MHz AM/FM \$275.00, HP 614A, 900 to 2100 MHz \$345.00, HP 808E 10 MHz thru 480 MHz \$495.00, HP 628A 15 GHz thru 21 GHz \$650.00. Frequency counter HP 5245L with HP 5253B plug-in, range 0-500 MHz \$375.00. We accept Visa, M/C, check. Satisfaction guaranteed. Phone Bill Slep. (704) 524 7519. Slep Electronics, Highway 441, Otto, NC 28763.

**RESISTORS** any value/quantity, 1/4 watt @ \$0.1, 1/2 watt @ \$0.15 (\$1.00 minimum). Quantity discounts, 1,000+. Send wattage(s), value(s), quantity(s), and remittance. T. O. R. C. C. Electronics, Box 47148, Chicago, Illinois 60647. (312) 342-9171

**COLLECTION** of 40 Antique Radios and 22 Ham and Drum Speakers. Many other items and parts all working. Blair Drey, KA800H, Elsie, MI 48831. (517) 862-5228

## COMING EVENTS

### Activities — "Places to go . . ."

**CALIFORNIA:** FCC exams. Novice Extra. Sunnyvale VEC ARC (408) 255-9000 24 hour. 73, Gordon, W6NLG, VEC

**PENNSYLVANIA:** The Mercer County Amateur Radio Club invites Amateurs to socialize and exchange views at its "How To" seminar, March 22, 9 AM to 4:30 PM, Hermitage Middle School opposite Shenandoah Valley Mall, Rt. 18, Hermitage. License exams, Novice through Extra, will be given. Examinees and those under 18 years admitted free. For others admission is \$2.00. Call in on 147.75.15. For details SASE to MCARC, Box 996, Sharon, PA 16146.

**MASSACHUSETTS:** The Mt. Tom Amateur Repeater Association is having its annual Flea Market, March 2, Knights of Columbus Elder Council 69 on Granby Road, Chicopee. Doors open 8 AM to 3 PM. Food available. Reserved tables \$7.00. At the door \$8.00. Entrance fee \$1.00. Ladies and children under 12 free. For reservations: MTARA, PO Box 3494, Springfield, MA 01101.

**MINNESOTA:** The Robbinsdale Amateur Radio Club's 5th annual Midwest Madness Hobby Electronics Show, February 22, Totino Grade High School, 1350 Garden Avenue NE, Fridley, MN (suburb of Minneapolis). Admission \$3.00 advance; \$4.00 at the door. 8' flea market tables \$8.00, 1/2 tables \$4.00. Dealers, flea market, computers, satellite TV, packet radio. Talk in on 147.60.00 KJLTC repeater and 146.52 simplex. To register send SASE with fees to Robbinsdale ARC, PO Box 22613, Robbinsdale, MN 55422 or call Bob (612) 533 7354. FCC exam registration send completed Form 610, photocopies of current license and credit card plus \$4.00 payable to ARRL/VEC to: Neil McMillin, 1132 97th Place, Maple Grove, MN 55369 by January 22, 1986. Limited walk-ins.

**KENTUCKY:** Annual Glasgow Swapfest, Saturday, February 22, 8 AM at Glasgow Flea Market Building, 2 miles south of Glasgow off Highway 31E. Free parking, free coffee and a friendly gathering of hams. Admission \$2. No extra charge for exhibitors. One free table per exhibitor. Extra tables \$3.00 each. Talk in on 146.34.94. For information: N4HCO, Rt 4, Box 354, Glasgow, KY 42141.

**MASSACHUSETTS:** The Norwood ARC will hold its annual Flea Market, Saturday, February 22, Norwood Junior High School South, Washington Street. Dealer tables \$10.00. Setup 8 AM. General admission \$2.00. Open 9 AM. Plenty of free parking and facilities for the handicapped. For information or table reservations: Stan Cottrell, WA1NCV (617) 762 5184. Talk in on 146.520 and 146.895.

**ILLINOIS:** The Sterling Rock Falls Amateur Radio Society's 26th annual Hamfest, March 9, Sterling High School Fieldhouse, 1608 Fourth Avenue, Sterling. Distributors, dealers, large flea market and demonstration of Packet Radio. Free parking and space for self contained RV's. Doors open 7:30 AM. Tickets \$3.00 advance; \$4.00 at the door. Commercial tables \$5.00. Others \$3.00. For tickets, tables or information: Sue Peters, KA0GMR, PO Box 521, Sterling, IL 61081. (815) 625-9262. Talk in W9MEP 146.25/85.

**MASSACHUSETTS:** The MIT UHF Repeater Association and the MIT Radio Society offer monthly Ham Exams. All classes Novice to Extra. Wednesday, February 19, 1986, 7 PM, MIT Room 1 134, 77 Mass Ave, Cambridge, MA. Reservations requested 2 days in advance. Contact Ron Hoffmann (617) 253 5820/646-1641 or Craige Rodgers at 225 6616. Exam fee \$4.00 BRN copy of current license, 2 forms of picture ID and completed form 610 (available from FCC in Boston, 223-6609).

**VIRGINIA:** The Vienna Wireless Society will hold its 13th annual Winterfest, February 23, 8 AM, Vienna Community Center, 120 Cherry St., Vienna. Exhibits and demonstrations of new and used Amateur Radio equipment. Tailgating in the "Frostbite" parking lot. Refreshments available. For information: John Arnold, N4IXD, Chairman, 255 2076.

### Operating Events — "Things to do . . ."

**North Carolina QSO Party** sponsored by the Alamance ARC, K4EG, 1400Z February 1 to 0500Z February 2, CW and phone. Work stations once per band/mode. Mobsiles as they change county. Exchange RS(T) and ARRL section. Mail logs by 3/1/86 to North Carolina QSO Party, c/o K4EG, PO Box 3064, Burlington, NC 27215.



**CHARGE**  
**YOUR CLASSIFIED ADS**

**to your MC or VISA, write or call**  
**HAM RADIO MAGAZINE**  
**Greenville, NH 03048**  
**(603) 878-1441**



## Foreign Subscription Agents for Ham Radio Magazine

Ham Radio Austria  
Karin Ueber  
Postfach 2454  
D-7850 Loerrach  
West Germany

Ham Radio Belgium  
Stereohouse  
Brusselsseleeweg 416  
B-9218 Gent  
Belgium

Ham Radio Holland  
Postbus 413  
NL-7800 Ar Emmen  
Holland

Ham Radio Europe  
Box 2084  
S-194 02 Upplands Vasby  
Sweden

Ham Radio France  
SM Electronic  
20 bis, Ave des Clairons  
F-89000 Auxerre  
France

Ham Radio Germany  
Karin Ueber  
Postfach 2454  
D-7850 Loerrach  
West Germany

Canada  
Send orders to  
Ham Radio Magazine  
Greenville, NH 03048 USA  
Prices in Canadian funds  
1 yr \$29.95, 2 yrs \$53.30  
3 yrs \$75.40

Ham Radio Italy  
Via Manago 15  
I-20134 Milano  
Italy

Ham Radio Switzerland  
Karin Ueber  
Postfach 2454  
D-7850 Loerrach  
West Germany

Ham Radio England  
c/o R S G B  
Alma House  
Crabome Road  
Potters Bar  
Herts EN6 3JW  
England



*Ham Radio's guide to help you find your local dealer*

## California

**C & A ROBERTS, INC.**  
18511 HAWTHORN BLVD.  
TORRANCE, CA 90504  
213-370-7451  
24 Hour: 800-421-2258  
Not The Biggest, But The Best —  
Since 1962.

**FONTANA ELECTRONICS**  
8628 SIERRA AVENUE  
FONTANA, CA 92335  
714-822-7710  
714-822-7725  
The Largest Electronics Dealer in San Bernardino County.

**JUN'S ELECTRONICS**  
3919 SEPULVEDA BLVD.  
CULVER CITY, CA 90230  
213-390-8003  
800-882-1343 Trades  
Habla Espanol

## Colorado

**COLORADO COMM CENTER**  
4262 LOWELL BLVD.  
DENVER, CO 80211  
(303) 433-3355  
(800) 227-7373  
Stocking all major lines  
Kenwood, Yaesu, Encomm

## Connecticut

**HATRY ELECTRONICS**  
500 LEDYARD ST. (SOUTH)  
HARTFORD, CT 06114  
203-527-1881  
Call today. Friendly one-stop shopping  
at prices you can afford.

## Delaware

**AMATEUR & ADVANCED COMMUNICATIONS**  
3208 CONCORD PIKE  
WILMINGTON, DE 19803  
(302) 478-2757  
Delaware's Friendliest Ham Store.

**DELAWARE AMATEUR SUPPLY**  
71 MEADOW ROAD  
NEW CASTLE, DE 19720  
302-328-7728  
800-441-7008  
Icom, Ten-Tec, Microlog, Yaesu,  
Kenwood, Santec, KDK, and more.  
One mile off I-95, no sales tax.

## Florida

**AMATEUR ELECTRONIC SUPPLY**  
1898 DREW STREET  
CLEARWATER, FL 33575  
813-461-4267  
Clearwater Branch  
West Coast's only full service  
Amateur Radio Store.  
Hours M-F 9-5:30, Sat. 9-3

**AMATEUR ELECTRONIC SUPPLY**  
621 COMMONWEALTH AVE.  
ORLAND, FL 32803  
305-894-3238  
Fla. Wats: 1 (800) 432-9424  
Outside Fla: 1 (800) 327-1917  
Hours M-F 9-5:30, Sat. 9-3

## Georgia

**DOC'S COMMUNICATIONS**  
702 CHICKAMAUGA AVENUE  
ROSSVILLE, GA 30741  
(404) 866-2302  
ICOM, Yaesu, Kenwood, KDK, Bird...  
9AM-5:30PM  
We service what we sell.

## Hawaii

**HONOLULU ELECTRONICS**  
819 KEEAUMOKU STREET  
HONOLULU, HI 96814  
(808) 949-5564  
Serving Hawaii & Pacific area for 53  
years.

## Illinois

**ERICKSON COMMUNICATIONS, INC.**  
5456 N. MILWAUKEE AVE.  
CHICAGO, IL 60630  
312-631-5181  
Hours: 9:30-5:30 Mon, Tu, Wed & Fri;  
9:30-8:00 Thurs; 9:00-3:00 Sat.

## Indiana

**THE HAM STATION**  
220 N. FULTON AVE.  
EVANSVILLE, IN 47710  
812-422-0231  
Discount prices on Ten-Tec, Cubic,  
Hy-Gain, MFJ, Azden, Kantronics,  
Santec and others.

## Massachusetts

James Millen Components by  
**ANTENNAS ETC.**  
16 HANSOM ROAD  
ANDOVER, MA 01810  
617-475-7831  
Bezels, binding posts, capacitors, con-  
densers, chokes, coils, ceramics, H.V.  
connectors, plate caps, hardware  
knobs, dials, scopes and grid dippers.  
Inquire SASE or visit.

**TEL-COM, INC.**  
675 GREAT ROAD, RTE. 119  
LITTLETON, MA 01460  
617-486-3400  
617-486-3040  
The Ham Store of New England  
You Can Rely On.

## Michigan

**ENCON PHOTOVOLTAICS**  
Complete Photovoltaic Systems  
27600 Schoolcraft Rd.  
Livonia, Michigan 48150  
313-523-1850  
Amateur Radio, Repeaters, Satellite,  
Computer applications.  
Call Paul WD8AHO

## Minnesota

**TNT RADIO SALES**  
4124 WEST BROADWAY  
ROBBINSDALE, MN 55422 (MPLS/ST.  
PAUL)  
TOLL FREE: (800) 328-0250  
In Minn: (612) 535-5050  
M-F 9 AM-6 PM  
Sat 9 AM-5 PM  
Ameritron, Bencher, Butternut, Icom,  
Kenwood

## Missouri

**MISSOURI RADIO CENTER**  
102 NW BUSINESS PARK LANE  
KANSAS CITY, MO 64150  
(800) 821-7323  
Missouri: (816) 741-8118  
ICOM, Kenwood, Yaesu  
Same day service, low prices.

## Nevada

**AMATEUR ELECTRONIC SUPPLY**  
1072 N. RANCHO DRIVE  
LAS VEGAS, NV 89106  
702-647-3114  
Dale Porray "Squeak," AD7K  
Outside Nev: 1 (800) 634-6227  
Hours M-F 9-5:30, Sat. 9-3

## New Jersey

**KJI ELECTRONICS**  
66 SKYTOP ROAD  
CEDAR GROVE, NJ 07009  
(301) 239-4389  
Gene K2KJI  
Maryann K2RVH  
Distributor of: KLM, Mirage, ICOM, Lar-  
sen, Lunar, Astron. Wholesale - retail.

**Dealers:** *YOU SHOULD BE HERE TOO!*  
*Contact Ham Radio now for complete details.*

## Amateur Radio Dealer

### New York

#### BARRY ELECTRONICS

512 BROADWAY  
NEW YORK, NY 10012  
212-925-7000  
New York City's Largest Full Service  
Ham and Commercial Radio Store.

#### VHF COMMUNICATIONS

915 NORTH MAIN STREET  
JAMESTOWN, NY 14701  
716-664-6345  
Call after 7 PM and save! Supplying all  
of your Amateur needs. Featuring ICOM  
"The World System." Western New  
York's finest Amateur dealer.

### North Carolina

#### F & M ELECTRONICS

3520 Rockingham Road  
Greensboro, NC 27407  
1-919-299-3437  
9AM to 7PM Closed Monday  
ICOM our specialty — Sales & Service

### Ohio

#### AMATEUR ELECTRONIC SUPPLY

28940 EUCLID AVE.  
WICKLIFFE, OH 44092 (Cleveland Area)  
216-585-7388  
Ohio Wats: 1 (800) 362-0290  
Outside Ohio: 1 (800) 321-3594  
Hours M-F 9-5:30, Sat. 9-3

#### DEBCO ELECTRONICS, INC.

3931 EDWARDS RD.  
CINCINNATI, OHIO 45209  
(513) 531-4499  
Mon-Sat 10AM-9PM  
Sun 12-6PM  
We buy and sell all types of electronic  
parts.

#### UNIVERSAL AMATEUR RADIO, INC.

1280 AIDA DRIVE  
REYNOLDSBURG (COLUMBUS), OH  
43068  
614-866-4267  
Featuring Kenwood, Yaesu, Icom,  
and other fine gear. Factory author-  
ized sales and service. Shortwave  
specialists. Near I-270 and airport.

### Pennsylvania

#### HAMTRONICS,

DIV. OF TREVISE ELECTRONICS  
4033 BROWNSVILLE ROAD  
TREVISE, PA 19047  
215-357-1400  
Same Location for over 30 Years.

#### LaRUE ELECTRONICS

1112 GRANDVIEW STREET  
SCRANTON, PENNSYLVANIA 18509  
717-343-2124  
ICOM, Bird, Cushcraft, Beckman,  
Larsen, Amphenol, Astron, Belden,  
Antenna Specialists, W2AU/W2VS,  
Tokyo Hy-Power Labs, WELZ, Daiwa,  
Sony, Saxton, Vibroplex, Weller.

#### THE VHF SHOP

16 S. MOUNTAIN BLVD., RTE. 309  
MOUNTAINTOP, PA 18707  
717-474-9399  
Lunar, Microwave Modules, ARCOS,  
Astron, KLM, Tama, Tonna-F9FT,  
UHF Units/Parabolic, Santec, Tokyo  
Hy-Power, Dentrion, Mirage,  
Amphenol, Belden

### Texas

#### MADISON ELECTRONICS SUPPLY

3621 FANNIN  
HOUSTON, TX 77004  
713-520-7300  
Christmas?? Now??

### Wisconsin

#### AMATEUR ELECTRONIC SUPPLY

4828 W. FOND DU LAC AVE.  
MILWAUKEE, WI 53216  
414-442-4200  
Wisc. Wats: 1 (800) 242-5195  
Outside Wisc: 1 (800) 558-0411  
M-F 9-5:30 Sat 9-3

**SAVE SAVE**  
**SAVE SAVE**

1983-84

ARRL

**AMATEUR RADIO  
CALL DIRECTORY**

WAS \$15.75

**NOW \$4.95**

**SAVE \$10.80**



Please add \$3.50 to cover  
shipping and handling



**Ham Radio's Bookstore**  
GREENVILLE, NH 03048

# FREE SATELLITE TV



800-4-SATMAN



## NEW 24 Page Buyer's Guide With Guaranteed Lowest Prices

- Explains all about FREE 100 channel Satellite TV and how to shop for an earth station!
- Lists GUARANTEED LOWEST PRICES...we will not be undersold, save 30-50% over local dealer prices!
- Tells how to easily and quickly Install-Your-Own earth station and save \$400 or more!
- Shows how to demonstrate and sell earth stations from your home and earn extra money!

uniden

ALCOA

netics

Panasonic

CHAMPARAL

Falmpico, Inc.

The new SATMAN Buyer's Guide is a necessity for any prospective or current earth station owner who wants to save big money on name brand satellite products and also earn some extra money. Buy direct, Do-It-Yourself, and save with SATMAN. Toll free ordering, no sales tax (IL only), major credit cards accepted, huge in-stock inventories available, and fast UPS shipping anywhere in U.S. Check with SATMAN before you buy... We will not be undersold! Call now for your free 24 page SATMAN Buyer's Guide.

**1-800-4-SATMAN**

1-309-692-9582 Illinois



**SATMAN**

5017 N. MELODY • PEORIA, IL 61614 • 1-800-4-SATMAN

clip and save

Uncle Ben says...

**"I give you  
much more than  
just the lowest price..."**

When you get that exciting new piece of equipment *from me*, you know you are going to be completely happy... I see to it, personally! I also give you earliest delivery, greatest trade-in allowances, my friendly assistance in every possible way.

Just ask any of the many thousands of hams all over the world who have been enjoying my friendly good service for over a half a century.

73, Uncle Ben, W2SOH



"Uncle Ben" Snyder, W2SOH  
the head man of  
**HARRISON**  
"HAM HEADQUARTERS,  
USA" ...Since 1925!

• **CALL ME...**

(516) 293-7995

**HARRISON**  
**HAS THEM ALL!**  
**KENWOOD**

• **WRITE ME...**

For my prompt,  
personal reply.

• **SEE ME...**

At one of the world's largest  
Ham Supply Centers!



Kenwood TH21AT, 31AT, 41AT



Kenwood TM-2570A



Kenwood TS-940S



Kenwood TS-430S



Kenwood TR-2600, TR-3600



Kenwood TS-711A (2m)  
TS-811A (70 cm)



**HARRISON** RADIO

...Since 1925!

**CHARGE IT!**

**"HAM HEADQUARTERS, USA"**

2263 Route 110 (at Smith St.)  
E. Farmingdale, NY 11735

1-(516) 293-7995



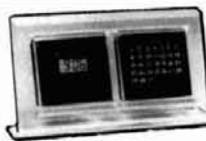

RECEIVE THIS LCD CALENDAR/CLOCK FREE WITH YOUR SUBSCRIPTION

## WHAT'S REALLY HAPPENING IN HOME SATELLITE TV?

# STV<sup>®</sup> THE HOME SATELLITE TELEVISION MAGAZINE

A monthly of 100-plus pages—has everything you need to know about where to find equipment, how to install it, system performance, legal viewpoints, and industry insights! With your subscription to STV<sup>®</sup> you will receive a FREE LCD Calendar/Clock.

- Only \$19.95 per year (12 monthly issues)
- \$1.00 for sample copy

IF YOU HAVE A SATELLITE SYSTEM, THEN YOU REALLY NEED ...



# OnSat

The best in satellite programming! Featuring: ★All Scheduled Channels ★Weekly Updated Listings ★Magazine Format ★Complete Movie Listing ★All Sports Specials ★Prime Time Highlights ★Specials Listing and ★Programming Updates!

- Only \$45.00 per year (52 weekly issues)
- 2 Years \$79.00 (104 weekly issues)
- \$1.00 for sample copy

Visa<sup>®</sup> and MasterCard<sup>®</sup> accepted (subscription orders only). All prices in US funds. Write for foreign rates.

Send this ad along with your order to:

**STV<sup>®</sup>/OnSat<sup>®</sup>**

P.O. Box 2384—Dept. HR • Shelby, NC 28151-2384

**SUBSCRIPTION CALLS ONLY  
TOLL FREE 1-800-438-2020**

## AMATEUR TELEVISION



### KPA5 1 WATT 70 CM ATV TRANSMITTER BOARD

- **APPLICATIONS:** Cordless portable TV camera for races & other public service events, remote VCR, etc. Remote control of R/C airplanes or robots. Show home video tapes, computer programs, repeat SSTV to local ATVs. DX depends on antennas and terrain typ. 1 to 40 miles.
- **FULL COLOR VIDEO & SOUND** on one small 3.25x4" board.
- **RUNS ON EXTERNAL 13.8 VDC** at 300 ma supply or battery.
- **TUNED WITH ONE CRYSTAL** on 426.25, 434.0, or 439.25 mHz.
- **2 AUDIO INPUTS** for a low Z dynamic and line level audio input found in most portable color cameras, VCRs, or home computers.
- **APPLICATION NOTES & schematic** supplied for typical external connections, packaging, and system operation.
- **PRICE ONLY \$159** delivered via UPS surface in the USA. Technician class amateur license or higher required for purchase and operation.

**WHAT IS REQUIRED FOR A COMPLETE OPERATING SYSTEM?** A TV set with a TVC-2 or TVC-4 420-450 mHz to channel 3 downconverter, 70 cm antenna, and coax cable to receive. Package up the KPA5, add 12 to 14 vdc. antenna, and any TV camera, VCR, or computer with a composite video output. Simple, eh?

**CALL OR WRITE FOR OUR COMPLETE CATALOG & more info** on atv downconverters, antennas, cameras, etc., or who is on in your area.

TERMS: Visa, Mastercard, or cash only UPS COD by telephone or mail. Telephone orders & postal MO usually shipped within 2 days, all other checks must clear before shipment. Transmitting equipment sold only to licensed amateurs verified in 1984 Callbook, Calif. include sales tax.

(818) 447-4565 m-f 8am-6pm pst.

**P.C. ELECTRONICS**  
Tom W6ORG Maryann WB6YSS



2522 Paxson Lane  
Arcadia CA 91006

✓ 126



INT'L MONTHLY MAGAZINE BY AND FOR ACTIVE RADIOAMATEURS

## RADIOSPORTING

Dedicated to quality and sportsmanship in amateur radio operating. Fresh, timely, practical and down to earth reading for little pistols and big guns written by world's best in their fields.

DX news, DXpeditioning, propagation, contest rules and results, emergency - traffic, FCC news, new products, antenna and technical articles, equipment reviews and modifications, computer programs, YL, RTTY, VHF, UHF, ATV, SSTV, AMTOR, classified ads and much more.

*"Your publication is superb! Keep it up!"*

Joe Reisert, W1JR

*"Your W2PV articles are priceless. Your magazine is super!"*

Rush Drake, W7RM

*"Let me congratulate you on a very impressive magazine. Just what I've been looking for as a DXer and Contester!"*

Dick Moen, N7RO

*"RADIOSPORTING, once received, cannot be tossed aside until it is read from cover to cover. Then reviewed again and again."*

Chas Browning, W4PKA

Subscription rates: 1 year USA \$ 16, Canada \$ 22,  
Overseas US\$ 19

Membership in International Radio Sport Assn \$ 4/yr

TRY US! PHONE OR SEND YOUR QSL CARD FOR SAMPLE COPY

**RADIOSPORTING** Tel. (416) 438-6313  
Box 65, Don Mills, ON, M3C 2R6, Canada

✓ 119

✓ 112

# EGE Has Reduced Prices

**ICOM DAY  
FEB 22**

## Snow Tellin' What

**ICOM** HF TRANSCEIVERS HANDHELDS

**KENWOOD** HF TRANSCEIVERS

**NEW ICOM** RECEIVERS

**MARINE** VHF/USB

**REPEATERS**

**COMMERCIAL LAND MOBILE** AUTHORIZED DEALER

**ACCESSORIES**

**NEW SERVICE DEPARTMENT**

**ICOM DAY FEB 22**

Hard to get through on our 800 number?

ATM PHONE CENTER

SEARCH: UNIDEN, SONY, PANASONIC SWL, COMRACK, MIDLAND CB, WHISTLER

SOFTWARE: KENWOOD's SuperPack, ICOM's AutoScan, Yaesu's Memory Search, Kenwood's Memory Search, ICOM's Memory Search

PACKAGES: ICOM's Super Pack, Yaesu's Memory Search, Kenwood's Memory Search, ICOM's Memory Search

TE SYSTEMS: ICOM's Super Pack, Yaesu's Memory Search, Kenwood's Memory Search, ICOM's Memory Search

HF AMPLIFIERS: ICOM's Super Pack, Yaesu's Memory Search, Kenwood's Memory Search, ICOM's Memory Search

ICOM'S SUPER SPECIAL

For Orders and Quotes Call Toll Free: 800-336-4799  
Virginia Orders and Quotes Call Toll Free: 800-572-4201

## We're Sellin' ANTENNAS & TOWERS

**SANTEC** HF TRANSCEIVERS

**YAESU** VHF/USB

**NEW SCANNER**

**HANDHELD**

**COMMERCIAL LAND MOBILE** AUTHORIZED DEALER

**SWL RECEIVER**

**TEN-TEC** HF TRANSCEIVERS

**POLARIS MARINE ELECTRONICS** AND RELATED LAND MOBILE

**UNARCO-ROHN**

**ANTENNAS FOR OSCAR**

**TELETYPE HEADPHONES**

**PRECISION**

For Orders and Quotes Call Toll Free: 800-336-4799  
Virginia Orders and Quotes Call Toll Free: 800-572-4201

**Call Toll Free for Orders & Quotes: 800-336-4799**  
In Virginia: 800-572-4201

✓ 154

### CASE HISTORY!

For 2AT/3AT/4AT w/standard batt.  
from **delta zulu**

**\$20.95**  
+ shipping made in U.S.A.  
90 day limited warranty

**VISA**

**G.O.D. \$2**

See through keypad window and instant access to all switches front, top, back plus unique zippered battery door. Fits with or w/o ICOM clip. Looks, feels and fits great. Black or burgundy tailored vinyl. Call (617) 599-3090.

Crowley Mfg. Co. 95 Federal St. Lynn MA 01905

✓ 163

### SYNTHESIZED SIGNAL GENERATOR

**MADE IN USA**

**MODEL SG-100F**  
**\$429.95 delivered**

- Covers 100 MHz to 199.999 MHz in 1 kHz steps with thumbwheel dial
- Accuracy +/- 1 part per 10 million at all frequencies
- Internal FM adjustable from 0 to 100 kHz at a 1 kHz rate
- External FM input accepts tones or voice
- Spurs and noise at least 60 dB below carrier
- Output adjustable from 5-500 mV at 50 Ohms
- Operates on 12 Vdc @ 1/2 Amp
- Available for immediate delivery • \$429.95 delivered
- Add-on accessories available to extend freq range, add infinite resolution, AM, and a precision 120 dB attenuator
- Call or write for details • Phone in your order for fast COD shipment.

**VANGUARD LABS** ✓ 104  
196-23 Jamaica Ave., Hollis, NY 11423  
Phone: (718) 468-2720 Mon. thru Thu.



**CURLYCODE**

- Exciting NEW learning experience lets the code RHYTHM build "unforgettable" shapes in your mind's eye. Sounds ADD to the shape you already SEE: NO never change your mind about them! Shapes ARE the characters: write them!
  - BEGINNERS: no "study" because: Only EIGHT shapes give you HALF of EVERYTHING and nearly ALL the LETTERS. Know EVERYTHING! only 2 more endings each!
  - EXPERTS: break your "learning plateau" by letting shapes form at "any" speed.
  - CLUBS: 20% discount on 10 or more sets.
  - PRICE: Complete set (Manual, Wall chart, Pocket card, Beginner's chart): \$11.50  
Manual alone (no discount): \$6.50
- hinds eye**  
Hinds eye Publications, Dept. H10  
P.O. Box 1310, McLean, VA 22101

✓ 131

# THE GUERRI REPORT

by Ernie Guerri, W6MGI

## millimeter waves

### Part I: the move to higher frequencies

For most Amateurs, the notion of moving to higher frequency bands means operating at or above 144 MHz. A few brave pioneers work in the microwave region — and have precious few contacts to show for it. We could be tempted to forget that for more than 40 years, there has been an avalanche of effort devoted to the development of microwave hardware and systems.

For the purposes of this discussion, "microwaves" will mean the region above 2 GHz — that is, up to about 30 GHz. This is the domain where lumped circuits fail to have physical implementation and where waveguide replaces coax in many low-loss or high-power applications. While military uses were the principal motivator for early work, commercial applications are now the driving force in the region from 2 to 18 GHz.

Band crowding is already a major issue in the microwave region. By the mid-1960s, the military had found use for nearly everything up to about 20 GHz. Then came the demands for commercial satellite uses, followed by the expansion of terrestrial links to take advantage of all the information the satellites were sending. By the early

1980s, interference was an issue in some frequency bands. The result has been a critical examination of the technologies needed to make higher frequencies available for both commercial and military applications.

These higher frequencies are known as *mm waves* — and, for convenience, are generally defined as the wavelengths from 10 mm to 1 mm (30 to 300 GHz). One of the obvious advantages of this new domain is the amount of spectrum space available: 270 GHz.

Among the advantages that mm systems offer are broad bandwidths (good for high speed data links), higher spatial resolution, less interference due to narrow antenna beams, and, at the high end of the range (near 300GHz), a favorable alternative to optical (infra-red) technologies.

Much work has already been done in this region, but the advent of computer modeling techniques is advancing the rate at which progress can be made. A major limitation on the use of mm waves has been the lack of appropriate devices, hardware, and test equipment. Within the past two years, however, there have been significant developments in each of these areas.

The generation and detection of mm waves requires the use of components and techniques that are unfamiliar to most Amateurs. Semiconductor devices are the only sources of RF power at frequencies above 30 GHz. In general, these devices take the form of negative resistance oscillators and

depend on the characteristics of special diodes. The more common of these diodes are GUNN diodes, named for the discoverer of transferred electron devices; IMPATTs (*Impact Ionization Avalanche Transit Time*); and TRAPATTs (*Trapped Plasma Avalanche Triggered Transit*).

Each of these devices has characteristics that make it best for certain applications. The tradeoffs are between frequency (of operation), power output, and noise. IMPATT diodes have been fabricated that can produce 1 watt at about 70 GHz.

Transistors will soon be available for the mm region. GaAs FETs are already being made as small signal amplifiers above 30 GHz, and it shouldn't be too long before HEMT (*High Electron Mobility*) and MESFET (*Metal on Oxide*) devices are available to 100 GHz or so. Power transistors for this region are still a few years off — but only a few. Other necessary components are being developed quite aggressively, as is test equipment. Hewlett Packard has just announced its first line of mm wave spectrum/network analyzers. Special materials and design techniques will be needed to take best advantage of the promise held by mm waves. Work is underway in each of these areas, and the results will not be more than four to five years away.

#### ham radio

**Next month:** Part II — Where Do We Go From Here?

**UNIVERSAL  
PACKET CONTROLLER  
model PK-80**



**\$219<sup>95</sup>** Suggested  
Amateur Net Price

The AEA model PK-80 is a wired, tested, and calibrated version of the famous TAPR TNC-2 and comes with a one-year conditional AEA warranty.

You can interface the PK-80 with any ASCII terminal or a personal computer and standard terminal software. The PK-80 is loaded with all the latest AX.25 version 2.0 software and advanced packet hardware circuitry that makes the TNC-2 the newest benchmark for comparison.

Compare the following as representative of the advanced new features relative to the competition.

- Hardware HDLC for full duplex
- True Data Carrier Detect (DCD) for HF operation
- Operates with 300, 1200, 2400, 4800, and 9600 baud terminals
- Five front-panel status indicators
- Multiple connect
- Connect check (poll final bit) fully implemented
- Connect AUTO response message
- Only three commands necessary for making standard contacts
- 82 software commands possible for the most demanding requirements

Prices and Specifications Subject to Change Without Notice or Obligation.

**ADVANCED ELECTRONICS APPLICATIONS, INC.**  
P.O. Box C-2160, Lynnwood, WA 98036-0918  
TELEX: 6972496 AEA INTL UW  
(206) 775-7373

**ADVERTISER'S INDEX AND READER SERVICE NUMBERS**

Listed below are the page number and reader service number for each company advertising in this issue. To get more information on their advertised products, use the bind-in card found elsewhere in this issue, select the correct reader service number from either the ad or this listing, check off the numbers, fill in your name and address, affix a postage stamp and return to us. We will promptly forward your request to the advertiser and your requested information should arrive shortly. If the card is missing, send all the pertinent information on a separate sheet of paper to: *ham radio magazine*, Attn: Reader Service, Greenville, NH 03048.

READER SERVICE #	PAGE #	READER SERVICE #	PAGE #
188	Advanced Computer Controls, Inc. .... 13	143	Kendecom/MCS ..... 24
187	Advanced Receiver Research ..... 100	*	Tri-Kenwood Communications ..... 2, 5, 7 Cover IV
183	AEA ..... 1	142	LaCue Communications ..... 8
184	AEA ..... 83	141	Larsen Electronics ..... 68
185	AEA ..... 110	140	Lewis Electronics ..... 64
186	AEA ..... 97	139	LUXOR (North America) Corp ..... 56, 5
182	All Electronics Corp ..... 50	136	Madison Electronics Supply ..... 71
181	Alpha Delta Communications ..... 75	137	Madison Electronics Supply ..... 3
*	Amateur Electronic Supply ..... 82	138	Madison Electronics Supply ..... 4
179	Amateur Wholesale Electronics ..... 23	135	Meadowlake Corp ..... 71
180	Amateur Wholesale Electronics ..... 81	146	John J. Meshna Jr., Inc ..... 7
178	Amertron ..... 63	134	MFJ Enterprises ..... 1
177	AMSAT ..... 34	133	Micro Systems Institute ..... 10
176	Antique Electronic Supply ..... 98	132	Microwave Filter, Inc ..... 4
175	ARRL ..... 83	131	Minds Eye Publications ..... 108
*	Barker & Williamson ..... 48	130	Missouri Radio Center ..... 5
*	Barry Electronics ..... 101	129	Nemal Electronics ..... 98
174	Bauman Sales ..... 63	*	NRI Schools ..... 2
173	Bilal Company ..... 60	128	Nuts & Volts ..... 9
172	Buckmaster Publishing ..... 97	127	Omega Concepts ..... 108
*	Butternut Electronics ..... 52	*	Orlando Hamcation ..... 9
*	Caddell Coil Corp ..... 52	126	P.C. Electronics ..... 10
171	CeCo Communications ..... 62	125	Pac Comm Packet Radio Systems, Inc ..... 4
170	CMC Communications ..... 52	124	Pacific Rim Communications ..... 7
169	CMC Communications, Inc ..... 34	*	Packeterm ..... 4
168	Coaxial Dynamics, Inc ..... 80	123	Processor Concepts ..... 10
167	Colorado Radio ..... 75	122	Propagation Publishing ..... 7
166	Communications Concepts, Inc ..... 38	107	The PX Shack ..... 3
165	Communications Specialists ..... 16	121	QSKY Publishing ..... 8
164	Connect Systems, Inc ..... 112	120	Radio Amateur Callbook ..... 10
163	Crowley Mfg. Co. .... 108	119	Radiosporting ..... 10
162	CTM ..... 60	118	Ramsey Electronics, Inc ..... 4
161	Current Development Corp ..... 102	117	RF Parts/Westcom Eng ..... 9
160	Current Development Corp ..... 84	116	Sarton Associates ..... 10
*	Dayton Hamvention ..... 111	*	Satman, Inc ..... 10
159	DCC Data Service, Inc ..... 100	115	Spec Com ..... 3
*	Dick Smith Electronics ..... 97	114	Spectrum International, Inc ..... 1
158	Digiflex ..... 80	113	Spi Ro Distributing ..... 8
157	Down East Microwave ..... 75	112	STV/OnSat Magazine ..... 10
156	DX'ers Magazine, Gus Browning, W4BPD ..... 98	111	Sultronic ..... 9
155	EEB ..... 38	189	Tel Com ..... 3
154	EGE ..... 108	105	TNT Radio Sales, Inc ..... 11
*	Engineering Consulting ..... 97	110	Transverters Unlimited ..... 10
*	Falcon Communications ..... 83	*	University Microfilms Int ..... 4
*	Fox Tango Corp ..... 63	104	Vanguard Labs ..... 10
*	Gem Quad ..... 37	106	The VHF Shop ..... 7
152	GLB Electronics ..... 34	103	W9INN Antennas ..... 9
151	H.L. Heaster, Inc ..... 98	109	Wacom ..... 4
150	Hall Electronics ..... 84	108	Webster Communications ..... 3
149	Ham Radio Outlet ..... 30, 31	102	Western Electronics ..... 6
*	Ham Radio's Bookstore ..... 19, 60, 84, 89, 96, 101, 102, 104	101	Yaesu Electronics Corp ..... Cover I
*	The Ham Station ..... 62		
*	Hamtronics, NY ..... 67		
*	Hamtronics, PA ..... 102		
148	Hamtronics, PA ..... 84		
190	Harrison Radio ..... 103		
147	ICOM America, Inc ..... Cover II		
145	Jun's Electronics ..... 89		
144	Kantronics ..... 37		

**PRODUCT REVIEW/NEW PRODUCT**

303	Heath Company ..... 10
305	Jensen Tools, Inc ..... 9
304	LUXOR (North America) Corp ..... 9
302	MFJ Enterprises ..... 9
301	Radio School ..... 10

\*Please contact this advertiser directly.

Limit 15 inquiries per request

Please use before March 31, 1986.

**AEA BRINGS YOU THE  
BREAKTHROUGH**



CALL TOLL FREE FOR QUOTES

# TNT

# RADIO SALES INC.

# 1-800-328-0250

1-612-535-5050

(IN MINNESOTA—COLLECT)

## EXPLOSION OF VALUES!

**ICOM** **KENWOOD**  
**KANTRONICS** **TELEX HY-GAIN**  
**MIRAGE** **HUSTLER**  
**AEA** **KLM**  
**SANTEC** **ROHN**  
**KDK** **MFJ**  
**NYE VIKING** **AMERITRON**  
**WELZ** **BENCHER**  
**LARSEN** **BUTTERNUT**

**CALL NOW!**  
**1-800-328-0250**  
 FOR ABSOLUTE  
**LOWEST PRICE BUSTERS!**

### INVENTORY REDUCTION PRICED TO GO!

We must make room for your trade-ins. Check now for lowest prices on previously owned bench-tested equipment!

### NEW! ICOM R7000 RCVR

Covers continuous 25 mhz to 2 ghz!  
99 memories—scans—etc., etc.  
Loaded with features Available November, 1985.

VISA/MASTER CARD  
FREE SHIPPING  
ON MOST RIGS FOR CASH!



S.A.S.E. FOR OUR  
"BENCH-TESTED"  
USED EQUIPMENT LISTING

MON-FRI 9 AM - 6 PM CENTRAL TIME  
SATURDAY 9 AM - 5 PM

4124 West Broadway, Robbinsdale, MN 55422 (Mpls./St. Paul)

105

- ★ TECHNICAL FORUMS
- ★ ARRL AND FCC FORUMS
- ★ GIANT 3-DAY FLEA MARKET  
Starting Noon Friday  
All Day Saturday and Sunday
- ★ LICENSE EXAMINATIONS
- ★ NEW PRODUCTS AND EXHIBITS
- ★ GRAND BANQUET
- ★ ALTERNATIVE ACTIVITIES
- ★ SPECIAL GROUP MEETINGS
- ★ YL FORUM
- ★ PERSONAL COMPUTER FORUM
- ★ CW PROFICIENCY AWARDS
- ★ AMATEUR OF YEAR AWARD
- ★ SPECIAL ACHIEVEMENT AWARDS

# DAYTON Hamvention®

## April 25, 26, 27, 1986

Hara Arena and Exhibition Center — Dayton, Ohio

Meet your amateur radio friends from all over the world at the internationally famous Dayton HAMVENTION.

Seating will be limited for Grand Banquet and Entertainment on Saturday evening so please make reservations early.

If you have registered within the last 3 years you will receive a brochure in January. If not, write Box 44, Dayton, OH 45401.

Nominations are requested for Radio Amateur of the Year and Special Achievement Awards. Nomination forms are available from Awards Chairman, Box 44, Dayton, OH 45401.

For motel rates and reservations write to Hamvention Housing, 1980 Kettering Tower, Dayton, OH 45423-1980. Housing information phone, (513) 223-2612.  
**NO RESERVATIONS WILL BE ACCEPTED BY TELEPHONE.**

All other inquiries write Box 44, Dayton, OH 45401 or phone (513) 433-7720.

ALL Flea Market spaces will be sold in advance ONLY. NO spaces sold at gate. Entrance for set-up available starting Wednesday. Special Flea Market telephone (513) 223-0923.

**Bring your family and enjoy a great weekend in Dayton.**

Sponsored by the Dayton Amateur Radio Association, Inc.

#### ADMISSION

\$8 in advance, \$10 at door.  
(Valid for all 3 days)

#### BANQUET

\$14 in advance, \$16 at door.

#### FLEA MARKET SPACE

\$20 in advance.  
(Valid for all 3 days)

Checks for advance registration to  
Dayton HAMVENTION  
Box 2205, Dayton, OH 45401

**Registration processing  
starts Jan. 1, 1986.**

(Admission tickets must be ordered  
with Flea Market spaces.)



## THINGS TO LOOK FOR (AND LOOK OUT FOR) IN A PHONE PATCH

- One year warranty.
- A patch should work with any radio. AM, FM, ACSB, relay switched or synthesized.
- Patch performance should not be dependent on the T/R speed of your radio.
- Your patch should sound just like your home phone.
- There should not be any sampling noises to distract you and rob important syllables. The best phone patches do not use the cheap sampling method. (Did you know that the competition uses VOX rather than sampling in their \$1000 commercial model?)
- A patch should disconnect automatically if the number dialed is busy.
- A patch should be flexible. You should be able to use it simplex, repeater aided simplex, or semi-duplex.
- A patch should allow you to manually connect any mobile or HT on your local repeater to the phone system for a fully automatic conversation. Someone may need to report an emergency!
- A patch should not become erratic when the mobile is noisy.
- You should be able to use a power amplifier on your base to extend range.
- You should be able to connect a patch to the MIC and EXT. speaker jack of your radio for a quick and effortless interface.
- You should be able to connect a patch to three points inside your radio (VOL high side, PTT, MIC) so that the patch does not interfere with the use of the radio and the VOL. and SQ. settings do not affect the patch.
- A patch should have MOV lightning protectors.
- Your patch should be made in the USA where consultation and factory service are immediately available. (Beware of an inferior offshore copy of our former PRIVATE PATCH II.)

**ONLY  
PRIVATE PATCH III  
GIVES YOU ALL  
OF THE ABOVE**

# PRIVATE PATCH III

## SIMPLEX SEMI-DUPLEX INTERCONNECT



**The telephone is the most powerful mode of communications . . . PRIVATE PATCH III gives you full use of your home telephone from your mobile and HT radios!**

With only three simple connections to your base station radio, PRIVATE PATCH III will give you more communications power per dollar than you ever imagined possible.

Suddenly the utility of your radio is drastically increased. There are new sounds . . . dial tones, ring tones, CW ID and the sound of voices you never expected to hear on your mobile or HT radio! What a convenience!

PRIVATE PATCH III frees you from memberships, cliques and other hassles common to many repeater autopatches. You can call who you want, when you want and for as long as you want. You can even receive your incoming calls!

**To Learn more about PRIVATE PATCH III and the advantages of the VOX concept, call or write for our four page brochure today!**

### PARTIAL LIST OF FEATURES

- OPERATES SIMPLEX, THROUGH REPEATERS, OR DUPLEX ON REPEATERS
- VOX BASED
- TOLL RESTRICT (Digit counting and programmable first digit lockout)
- SECRET CODE DISABLES TOLL RESTRICT FOR ONE TOLL CALL—Automatic re-arm
- AUTOMATIC BUSY SIGNAL DISCONNECT
- CONTROL INTERRUPT TIMER (Maintains positive mobile control)
- CW ID When you connect again
- THREE DIGIT ACCESS CODE (e.g. ★91)
- RINGOUT (Reverse patch) Ringout inhibit if channel busy
- RESETTABLE THREE MINUTE TIMER
- SPARE RELAY POSITION
- 115VAC SUPPLY

### DEALERS

Options:

FCC approved coupler  
12 VDC or 230 VAC power

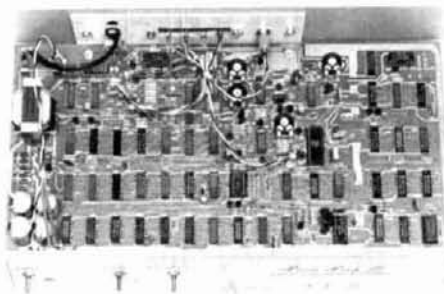

- |  |   |
|--|---|
| AMATEUR ELECTRONIC SUPPLY<br>Milwaukee WI, Wickliffe Oh,<br>Orlando FL, Clearwater FL,<br>Las Vegas NV | MADISON ELECTRONICS SUP<br>Houston, TX          |
| BARRY ELECTRONICS CORP.<br>New York, NY  | MIAMI RADIO CENTER CORP.<br>Miami FL            |
| COLES COMMUNICATIONS<br>San Antonio TX   | MIKES ELECTRONICS<br>Ft. Lauderdale, Miami FL   |
| EGE, INC.<br>Woodbridge, VA  | N&G DISTRIBUTING CORP.<br>Miami FL              |
| ERICKSON COMMUNICATIONS<br>Chicago IL  | PACE ENGINEERING<br>Tucson AZ                   |
| HAM RADIO OUTLET<br>Anaheim CA, Burlingame CA,<br>Oakland CA, Phoenix AZ,<br>San Diego CA, Van Nuys CA | THE HAM STATION<br>Evansville IN                |
| HENRY RADIO<br>Los Angeles CA  | TEXAS TOWERS<br>Piano, TX                       |
| INTERNATIONAL RADIO<br>SYSTEMS<br>Miami, FL  | TNT RADIO SALES<br>Robbinsdale, MN              |
| JUNS ELECTRONICS<br>Culver City CA   | WESTCOM<br>San Marcos, CA                       |
|  | CANADA:<br>DOLLARD ELECTRONICS<br>Vancouver, BC |
|  | SKYWAVE RADIO SYSTEMS, L<br>Burnaby, B.C.       |

**CONNECT  
SYSTEMS  
INCORPORATED**

(213) 373-6803

23731 Madison St., Torrance, CA 90501

## High power to get you out. Battery saver to keep you there.

Where other HTs don't make it, Yaesu's 2-meter FT-209RH and 440-MHz FT-709R keep going strong. Here's why:

Our 2-meter model offers you 5 watts output. And our 440-MHz model offers 4½ watts.

Yet there's no excessive battery drain, thanks to a unique user-programmable Power Saver. When activated, it puts the rig "to sleep" while monitoring, and "wakes it up" when the squelch breaks. Thus, you can listen for hours while keeping plenty of power in reserve.

And despite the wealth of advanced features, operation is actually simple and intuitive. That's why our radios are so much easier to "learn" than any other advanced HT.

At the push of a button, you can recall the information you've independently stored in each of the ten memories: receive frequency, standard or non-standard offset, even tone encode/decode.

Monitoring your favorite repeaters or simplex frequencies is just as easy. Just touch a button to scan all memory channels, selected ones, or all frequencies between adjacent memories. And use the priority feature to return automatically to a special frequency.

Bring up controlled-access machines with the optional plug-in subaudible tone encoder/decoder, independently programmed from the keyboard for each channel. Then use the decode function to listen for tone-encoded signals on selected channels—without a lot of chatter.

Finally, both HTs cover 10 MHz, and come complete with a 500-mAh battery, charger and soft case. Options include a VOX headset and hard leather case.

So next time you visit your dealer, pick up Yaesu's 2-meter FT-209RH or 440-MHz FT-709R. Because they not only get you out, they keep you there too.

# YAESU

*Our 30th Anniversary.*

#### Yaesu Electronics Corporation

6851 Walthall Way, Paramount, CA 90723  
(213) 633-4007

#### Yaesu Cincinnati Service Center

9070 Gold Park Drive, Hamilton, OH 45011  
(513) 874-3100

Prices and specifications subject to change without notice.

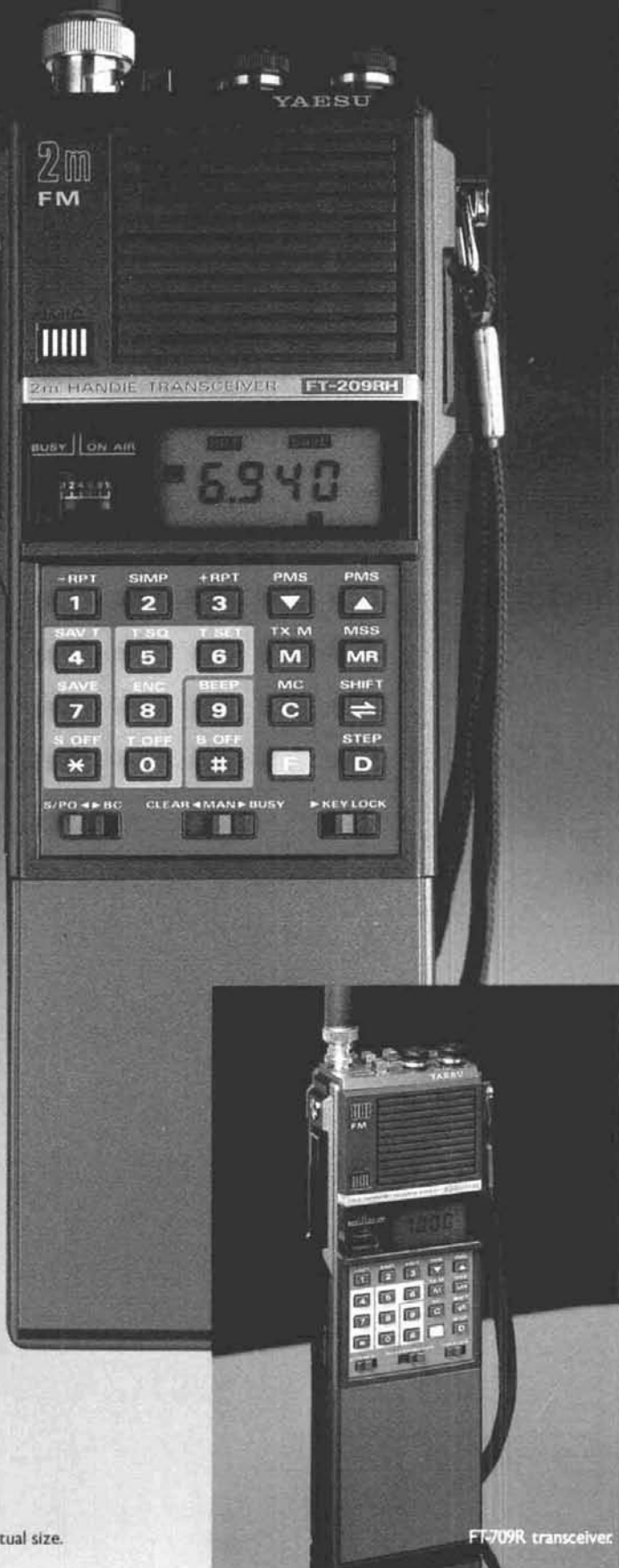

209RH shown actual size.

FT-709R transceiver

# KENWOOD

...pacesetter in Amateur radio

WAIT  
220 MHz  
Coming soon!

## Power-Full...70 Watts!

### TM-2570A/2550A/2530A

#### Sophisticated FM transceivers

**Kenwood sets the pace again!**

The all-new "25-Series" brings the industry's first compact 70-watt 2-meter FM mobile transceiver. There is even an *auto dialer* which stores 15 telephone numbers! There are three power versions to choose from: The TM-2570A 70-watt model, the TM-2550A for 45-watts, and the 25-watt TM-2530A.

- First 70-watt FM mobile (TM-2570A)
- First mobile transceiver with telephone number memory and auto-dialer (up to 15 telephone numbers)
- Direct keyboard entry of frequency
- Automatic repeater offset selection according to the ARRL 2-meter band plan — a **Kenwood exclusive!**
- Extended frequency coverage for MARS and CAP (142-149 MHz; 141-151 MHz modifiable)
- 23 channel memory for offset, frequency and sub-tone
- Big multi-color LCD and back-lit controls for excellent visibility

- Front panel programmable 38-tone CTCSS encoder **includes 97.4 Hz** (optional)
- 16-key DTMF pad, with audible monitor
- Center-stop tuning — **another Kenwood exclusive!**
- Frequency lock switch
- **New** 5-way adjustable mounting system
- **Unique** offset microphone connector — relieves stress on microphone cord

- HI/LOW Power switch (adjustable LOW power)
- Compact DIN size



#### Introducing... Digital Channel Link

Compatible with Kenwood's DCS (Digital Code Squelch), the DCL system enables your rig to **automatically** QSY to an open channel. Now you can automatically switch over to a simplex channel after repeater contact! Here's how it works:

The DCL system searches for an open channel, remembers it, returns to the original frequency and transmits control information to another DCL-equipped station that switches **both** radios to the open channel. Micro-processor control assures fast and reliable operation. The whole process happens in an instant!

Large heatsink with built-in cooling fan (TM-2570A)



BUILT-IN  
COOLING FAN  
(TM-2570A)

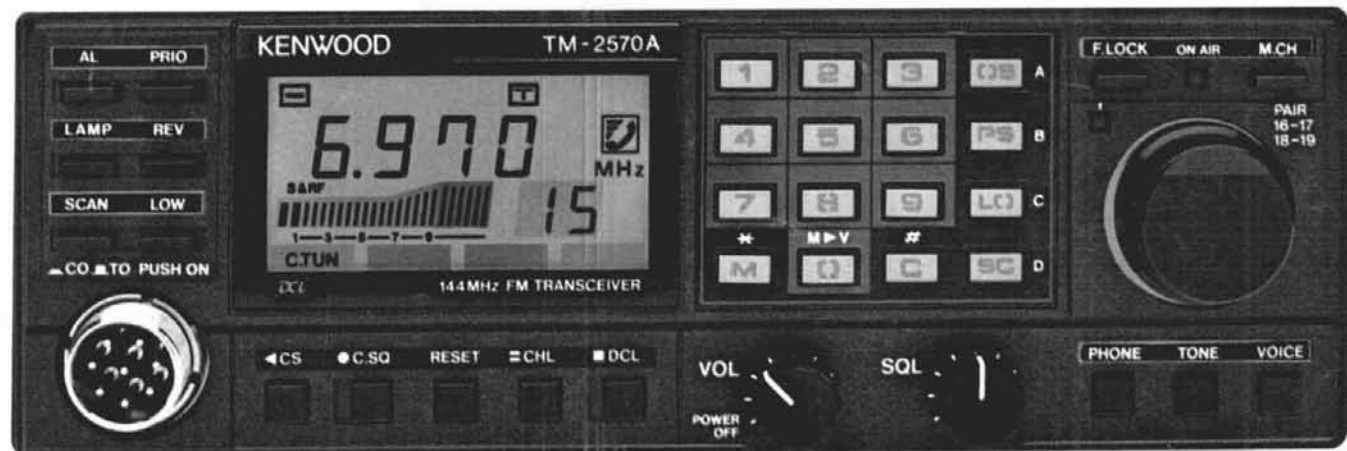

#### Optional Accessories

- TU-7 38-tone CTCSS encoder
- MU-1 DCL modem unit
- VS-1 voice synthesizer
- PG-2K extra DC cable
- PG-3A DC line noise filter
- MB-10 extra mobile bracket
- CD-10 call sign display
- PS-430 DC power supply for TM-2550A/2530A

- PS-50 DC power supply for TM-2570A
- MC-60A/MC-80/MC-85 desk mics.
- MC-48 extra DTMF mic. with UP/DWN switch
- MC-42S UP/DWN mic.
- MC-55 (8-pin) mobile mic. with time-out timer
- SP-40 compact mobile speaker
- SP-50 mobile speaker
- SW-200A/SW-200B SWR/power meters
- SW-100A/SW-100B compact SWR/power meters
- SWT-1 2m antenna tuner

Actual size front panel

# KENWOOD

TRIO-KENWOOD COMMUNICATIONS  
1111 West Walnut Street  
Compton, California 90220

Complete service manuals are available for all Trio Kenwood transceivers and most accessories. Specifications and prices are subject to change without notice or obligation.